

Vision Sensor FH Series Vision System

Hardware Setup Manual

FH-1□□□/FH-1□□□-□□
FH-2□□□/FH-2□□□-□□
FH-3□□□/FH-3□□□-□□
FH-5□□□/FH-5□□□-□□
FH-L□□□/FH-L□□□-□□



NOTE

- All rights reserved.
- No part of this publication may be reproduced, stored in a retrieval system, or transmitted, in any form, or by any means, mechanical, electronic, photocopying, recording, or otherwise, without the prior written permission of OMRON.
- No patent liability is assumed with respect to the use of the information contained herein. Moreover, because OMRON is constantly striving to improve its high-quality products, the information contained in this manual is subject to change without notice. Every precaution has been taken in the preparation of this manual. Nevertheless, OMRON assumes no responsibility for errors or omissions.

Neither is any liability assumed for damages resulting from the use of the information contained in this publication.

Trademarks

- Sysmac and SYSMAC are trademarks or registered trademarks of OMRON Corporation in Japan and other countries for OMRON factory automation products.
- This software is based in part on the work of the Independent JPEG Group.
- Microsoft, Windows, Windows Vista, Excel, and Visual Basic are either registered trademarks or trademarks of Microsoft Corporation in the United States and other countries.
- Intel, Core and Pentium are trademarks of Intel Corporation in the U.S. and/or other countries.
- EtherCAT® is registered trademark and patented technology, licensed by Beckhoff Automation GmbH, Germany.
- ODVA, CIP, CompoNet, DeviceNet, and EtherNet/IP are trademarks of ODVA.
- The SD, SDHC, microSD, and microSDHC logos are trademarks of SD-3C, LLC.



- QR Code is a registered trademark of DENSO WAVE INCORPORATED.
- MELSEC is a registered trademarks of Mitsubishi Electric Corporation.

Other company names and product names in this document are the trademarks or registered trademarks of their respective companies.

Copyrights

Microsoft product screen shots reprinted with permission from Microsoft Corporation.

Introduction

Thank you for purchasing the FH Series.

This manual contains information that is necessary to use the FH Series.

Please read this manual and make sure you understand the functionality and performance of the FH Series before you attempt to use it in a control system.

Keep this manual in a safe place where it will be available for reference during operation.

Intended Audience

This manual is intended for the following personnel, who must also have knowledge of electrical systems (an electrical engineer or the equivalent).

- Personnel in charge of introducing FA systems.
- Personnel in charge of designing FA systems.
- Personnel in charge of installing and maintaining FA systems.
- Personnel in charge of managing FA systems and facilities.

Applicable Products

This manual covers the following products.

- FH-1□□□
- FH-1□□□-□□
- FH-2□□□
- FH-2□□□-□□
- FH-3□□□
- FH-3□□□-□□
- FH-5□□□
- FH-5□□□-□□
- FH-L□□□
- FH-L□□□-□□

Part of the specifications and restrictions are given in other manuals. Refer to *Relevant Manuals* on *Relevant Manuals* on page 2 and *Related Manuals* on page 25.

Relevant Manuals

The following table provides the relevant manuals for the FH Series.

Read all of the manuals that are relevant to your system configuration and application before you use the FH Series.

Purpose of use	Manual							
	Basic information			FH Series Smart Camera Setup Manual	FH/FHV Series Vision System Processing Item Function Reference Manual	FH Series Vision System Macro Customize Functions Programming Manual	FH Series Vision System User's Manual for Communications Settings	FH Series Vision System Operation Manual for System Studio
	FH/FHV Series Vision System User's Manual	FH Series Vision System Hardware Setup Manual						
Overview of FH series	●	●						
Setup and Wiring								
EtherCAT								
EtherNet/IP								
PROFINET		●	●					
Ethernet								
RS-232C								
Parallel interface								
Setup the communication setting of Sensor Controller								●
EtherCAT								
EtherNet/IP								
PROFINET	●	●	●			●		
Ethernet								
RS-232C								
Parallel interface								
Setup the Sensor Controller								●
EtherCAT								
EtherNet/IP								
PROFINET	●					●		
Ethernet								
RS-232C								
Parallel interface								

Purpose of use	Manual						
	Basic information			FH/FHV Series Vision System Processing Item Function Reference Manual	FH Series Vision System Macro Customize Functions Programming Manual	FH/FHV Series Vision System User's Manual for Communications Settings	FH Series Vision System Operation Manual for Sysmac Studio
	FH/FHV Series Vision System User's Manual	FH Series Vision System Hardware Setup Manual	FHV Series Smart Camera Setup Manual				
Create and Set the Scene							•
EtherCAT							
EtherNet/IP							
PROFINET	•			•			
Ethernet							
RS-232C							
Parallel interface							
Optimizing the Scene Flow							
EtherCAT							
EtherNet/IP							
PROFINET				•	•		
Ethernet							
RS-232C							
Parallel interface							
Connecting the Controller							•
EtherCAT							
EtherNet/IP							
PROFINET	•	•	•			•	
Ethernet							
RS-232C							
Parallel interface							
Using Helpful Functions							•
EtherCAT							
EtherNet/IP							
PROFINET	•						
Ethernet							
RS-232C							
Parallel interface							
Troubleshooting and Problem Solving	•						

Manual Structure

Page Structure

The following page structure is used in this manual.

The diagram illustrates the structure of a manual page. It shows a page with a grey header bar containing the text "4 Installation and Wiring". Below the header is a section titled "4-3 Mounting Units". Underneath this is a sub-section titled "4-3-1 Connecting Controller Components". The main body of the page contains a numbered list of steps: "1 Join the Units so that the connectors fit exactly." followed by a diagram of units with labels "Hook", "Connector", and "Hook holes". Step "2" is "The yellow sliders at the top and bottom of each Unit lock the Units together. Move the sliders toward the back of the Units as shown below until they click into place." This is followed by another diagram showing sliders being moved, with labels "Release", "Lock", and "Slider". Below the diagrams is a "Precautions for Correct Use" section with a warning icon and text: "The sliders on the tops and bottoms of the Power Supply Unit, CPU Unit, I/O Units, Special I/O Units, and CPU Bus Units must be completely locked (until they click into place) after connecting the adjacent Unit connectors." At the bottom of the page, there is a footer with "NJ-series CPU Unit Hardware User's Manual (W500)" on the left and "4-9" on the right. Annotations on the right side of the diagram identify these elements as Level 1 heading, Level 2 heading, Level 3 heading, a page tab, and special information. Annotations on the left side identify the Level 2 heading, Level 3 heading, a step in a procedure, special information, and manual name.

Level 1 heading

Level 2 heading

Level 3 heading

Gives the current headings.

Page tab

Gives the number of the main section.

Level 2 heading

Level 3 heading

A step in a procedure

Indicates a procedure.

Special information

Icons indicate precautions, additional information, or reference information.

Manual name

Note This illustration is provided only as a sample. It may not literally appear in this manual.

Special Information

Special information in this manual is classified as follows:



Precautions for Safe Use

Precautions on what to do and what not to do to ensure safe usage of the product.



Precautions for Correct Use

Precautions on what to do and what not to do to ensure proper operation and performance.



Additional Information

Additional information to read as required.

This information is provided to increase understanding or make operation easier.

CONTENTS

Introduction	1
Intended Audience	1
Applicable Products	1
Relevant Manuals.....	2
Manual Structure.....	4
Page Structure	4
Special Information	5
Terms and Conditions Agreement.....	11
Warranty, Limitations of Liability	11
Application Considerations	12
Disclaimers	12
Safety Precautions.....	14
Symbols and the Meanings for Safety Precautions Described in This Manual	14
Meanings of Alert Symbols	14
Warning.....	15
Precautions for Safe Use	16
Condition of the Fitness of OMRON Products	16
Installation Environment	16
Power Supply and Wiring	17
Grounding	17
Others	17
Precautions for Correct Use	19
Installation and Storage Sites (FH-1000/2000/3000/5000 series)	19
Installation and Storage Sites (FH-L series)	19
Orientation of Product.....	19
Ambient Temperature	19
Noise Resistance.....	20
Component Installation and Handling.....	20
Maintenance	20
Communications with Upper Device	20
Failsafe Measures	21
Connecting the Sensor Controller and Monitor with a Switcher and Splitter	21
Regulations and Standards	22
All Series.....	22
FH-1000/2000/3000/5000 series	22
FH-L series	23
Related Manuals.....	25
Terminology.....	26
Revision History.....	31
Sections in This Manual	33

Section 1 Confirm the Package

1-1	Sensor Controller.....	1 - 2
1-1-1	FH-1□□□/ FH-2□□□/ FH-3□□□/ FH-5□□□ Series.....	1 - 2
1-1-2	FH-1□□□-10/ FH-2□□□-10/ FH-3□□□-10/ FH-5□□□-10 Series.....	1 - 2
1-1-3	FH-1□□□-20/ FH-2□□□-20/ FH-3□□□-20/ FH-5□□□-20 Series.....	1 - 3
1-1-4	FH-L□□□ Series	1 - 3
1-1-5	FH-L□□□-10 Series	1 - 3
1-2	Sold Separately	1 - 5
1-2-1	Cameras and Related	1 - 5
1-2-2	Monitor	1 - 7
1-2-3	Lighting and Lighting Controller	1 - 8
1-2-4	Accessories.....	1 - 9
1-2-5	Cable.....	1 - 10
1-2-6	Software.....	1 - 12

Section 2 Overview of FH series

2-1	Overview of System.....	2 - 2
2-1-1	Basic System of Measurement	2 - 2
2-1-2	FH-1000/ FH-2000/ FH-3000/ FH-5000 Series	2 - 4
2-1-3	FH-L Series	2 - 5
2-2	System Configuration.....	2 - 6
2-2-1	FH-1000/2000/3000/5000 Series	2 - 6
2-2-2	FH-L Series	2 - 7
2-3	Flow of Use Procedure	2 - 8

Section 3 Configuration

3-1	Sensor Controller.....	3 - 3
3-1-1	FH-1000/2000/3000/5000 Series	3 - 3
3-1-2	FH-L Series	3 - 14
3-2	Camera.....	3 - 19
3-2-1	High-speed digital CMOS Camera (FH-S camera series)	3 - 19
3-2-2	Digital CMOS Camera.....	3 - 24
3-2-3	Digital CCD Camera: FZ-S Camera Series.....	3 - 27
3-2-4	High-speed Digital CCD Camera: FZ-SH Camera Series.....	3 - 29
3-2-5	Small Digital CCD Cameras: FZ-S Camera Series.....	3 - 30
3-2-6	Intelligent Compact Digital CMOS Camera: FZ-S camera Series.....	3 - 33
3-3	Camera Cable	3 - 36
3-3-1	Camera Cable and Right-angle Camera Cable	3 - 36
3-3-2	Bend resistant Camera Cable and Bend resistant Right-angle Camera Cable	3 - 37
3-3-3	Long-distance Camera Cable and Long-distance Right-angle Camera Cable	3 - 38
3-3-4	Cable Connection Table	3 - 39
3-3-5	Cable Extension Units.....	3 - 43
3-4	Lens.....	3 - 47
3-4-1	C-mount Lens for 1/3-inch Image Sensor (SV-V Series)	3 - 47
3-4-2	C-mount Lens for 2/3-inch Image Sensor (SV-H Series)	3 - 48
3-4-3	C-mount Lens for 1-inch Image Sensor (VS-H1 Series)	3 - 49
3-4-4	C-mount Lens for 4/3-inch Image Sensor (VS-LLD Series).....	3 - 50
3-4-5	M42-mount Lens for Large Image Sensor (VS-L/M42-10 Series).....	3 - 51
3-4-6	Lenses for Small Camera (FZ-LES Series).....	3 - 51
3-4-7	Vibration and Shock Resistant C-mount Lens for 2/3-inch Image Sensor (VS-MCA Series).....	3 - 52
3-4-8	Vibration and Shock Resistant C-mount Lens for 1-inch Image Sensor (VS-MCH Series)	3 - 54
3-4-9	Vibration and Shock Resistant C-mount Lens for 1-inch Image Sensor (VS-MCH1 Series)	3 - 57
3-4-10	Vibration and Shock Resistant M42-mount Lens for 1.8-inch Image Sensor (VS-MCL/ M42-10 Series).....	3 - 60

3-4-11	High-resolution Telecentric Lens for C-mount Lens for 2/3-inch Image Sensor (VS-TCH Series)	3 - 62
3-4-12	High-resolution Telecentric Lens for C-mount Lens for 1.1-inch Image Sensor (VS-TEV Series).....	3 - 64
3-4-13	Extension Tubes.....	3 - 65
3-4-14	Meaning of Optical Chart	3 - 66
3-5	Touch Panel Monitor and Cable	3 - 82
3-6	LCD and Cable	3 - 88
3-7	Sysmac Studio	3 - 91

Section 4 Handling and Installation Environment

4-1	All Series.....	4 - 2
4-2	FH-1000/2000/3000 Series	4 - 4
4-3	FH-L Series	4 - 5

Section 5 Setup and Wiring

5-1	When turning ON and OFF.....	5 - 2
5-1-1	All Series	5 - 2
5-1-2	FH-1000/2000/3000/5000 Series	5 - 3
5-1-3	FH-L Series	5 - 3
5-2	Fail-Safe Measures	5 - 4
5-3	Sensor Controller Installation.....	5 - 5
5-3-1	All Series	5 - 5
5-3-2	FH-1000/2000/3000/5000 Series	5 - 5
5-3-3	FH-L Series	5 - 11
5-4	Setup Touch Panel Monitor or Monitor.....	5 - 20
5-4-1	All Series	5 - 20
5-4-2	FH-1000/2000/3000/5000 Series	5 - 20
5-4-3	FH-L Series	5 - 20
5-5	Camera Installation.....	5 - 22
5-5-1	All Series	5 - 22
5-5-2	FH-1000/2000/3000/5000 Series	5 - 23
5-5-3	FH-L Series	5 - 24
5-6	Insert/Remove SD Memory Card or USB memory	5 - 25
5-6-1	Common in all series.....	5 - 25
5-7	Use by Connecting Software	5 - 26
5-7-1	Sysmac Studio FH Tool.....	5 - 26
5-7-2	FZ_FH Remote Operation Tool	5 - 26
5-7-3	Simulation Software	5 - 26
5-8	Installation in a Control Panel	5 - 27
5-8-1	All Series	5 - 27
5-8-2	FH-1000/2000/3000/5000 Series	5 - 29
5-8-3	FH-L Series	5 - 31

Section 6 I/O Interface

6-1	Parallel Interface	6 - 2
6-1-1	All Series	6 - 2
6-1-2	FH-1000/2000/3000/5000 Series	6 - 3
6-1-3	FH-L Series	6 - 12
6-1-4	Other (Parallel Converter Cable).....	6 - 18

6-2	Encoder Interface	6 - 29
6-2-1	FH-1000/2000/3000/5000 Series	6 - 29
6-3	EtherCAT Interface	6 - 32
6-3-1	FH-1000/2000/3000/5000 Series	6 - 32
6-4	Ethernet Interface	6 - 34
6-4-1	FH-1000/2000/3000/5000 Series	6 - 34
6-4-2	FH-L Series	6 - 36
6-5	Serial Interface	6 - 38
6-5-1	All Series	6 - 38

Index

Terms and Conditions Agreement

Warranty, Limitations of Liability

Warranties

- **Exclusive Warranty**

Omron's exclusive warranty is that the Products will be free from defects in materials and workmanship for a period of twelve months from the date of sale by Omron (or such other period expressed in writing by Omron). Omron disclaims all other warranties, express or implied.

- **Limitations**

OMRON MAKES NO WARRANTY OR REPRESENTATION, EXPRESS OR IMPLIED, ABOUT NON-INFRINGEMENT, MERCHANTABILITY OR FITNESS FOR A PARTICULAR PURPOSE OF THE PRODUCTS. BUYER ACKNOWLEDGES THAT IT ALONE HAS DETERMINED THAT THE PRODUCTS WILL SUITABLY MEET THE REQUIREMENTS OF THEIR INTENDED USE.

Omron further disclaims all warranties and responsibility of any type for claims or expenses based on infringement by the Products or otherwise of any intellectual property right.

- **Buyer Remedy**

Omron's sole obligation hereunder shall be, at Omron's election, to (i) replace (in the form originally shipped with Buyer responsible for labor charges for removal or replacement thereof) the non-complying Product, (ii) repair the non-complying Product, or (iii) repay or credit Buyer an amount equal to the purchase price of the non-complying Product; provided that in no event shall Omron be responsible for warranty, repair, indemnity or any other claims or expenses regarding the Products unless Omron's analysis confirms that the Products were properly handled, stored, installed and maintained and not subject to contamination, abuse, misuse or inappropriate modification. Return of any Products by Buyer must be approved in writing by Omron before shipment. Omron Companies shall not be liable for the suitability or unsuitability or the results from the use of Products in combination with any electrical or electronic components, circuits, system assemblies or any other materials or substances or environments. Any advice, recommendations or information given orally or in writing, are not to be construed as an amendment or addition to the above warranty.

See <http://www.omron.com/global/> or contact your Omron representative for published information.

Limitation on Liability; Etc

OMRON COMPANIES SHALL NOT BE LIABLE FOR SPECIAL, INDIRECT, INCIDENTAL, OR CONSEQUENTIAL DAMAGES, LOSS OF PROFITS OR PRODUCTION OR COMMERCIAL LOSS IN ANY

WAY CONNECTED WITH THE PRODUCTS, WHETHER SUCH CLAIM IS BASED IN CONTRACT, WARRANTY, NEGLIGENCE OR STRICT LIABILITY.

Further, in no event shall liability of Omron Companies exceed the individual price of the Product on which liability is asserted.

Application Considerations

Suitability of Use

Omron Companies shall not be responsible for conformity with any standards, codes or regulations which apply to the combination of the Product in the Buyer's application or use of the Product. At Buyer's request, Omron will provide applicable third party certification documents identifying ratings and limitations of use which apply to the Product. This information by itself is not sufficient for a complete determination of the suitability of the Product in combination with the end product, machine, system, or other application or use. Buyer shall be solely responsible for determining appropriateness of the particular Product with respect to Buyer's application, product or system. Buyer shall take application responsibility in all cases.

NEVER USE THE PRODUCT FOR AN APPLICATION INVOLVING SERIOUS RISK TO LIFE OR PROPERTY OR IN LARGE QUANTITIES WITHOUT ENSURING THAT THE SYSTEM AS A WHOLE HAS BEEN DESIGNED TO ADDRESS THE RISKS, AND THAT THE OMRON PRODUCT(S) IS PROPERLY RATED AND INSTALLED FOR THE INTENDED USE WITHIN THE OVERALL EQUIPMENT OR SYSTEM.

Programmable Products

Omron Companies shall not be responsible for the user's programming of a programmable Product, or any consequence thereof.

Disclaimers

Performance Data

Data presented in Omron Company websites, catalogs and other materials is provided as a guide for the user in determining suitability and does not constitute a warranty. It may represent the result of Omron's test conditions, and the user must correlate it to actual application requirements. Actual performance is subject to the Omron's Warranty and Limitations of Liability.

Change in Specifications

Product specifications and accessories may be changed at any time based on improvements and other reasons. It is our practice to change part numbers when published ratings or features are changed, or when significant construction changes are made. However, some specifications of the Product may

be changed without any notice. When in doubt, special part numbers may be assigned to fix or establish key specifications for your application. Please consult with your Omron's representative at any time to confirm actual specifications of purchased Product.

Errors and Omissions



Information presented by Omron Companies has been checked and is believed to be accurate; however, no responsibility is assumed for clerical, typographical or proofreading errors or omissions.

Safety Precautions







Symbols and the Meanings for Safety Precautions Described in This Manual

The following notation is used in this manual to provide precautions required to ensure safe usage of a Sensor Controller. The safety precautions that are provided are extremely important to safety. Always read and heed the information provided in all safety precautions.

The following notation is used.

 WARNING	<p>Indicates a potentially hazardous situation which, if not avoided, will result in minor or moderate injury, or may result in serious injury or death. Additionally there may be significant property damage.</p>
 Caution	<p>Indicates a potentially hazardous situation which, if not avoided, may result in minor or moderate injury or in property damage.</p>

Meanings of Alert Symbols

	<p>General Prohibition Indicates general prohibitions, including warnings, for which there is no specific symbol</p>
	<p>General Caution Indicates general cautions, including warnings, for which there is no specific symbol.</p>
	<p>Electrical Hazard Indicates the possible danger of electric shock under specific conditions.</p>
	<p>Explosion Hazard Indicates the possible danger of explosion under specific conditions.</p>
	<p>LED light Hazard Indicates the possible danger of LED radiation or light.</p>
	<p>High Temperature Caution Indicates the possible danger of injury by high temperature under specific conditions.</p>

Warning** WARNING**

This product must be used according to this manual and Instruction Sheet. Failure to observe this may result in the impairment of functions and performance of the product.



This product is not designed or rated for ensuring the safety of persons. Do not use it for such purposes.



Never connect the AC power supply with this product. When the AC power supply is connected, it causes the electric shock and a fire.



A lithium battery is built into the Controller and may occasionally combust, explode, or burn if not treated properly. Dispose of the Controller as industrial waste, and never disassemble, apply pressure that would deform, heat to 100°C or higher, or incinerate the Controller.



If you keep watching the LED light, it may have an adverse effect on the eyes, do not stare directly into the light emitted from the LED. If a specular object is used, take care not to allow reflected light to enter your eyes.



Do not touch the terminals while the power supply is ON. Doing so may result in electrical shock.



Please take external safety measures so that the system as a whole should be on the safe side even if a failure of a Sensor Controller or an error due to an external factor occurred. An abnormal operation may result in serious accident.



Please take fail-safe measures on your side in preparation for an abnormal signal due to signal conductor disconnection and/or momentary power interruption. An abnormal operation may result in a serious accident.

** Caution**

Please take fail-safe measures on your side in preparation for an abnormal signal due to signal conductor disconnection and/or momentary power interruption. An abnormal operation may result in a serious accident.



Precautions for Safe Use

Condition of the Fitness of OMRON Products

- Please do not use this product to directly or indirectly use to detect the human body for the purpose of ensuring the safety. In the same application, please use the safety sensor that is published on our sensor catalog.
- *Omron products* are designed and manufactured as general-purpose products for use in general industrial applications. They are not intended to be used in the following critical applications. If you are using *Omron products* in the following applications, *Omron* shall not provide any warranty for such *Omron products*, unless otherwise specifically agreed or unless the specific applications are intended by Omron.
 - a) Applications with stringent safety requirements, including but not limited to nuclear power control equipment, combustion equipment, aerospace equipment, railway equipment, elevator/lift equipment, amusement park equipment, medical equipment, safety devices and other applications that could cause danger/harm to people's body and life.
 - b) Applications that require high reliability, including but not limited to supply systems for gas, water and electricity, etc., 24 hour continuous operating systems, financial settlement systems and other applications that handle rights and property.
 - c) Applications under severe condition or in severe environment, including but not limited to outdoor equipment, equipment exposed to chemical contamination, equipment exposed to electromagnetic interference and equipment exposed to vibration and shocks.
 - d) Applications under conditions and environment not described in specifications.
- (1) In addition to the applications listed from (a) to (d) above, *Omron products* (see definition) are not intended for use in vehicles designed human transport (including two wheel vehicles). Please do NOT use Omron products for vehicles designed human transport. Please contact the Omron sales staff for information on our automotive line of products.
- (2) The above is part of the Terms and Conditions Agreement. Please use carefully read the contents of the guarantee and disclaimers described in our latest version of the catalog, data sheets and manuals.

Installation Environment

- Do not use the product in the environment with flammable or explosive gases.
- Install the product so that the air can flow freely through its cooling vents.
- Regularly clean the vent holes or fan outlet to prevent dust or particles blocking them. Internal temperature increases when those are blocked, it causes malfunction.
- To secure safety for operation and maintenance, install the product apart from high-voltage devices and power devices.
- Make sure to tighten all screws in mounting.
- When mounting the product using DIN rail mounting brackets, be sure to tighten all screws.
- Make sure to mount the product on DIN-rail securely.

Power Supply and Wiring

- Make sure to use the product within the power voltage specified by catalog, this manual, or instruction sheet.
- Never connect the product to AC power. If connected, it causes malfunction.
- Select and use the appropriate wire size based on consumption current.
- Keep the power supply wires as short as possible.
- Provide the power from a DC power supply (safety extra-low voltage circuits) that has been taken measures not to generate high-voltage.
- Check the following again before turning on the power.
 - Is the voltage and polarity of the power supply correct? (24 VDC)
 - Is not the load of the output signal short-circuited?
 - Is the load current of the output signal appropriate?
 - Is not the mistake found in wiring?
 - Is the voltage and polarity of the encoder power (ENC0_VDD/GND ENC1_VDD/GND) supply? (5VDC)
- The recommended power supply for FH-L series is the S8VS-□□□24 (manufactured by OMRON) or S8VK-G-□□□24 (manufactured by OMRON).

Grounding

- Since the power supply circuit for the Sensor Controller is described in the manual and instruction sheet, please check it.
- When a base is packed in a camera that will be connected to the Sensor Controller, make sure to mount the camera using the base. Since the enclosure of the camera body is connected to the internal circuits, the circuits may cause short-circuit with FG if the base is not used to mount the camera and result in malfunction or damage.
- Apply Class D grounding (grounding resistance: 100 [Ω] or less) Wire the grounding wire for the Sensor Controller independently. If the grounding wire is shared with other devices or connected to a building beam, the Sensor Controller may be adversely affected.
- Check the wiring again before turning on the power.
- Do not ground the plus (+) terminal when the FH series Sensor Controller is connected to the FH-SC12/FH-SM12. The internal circuits may cause a short-circuit and result in malfunction.
- Do not ground the plus (+) terminal of the 24 VDC power source when the FH series Sensor Controller is connected to the FH-MT12 with a USB cable. The internal circuits may cause a short-circuit and result in malfunction.
- When using the Sensor Controller and the peripheral devices such as a monitor, USB connection devices, RS-232C connection devices, there should be no potential difference in ground level. If not, it may cause malfunction. Take measures that the potential difference does not occur between the grounds for the Sensor Controller and the peripheral devices.

Others

- Use only the camera and cables designed specifically for the product. Use of other products may result in malfunction or damage of the product.
- Always turn OFF the power of the Sensor Controller and peripheral devices before connecting or disconnecting a camera or cable. Connecting the cable with power supplied may result in damage of the camera or peripheral devices.

- For the cable that is flexed repeatedly, use the robotic cable type (Bend resistant camera cable) to prevent damages.
- Do not apply torsion stress to the cable. It may damage the cable.
- Secure the minimum bending radius of the cable. Otherwise the cable may be damaged.
- Do not apply stress to the connector by pulling or bending the cable. It may damage the connector.
- Do not attempt to dismantle, repair, or modify the product.
- Should you notice any abnormalities, immediately stop use, turn OFF the power supply, and contact your OMRON representative.
- While the power is ON or immediately after the power is turned OFF, the Sensor Controller and camera case are still hot. Do not touch the case.
- When disposing of the product, treat it as an industrial waste.
- Do not drop the product nor apply excessive vibration or shock to the product. Doing so may cause malfunction or burning.
- This product is heavy. Be careful not to drop it while handling.
- A lithium battery is incorporated, so a severe injury may rarely occur due to ignition or explosion.
- Be sure to take fail-safe measures externally when controlling stages and robots by using the measurement results of the Sensor Controller (axis movement output by calibration and alignment measurement).

Precautions for Correct Use

Installation and Storage Sites (FH-1000/2000/3000/5000 series)

Install and store the product in a location that meets the following conditions:

- Surrounding temperature of 0 to +50°C*1 (-20 to +65°C in storage)
*1. FH-5000 Series: Surrounding temperature of 0 to 45°C
- No rapid changes in temperature (place where dew does not form)
- Relative humidity of between 35 to 85%
- No presence of corrosive or flammable gases
- Place free of dust, salts and iron particles
- Place free of vibration and shock
- Place out of direct sunlight
- Place where it will not come into contact with water, oils or chemicals
- Place not affected by strong electro-magnetic waves
- Place not near to high-voltage, or high-power equipment

Installation and Storage Sites (FH-L series)

Install and store the product in a location that meets the following conditions:

- Surrounding temperature of 0 to +55°C (-25 to +70°C in storage)
- No rapid changes in temperature (place where dew does not form)
- Relative humidity of between 10 to 90%
- No presence of corrosive or flammable gases
- Place free of dust, salts and iron particles
- Place free of vibration and shock
- Place out of direct sunlight
- Place where it will not come into contact with water, oils or chemicals
- Place not affected by strong electro-magnetic waves
- Place not near to high-voltage, or high-power equipment

Orientation of Product

- For efficient heat dissipation, install the product only with the orientation written in this manual or the Instruction Sheet. Install the product so that the air can flow freely through its cooling vents.

Ambient Temperature

- To secure good ventilation, install the product with clearance written in this manual or the Instruction Sheet.
- Do not install the product immediately above significant heat sources, such as heaters, transformers, or large-capacity resistors.
- Use the product within the operating temperature range based on the specifications of it.
- Install a forced cooling fan or air conditioner not to exceed the operating temperature range when the ambient temperature is close to the upper limit of its range.

Noise Resistance

- Do not install the Sensor Controller in a cabinet with high-voltage equipment installed.
- Mount the Sensor Controller at 200 [mm] or more from power cables apart.

Component Installation and Handling

- Touching Signal Lines:
When touching a terminal part or a signal wire in a connector, take anti-static measures using a wrist strap or another device to prevent damage from static electricity.
- Handling a USB Memory/SD memory card: (Refer to *Using External Storage Device* in the *Vision System FH/FHV Series User's Manual (Cat. No. Z365)*.
Do not insert an SD memory card in the reverse orientation, at an angle, or in a twisting manner. Before removing a USB memory device, make sure that data is not being read or written to them. Before removing a SD memory card, make sure that data is not being read or written to them. For a USB memory device, the memory device's LED flashes or lights while data is being read or written, so make sure that it is turned OFF before removing the memory. For SD memory card, the SD BUSY LED flashes or lights while data is being read or written, so make sure that it is turned OFF before removing the memory.
- Turning OFF the Power:
When a message is displayed indicating that a task is in progress, do not turn OFF the power. Doing so causes the data in the memory to be corrupted, resulting in the product not operating properly upon the next start-up.
Do not turn OFF during saving data to Sensor Controller.
When turns OFF, conform the followings proceedings have completed. and then operate again.
- When saves using Sensor Controller: Confirm the save processing is completed and next operation is possible.
- When saves using communication command: Intended command is completed. BUSY signal is turned OFF.
- Setting of Power Source:
The power source need to be supplied from DC power source apparatus which is taken a save ultra-low voltage circuit: to protect high voltage.

Maintenance

- Turn OFF the power and ensure the safety before maintenance.
- Clean the lens with a lens-cleaning cloth or air brush.
- Lightly wipe off dirt with a soft cloth.
- Dirt on the image element must be removed using an air brush.
- Do not use thinners or benzine.
- To secure safety for operation and maintenance, install the product apart from high-voltage devices and power devices.

Communications with Upper Device

- After confirming that the product is started up, communicate with the high-order device. Since uncertain signals may be output from the high-order interface at the product start-up, take measures such as clearing the reception buffer of your device at the initial stage.

Failsafe Measures

- Be sure to take fail-safe measures externally when controlling stages and robots by using the measurement results of the Sensor Controller (axis movement output by calibration and alignment measurement).
- On a Sensor Controller side, supplementary use operations and branches of the Sensor Controller to configure a check flow such as “data should not be externally provide if the data is in a range from -XXXXX to XXXXX” based on the stage/robots range of movement.

Connecting the Sensor Controller and Monitor with a Switcher and Splitter

- Do not use devices that may require re-recognition of the monitor by the Sensor Controller when a switching operation was performed. If such re-recognition processing happens at switching operation, it may cause measurement time to be longer.

Regulations and Standards

All Series

Using Product Outside Japan

If you export (or provide a non-resident with) this product or a part of this product that falls under the category of goods (or technologies) specified by the Foreign Exchange and Foreign Trade Control Law as those which require permission or approval for export, you must obtain permission or approval (or service transaction permission) pursuant to the law.

U.S. California Notice:

This product contains a lithium battery for which the following notice applies: Perchlorate Material - special handling may apply.

See "www.dtsc.ca.gov/hazardouswaste/perchlorate".

Conformance to KC Standards

Observe the following precaution if you use this product in Korea.

사 용 자 안 내 문

이 기기는 업무용 환경에서 사용할 목적으로 적합성평가를 받은 기기로서 가정용 환경에서 사용하는 경우 전파간섭의 우려가 있습니다.

- Guidance for users

This product meets the electromagnetic compatibility requirements for business use. There is a risk of radio interference when this product is used in home.

WEEE Directive



Dispose of in accordance with WEEE Directive

FH-1000/2000/3000/5000 series

Conformance to EC/EU Directives

The product is compliant with the standards below:

- EC Directive 2004/108/EC (Until April 19 2016) / EU Directive 2014/30/EU (After April 20 2016)
EN61326-1 Electromagnetic environment: Industrial electromagnetic environment (EN/IEC 61326-1 Table 2)
- Also, the following condition is applied to the immunity test of this product.
 - If the level of disturbance of the video is such that characters on the monitor are readable, the test is a pass.
- This product complies with EC/EU Directives. EMC-related performance of the OMRON devices that comply with EC/EU Directives will vary depending on the configuration, wiring, and other conditions of the equipment or control panel on which the OMRON devices are installed.
- The customer must, therefore, perform the final check to confirm that devices and the overall machine conform to EMC standards.
- If there is a need to respond to the EC / EU directive, please use by an analog RGB output.

Conformance to UL Standards (FH-1000/FH-3000 series)

This product complies with UL Standards.

- UL508

Conformance to UL Standards (FH-2000/FH-5000 series)

This product complies with UL Standards.

- UL61010-2-201

FH-L series

Conformance to EC/EU Directives

The product is compliant with the standards below:

- EC Directive 2004/108/EC (Until April 19 2016) / EU Directive 2014/30/EU (After April 20 2016)
EN61326-1 Electromagnetic environment: Industrial electromagnetic environment (EN/IEC 61326-1 Table 2)
- Also, the following condition is applied to the immunity test of this product.
 - If the level of disturbance of the video is such that characters on the monitor are readable, the test is a pass.
- This product complies with EC/EU Directives. EMC-related performance of the OMRON devices that comply with EC/EU Directives will vary depending on the configuration, wiring, and other conditions of the equipment or control panel on which the OMRON devices are installed.
- The customer must, therefore, perform the final check to confirm that devices and the overall machine conform to EMC standards.
- If there is a need to respond to the EC / EU directive, please use by an analog RGB output.

Conformance to UL Standards

This product complies with UL Standards.

- UL61010-2-201

Related Manuals

The followings are the manuals related to this manual. Use these manuals for reference.

Name of Manual	Cat. No.	Model	Purpose	Contents
Vision System FH Instruction Sheet	9608337-2	FH-1□□□ FH-1□□□-□□ FH-3□□□ FH-3□□□-□□	To confirm the safety and usage precautions of the Vision System FH series Sensor Controller.	Describes the definitions of basic terms, meaning of signal words, and precautions for correct use of FH series in the manual.
Vision System FH Instruction Sheet	3102269-4	FH-2□□□ FH-2□□□-□□ FH-5□□□ FH-5□□□-□□	To confirm the safety and usage precautions of the Vision System FH series Sensor Controller.	To confirm the safety and usage precautions of the Vision System FH series Sensor Controller.
Vision System FH-L Instruction Sheet	9606631-1	FH-L□□□ FH-L□□□-□□	To confirm the safety and usage precautions of the Vision System FH-Lite series Sensor Controller.	Describes the definitions of basic terms, meaning of signal words, and precautions for correct use of FH-L series in the manual.
Vision System FH/FHV Series User's Manual	Z365	FH-1□□□ FH-1□□□-□□ FH-2□□□	When User want to know about the FH/FHV series.	Describes the soft functions, setup, and operations to use FH/FHV series/
Vision System FH/FHV series Processing Item Function Reference Manual	Z341	FH-2□□□-□□ FH-3□□□ FH-3□□□-□□ FH-5□□□ FH-5□□□-□□ FH-L□□□ FH-L□□□-□□	When User confirm the details of each processing items at the create the measurement flow or operate it.	Describes the software functions, settings, and operations for using FH/FHV series.
Vision System FH/FHV Series User's manual for Communications Settings	Z342		When User confirm the setting of communication functions.	Describes the functions, settings, and communications methods for communication between FH/FHV series and PLCs. The following communications protocol are described. Parallel, PLC Link, EtherNet/IP, EtherCAT, and Non-procedure.
Vision System FH series Hardware Setup Manual	Z366	FH-1□□□ FH-1□□□-□□ FH-2□□□ FH-2□□□-□□ FH-3□□□ FH-3□□□-□□ FH-5□□□	When User want to know about the Hardware specifications or to setup the Sensor Controller of the Vision System FH series.	Describes FH series specifications, dimensions, part names, I/O information, installation information, and wiring information.
Vision System FH series Macro Customize Functions Programming Manual	Z367	FH-5□□□-□□ FH-L□□□ FH-L□□□-□□	When User operate or programming using Macro Customize functions.	Describes the functions, settings, and operations for using Macro Customize function of the FH series.
Vision System FH Series Operation Manual for Sysmac Studio	Z343	FH-1□□□ FH-1□□□-□□ FH-2□□□ FH-2□□□-□□ FH-3□□□ FH-3□□□-□□ FH-5□□□ FH-5□□□-□□	When User connect to NJ/NX series via EtherCAT communication.	Describes the operating procedures for setting up and operating FH series Vision Sensors from the Sysmac Studio FH Tools.

Terminology

Term	Definition
FH Series	All FH series model names as follows: FH-1□□□, FH-1□□□-□□, FH-2□□□, FH-2□□□-□□, FH-3□□□, FH-3□□□-□□, FH-5□□□, FH-5□□□-□□, FH-L□□□, FH-L□□□-□□
FH-1000 series	All FH-1□□□ series model names as follows: FH-1□□□, FH-1□□□-□□
FH-2000 series	All FH-2□□□ series model names as follows: FH-2□□□, FH-2□□□-□□
FH-3000 series	All FH-3□□□ series model names as follows: FH-3□□□, FH-3□□□-□□
FH-5000 series	All FH-5□□□ series model names as follows: FH-5□□□, FH-5□□□-□□
FH-L series	All FH-L□□□ series model names as follows: FH-L□□□, FH-L□□□-□□
FHV Series	All FHV series model names.
FZ5 series	All FZ5 series name shows the following: FZ5-6□□, FZ5-6□□-□□, FZ5-8□□, FZ5-8□□-□□, FZ5-11□□, FZ5-11□□-□□, FZ5-12□□, FZ5-12□□-□□, FZ5-L35□, FZ5-L35□-□□
FZ5-600 series	All FZ5-6□□ series name the following: FZ5-6□□, FZ5-6□□-□□
FZ5-800 series	All FZ5-8□□ series name the following: FZ5-8□□, FZ5-8□□-□□
FZ5-1100 series	All FZ5-11□□ series name the following: FZ5-11□□, FZ5-11□□-□□
FZ5-1200 series	All FZ5-12□□ series name the following: FZ5-12□□, FZ5-12□□-□□
FZ5-L series	All FZ5-L35□ series name the following: FZ5-L35□, FZ5-L35□-□□
Sensor Controller	It is a generic name of FH/FZ5 series. For FHV series, it has the same meaning as <i>Smart Camera</i> .
Measurement flow (abbreviated as <i>flow</i>)	A continuous flow of measurement processing. A measurement flow consists of a scene created from a combination of processing items.
Measurement processing	Executing processing items for inspections and measurements.
Measurement ID	Information of time when the sensor controller receives the measurement trigger and the line no. Format of measurement ID: YYYY-MM-DD_HH-MM-SS-XXXX (YYYY: Year, MM: Month, DD: Date, HH: Hour, MM: Minute, SS: Second, XXXX: Millisecond and Line number.) • Example: Measurement time: 11:10:25.500 AM, December 24, 2007 and Line 0, the measurement ID is "2007-12-24_11-10-25-5000".

Term	Definition
Processing item	<p>Any of the individual items for vision inspections that are partitioned and packaged so that they can be flexibly combined.</p> <p>These include the Search, Position Compensation, and Fine Matching items.</p> <p>Processing items can be classified for image input ([Input image]), inspection/measurement ([Measurement]), image correction ([Compensate image]), inspection/measurement support ([Support measurement]), process branching ([Branch]), results external output ([Output result]), resulting image display ([Display result]), etc.</p> <p>You can freely classify processing items to handle a wide range of applications.</p> <p>A scene (i.e., a unit for changing the measurement flow) is created by registering the processing items as units.</p>
Scene	<p>A unit for changing the measurement flow that consists of a combination of processing items.</p> <p>Scene is used because of the correspondence to the scene (i.e., type of measurement object and inspection contents) where measurements are performed.</p> <p>A scene is created for each measurement or measurement contents.</p> <p>You can easily achieve a changeover simply by changing the scene when the measurement object or inspection content changes.</p> <p>Normally you can set up to 128 scenes. If you need more than 128 scenes, you can separate them into different groups or use the Conversion Scene Group Data Tool to create a scene group that contains over 128 scenes.</p>
Processing unit (abbreviated as <i>unit</i>)	<p>A processing item that is registered in a scene.</p> <p>Numbers are assigned to processing units in order from the top and they are executed in that order.</p> <p>Processing items are registered for the processing units to create a scene (i.e., a unit for changing the measurement flow).</p>
Measurement trigger	<p>A trigger for executing measurements.</p> <p>With a parallel interface, the STEP signal is used. With a serial interface, an Execute One Measurement or a Start Continuous Measurement command is used.</p>
Test measurement	<p>A measurement that is performed to manually test (check) measurements under the conditions that are set in the currently displayed scene.</p> <p>Test measurements can be executed on an Adjustment Window. Processing is completed inside the Controller and the measurement results are not normally output on an external interface.</p> <p>However, you can select Output in Test measurement to output the measurement results after executing measurements.</p>
Single measurement	<p>A measurement that is executed only once in synchronization with the trigger input.</p>
Continuous measurement	<p>Measurements are executed repeatedly and automatically without a trigger input.</p>

Term	Definition
Operation mode	<ul style="list-style-type: none"> • Double Speed Multi-input: A mode that processes the measurement flow for the first trigger and then processes the measurement flow in parallel for the second trigger to achieve a high-speed trigger input interval. It is used together with the multi-input function. • Multi-line Random-trigger: A trigger mode that allows you to independently processing multiple measurement flows. With traditional image processing, two or more triggers cannot be acknowledged at the same time. In Multi-line Random-trigger Mode, you can randomly input multiple triggers into one Controller to independently process multiple scenes in parallel. • Non-stop adjustment mode: A mode that allows you to adjust the flow and set parameters while performing measurements. The enables adjustments without stopping the line or stopping inspections. • Standard: A logging mode that allows complete parallel processing of measurements and logging. Traditionally, logging was not possible while processing measurements. Either measurements or logging had to be given priority and the other one had to wait. With this mode, you can save the measurement images in external storage without affecting the transaction time.
Parallel processing (an option for any of the above operation modes)	<p>Parallel processing splits part of the measurement flow into two or more tasks, and processes each task in parallel to shorten the transaction time.</p> <p>Processing items for parallel processing are used so that the user can specify the required parallel processing.</p>
Multi-input function	<p>A function that is used to consecutively and quickly input images. It allows the next STEP signal to be acknowledged as soon as the image input processing is completed. There is no need to wait for measurement processing to be completed.</p> <p>You can check whether image input processing has been completed with the status of the READY signal. Even if the READY signal is ON when measurement processing is being executed, the next STEP signal can be acknowledged.</p>

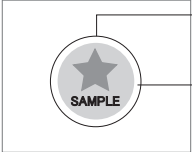
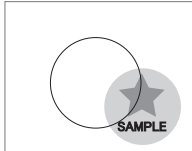
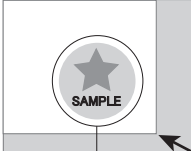
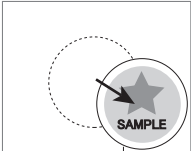
Term	Definition
Position compensation	<p>When the location and direction of measured objects are not fixed, the positional deviation between reference position and current position is calculated and measurement is performed after correcting.</p> <p>Please select processing items that are appropriate to the measurement object from processing items that are related to position compensation.</p> <ul style="list-style-type: none"> ● Reference position Measurement area and objects to be measured are correctly aligned.  <ul style="list-style-type: none"> ● When position of object to be measured is deflected Object to be measured overflows Measurement area.  <p>When position deflection correction is set in advance:</p> <div style="display: flex; justify-content: space-around;"> <div style="width: 45%;"> <p>Measurement will be carried out after moving the image for a corresponding deflection and returning to the reference position.</p>  <p>Measurement will be carried out after measured object enters into Measurement area.</p> </div> <div style="width: 45%;"> <p>Measurement will be carried out after moving the Measurement area for a corresponding deflection.</p>  </div> </div>
Reference position	The point that is always the reference. If the location of the registered model is different from the reference position, the setting should be changed in Ref. setting .
Model	The image pattern that serves as the inspection target. Characteristics portions are extracted from images of the object and registered as model registration.

Term	Definition
2's complement	<p>Binary numbers are generally used to represent negative numbers. Negative numbers are expressed by <i>Inverting all bits of a positive number and adding 1 to the result.</i> Ex. -1 is expressed as 2's complement. -1 can be calculated by 0-1.</p> $\begin{array}{r} \downarrow \text{(In the case of 1, minus 1)} \\ \square 00000000 (= 0) \\ -) 00000001 (= 1) \\ \hline 11111111 (= -1) \end{array} \leftarrow \text{"1" expresses with 2's Complement (for 8 bits)}$ <p>There are methods for simple calculation without performing this kind of computation. For instance, <i>Negative number = inverting all bits of a positive number and then adding 1 to the result.</i></p> $\begin{array}{r} 00000001 (= 1) \\ \downarrow \text{Invert all bits} \\ 11111110 \\ \downarrow \text{Plus 1} \\ \boxed{11111111} (= -1) \end{array}$ <p>The <i>first digit</i> is used to judge whether the number is positive or negative.</p> <ul style="list-style-type: none"> • When 0: Positive number (or 0) • When 1: Negative number <p>The advantage of two's complement numbers is that positive and negative numbers can be used as is in calculations. Ex. When $-1+10=9$</p> $\begin{array}{r} 11111111 (= -1) \\ +) 00001010 (= 10) \\ \hline 00001001 (= 9) \end{array}$

Revision History

A manual revision code appears as a suffix to the catalog number on the front and back covers of the manual.



Rev. Code	Rev. Date	Revision Contents
01	Apr. 2016	Original product
02	Aug. 2016	Corrected mistakes
03	Apr. 2017	Corrected mistakes and revisions for the support of NY series
04	Apr. 2017	Corrected mistakes
05	June 2017	Revisions for the support of FZ5-800 Series, FZ5-1200 Series, and FZ-S□5M3
06	July 2018	Added FH-2000 series, FH-5000 series, and FH-S□21R/FH-S□X12
07	July 2019	Removed FZ5 series, adjusted the layout, and corrected mistakes
08	Nov. 2019	Corrected mistakes

Sections in This Manual

1	Confirm the Package	1
2	Overview of FH series	2
3	Configuration	3
4	Handling and Installation Environment	4
5	Setup and Wiring	5
6	I/O Interface	6
I	Index	I

1

Confirm the Package

1-1	Sensor Controller	1 - 2
1-1-1	FH-1□□□/FH-2□□□/FH-3□□□/ FH-5□□□ Series	1 - 2
1-1-2	FH-1□□□-10/FH-2□□□-10/FH-3□□□-10/FH-5□□□-10 Series	1 - 2
1-1-3	FH-1□□□-20/FH-2□□□-20/FH-3□□□-20/FH-5□□□-20 Series	1 - 3
1-1-4	FH-L□□□ Series	1 - 3
1-1-5	FH-L□□□-10 Series	1 - 3
1-2	Sold Separately	1 - 5
1-2-1	Cameras and Related	1 - 5
1-2-2	Monitor	1 - 7
1-2-3	Lighting and Lighting Controller	1 - 8
1-2-4	Accessories	1 - 9
1-2-5	Cable	1 - 10
1-2-6	Software	1 - 12

1-1 Sensor Controller

First, please check to see whether the package has all the necessary Sensor Controller parts.

1-1-1 FH-1□□□/ FH-2□□□/ FH-3□□□/ FH-5□□□ Series

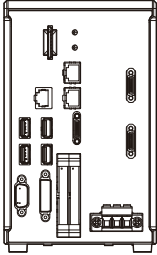

- Sensor Controller: 1
FH-1□□□/ FH-2□□□/ FH-3□□□/ FH-5□□□: 1
- Instruction sheet: 1
- Instruction Installation Manual for FH series: 1
- General Compliance Information and Instructions for EU: 1
- Membership registration: 1
- Power source: 1 (male)
FH-XCN: 1
- Ferrite core for camera cable: 2

1-1-2 FH-1□□□-10/ FH-2□□□-10/ FH-3□□□-10/ FH-5□□□-10 Series

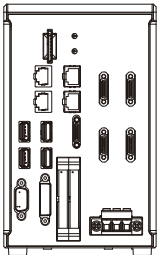

- Sensor Controller: 1
FH-1□□□-10/ FH-2□□□-10/ FH-3□□□-10/ FH-5□□□-10: 1
- Instruction sheet: 1
- Instruction Installation Manual for FH series: 1
- General Compliance Information and Instructions for EU: 1
- Membership registration: 1
- Power source: 1 (male)
FH-XCN: 1
- Ferrite core for camera cable: 4

1-1-3 FH-1□□□-20/FH-2□□□-20/FH-3□□□-20/FH-5□□□-20 Series

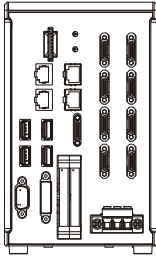

- Sensor Controller: 1
FH-1□□□-20/FH-2□□□-20/FH-3□□□-20/FH-5□□□-20: 1
- Instruction sheet: 1
- Instruction Installation Manual for FH series: 1
- General Compliance Information and Instructions for EU: 1
- Membership registration: 1
- Power source: 1 (male)
FH-XCN: 1
- Ferrite core for camera cable: 8

1-1-4 FH-L□□□ Series

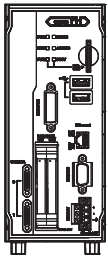

- Sensor Controller: 1
FH-L□□□: 1
- Instruction sheet: 1
- Instruction Installation Manual for FH-L series: 1
- General Compliance Information and Instructions for EU: 1
- Membership registration: 1
- Power source: 1 (male)
FH-XCN-L: 1

1-1-5 FH-L□□□-10 Series

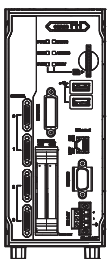





- Sensor Controller: 1
FH-L□□□-10: 1



- Instruction sheet: 1
- Instruction Installation Manual for FH-L series: 1
- General Compliance Information and Instructions for EU: 1
- Membership registration: 1
- Power source: 1 (male)
FH-XCN-L: 1

1-2 Sold Separately

1-2-1 Cameras and Related



Camera

Appearance	Type	Description	Color/ Mono- chrome	Image Ac- quisition Time ^{*1}	Model	
	High-speed Digital CMOS Cameras (Lens required)	12 megapixels (Up to four cam- eras can be con- nected to one Controller. <i>Cam- era</i> on page 1 - 5)	Color	24.9 ms ^{*2}	FH-SCX12	
			Mono- chrome		FH-SMX12	
		5 megapixels	Color	10.3 ms ^{*2}	FH-SCX05	
			Mono- chrome		FH-SMX05	
			0.4 megapixels	Color	1.9 ms ^{*3}	FH-SCX
				Mono- chrome		FH-SMX
	High-speed Digital CMOS Cameras (Lens required)	12 megapixels (Up to four cam- eras can be con- nected to one Controller. ^{*4})	Color	25.7 ms ^{*2}	FH-SC12	
			Mono- chrome		FH-SM12	
	High-speed Digital CMOS Cameras (Lens required)	4 megapixels	Color	8.5 ms ^{*2}	FH-SC04	
			Mono- chrome		FH-SM04	
		2 megapixels	Color	4.6 ms ^{*2}	FH-SC02	
			Mono- chrome		FH-SM02	
			0.3 megapixe	Color	3.3 ms	FH-SC
				Mono- chrome		FH-SM







Appearance	Type	Description	Color/ Mono- chrome	Image Ac- quisition Time *1	Model
	Digital CMOS Cameras (Lens required)	20.4 megapixels (Up to four cameras can be connected to one Controller. <i>Camera</i> on page 1 - 5)	Color	42.6 ms *2	FH-SC21R
			Mono- chrome		FH-SM21R
			5 megapixels	Color	71.7 ms
Mono- chrome	FH-SM05R				
	5 megapixels	Color	38.2 ms	FZ-SC5M3	
		Mono- chrome		FZ-S5M3	
	Digital CCD Cameras (Lens required)	2 megapixels	Color	33.3 ms	FZ-SC2M
			Mono- chrome		FZ-S2M
		0.3 megapixels	Color	12.5 ms	FZ-SC
			Mono- chrome		FZ-S
	High-speed Digital CCD Cameras (Lens required)	0.3 megapixels	Color	4.9 ms	FZ-SHC
			Mono- chrome		FZ-SH
	Small Digital CCD Cameras (Lenses for small camera required)	0.3 megapixels flat type	Color	12.5 ms	FZ-SFC
			Mono- chrome		FZ-SF
		0.3 megapixels pen type	Color	12.5 ms	FZ-SPC
			Mono- chrome		FZ-SP
 	Intelligent Compact Digital CMOS Cameras (Camera + Manual Focus Lens + High power Lighting)	Narrow view	Color	16.7 ms*5	FZ-SQ010F
		Standard view	Color		FZ-SQ050F
		Wide View (long- distance)	Color		FZ-SQ100F
		Wide View (short- distance)	Color		FZ-SQ100N

- *1. The image acquisition time does not include image conversion processing time by the Sensor Controller.
- *2. Frame rate in high speed mode when the camera is connected using two camera cables. For other conditions, please refer to 3-2-1 *High-speed digital CMOS Camera (FH-S camera series)* on page 3 - 19.
- *3. The value in high speed mode. For other information, refer to 3-2-1 *High-speed digital CMOS Camera (FH-S camera series)* on page 3 - 19.
- *4. Up to eight cameras other than 12 megapixels cameras can be connected to a FH-5050-20, FH-3050-20, FH-2050-20, or FH-1050-20.
- *5. When the built-in lighting of an FZ-SQ□□□□ is used, it may not be possible to shorten the processing time due to restrictions on the light emission time.

Camera Mounting Bracket

Appearance	Description		Model
	For Intelligent Compact Digital Camera	Mounting Bracket	FQ-XL
		Precise Mounting Brackets	FQ-XL2
		Polarizing Filter Attachment (Packaged item)	FQ-XF1
-	Mounting Base for FZ-S□, FH-S□05R, FH-S□X		FZ-S-XLC
	Mounting Base for FZ-S□2M		FZ-S2M-XLC
	Mounting Base for FZ-SH□		FZ-SH-XLC
	Mounting Base for FH-S□, FZ-S□5M□, FH-S□X05, FH-S□02, FH-S□04, FH-S□X12, FH-S□21R		FH-SM-XLC
	Mounting Base for FH-S□12		FH-SM12-XLC
	M42 - F Mount Conversion Adapter		FH-ADF/M42-10

Camera Cable

Appearance	Description	Model ^{*1}
	Camera Cable Cable length: 2 m, 3 m, 5 m, or 10 m ^{*2}	FZ-V3 □M
	Bend resistant Camera Cable Cable length: 2 m, 3 m, 5 m, or 10 m ^{*2}	FZ-VSB3 □M
	Right-angle Camera Cable ^{*3} Cable length: 2 m, 3 m, 5 m, or 10 m ^{*2}	FZ-VSL3 □M
	Bend resistant Right-angle Camera Cable ^{*3} Cable length: 2 m, 3 m, 5 m, or 10 m ^{*2}	FZ-VSLB3 □M
	Long-distance Camera Cable Cable length: 15 m ^{*2}	FZ-VS4 15M
	Long-distance Right-angle Camera Cable ^{*3} Cable length: 15 m ^{*2}	FZ-VSL4 15M
	Cable Extension Unit Up to two Extension Units and three Cables can be connected (Maximum cable length: 45 m ^{*2})	FZ-VSJ

*1. Insert the cables length into □ in the model number as follows. 2 m = 2, 3 m = 3, 5 m = 5, 10 m = 10

*2. The maximum cable length depends on the Camera being connected, and the model and length of the Cable being used. For further information, please refer to 3-3-4 *Cable Connection Table* on page 3 - 39 and 3-3-5 *Cable Extension Units* on page 3 - 43.

When a high-speed digital CMOS camera FH-S□02/-S□04/-S□12 is used in the high speed digital mode of transmission speed, two camera cables are required.



*3. This Cable has an L-shaped connector on the Camera end.

1-2-2 Monitor

Touch Panel Monitor and Cables

Appearance	Description	Model
	Touch Panel Monitor 12.1 inches (for FH Sensor Controllers) *1	FH-MT12



*1. FH Series Sensor Controllers version 5.32 or higher is required.

Appearance	Description	Model
	DVI-Analog Conversion Cable for Touch Panel Monitor Cable length: 2 m, 5 m or 10 m	FH-VMDA □M *1
	RS-232C Cable for Touch Panel Monitor Cable length: 2 m, 5 m or 10 m	XW2Z-□□ □PP-1 *2
	USB Cable for Touch Panel Monitor Cable length: 2 m or 5 m	FH-VUAB □M *1

*1. Insert the cables length into □ in the model number as follows. 2 m = 2, 5 m = 5, 10 m = 10



*2. Insert the cables length into □□□ in the model number as follows. 2 m = 200, 5 m = 500, 10 m = 010.

LCD Monitor and Cable

Appearance	Description	Model
	LCD Monitor 8.4 inches for Box-type Controllers *1	FZ-M08
	LCD Monitor Cable When you connect a LCD Monitor FZ-M08 to FH sensor controller, please use it in combination with a DVI-I -RGB Conversion Connector FH-VMRGB.	FZ-VM 2M FZ-VM 5M
	DVI-I -RGB Conversion Connector	FH-VMRGB











*1. It can be used in FH series.

1-2-3 Lighting and Lighting Controller

Appearance	Description		Model
-	External Lighting	-	FLV Series
-	External Lighting	-	FL Series
	Lighting Controller (Required to control external lighting from a Controller)	For FLV-Series	Camera Mount Lighting Controller
			Analog Lighting Controller
		For FL-Series	Camera Mount Lighting Controller
			FL-TCC Series





For the method of setting the lighting controller, please refer to the respective instruction manual.

1-2-4 Accessories

Appearance	Description				Model
	USB Memory		2 GB		FZ-MEM2G
			8 GB		FZ-MEM8G
	SD card		2 GB		HMC-SD291
			4 GB		HMC-SD491
	USB/Monitor Switcher				FZ-DU
-	Mouse - Driverless wired mouse (A mouse that requires the mouse driver to be installed is not supported.)				-
	EtherCAT junction slaves	3 ports	Power supply voltage: 20.4 VDC to 28.8 VDC (24 VDC -15 % to +20 %)	Current consumption: 0.22 A	GX-JC03
		6 ports			GX-JC06
	Industrial Switching Hubs for EtherNet/IP and Ethernet	3 ports	Failure detection: None	Current consumption: 0.22 A	W4S1-03B
		5 ports	Failure detection: None		W4S1-05B
			Failure detection: Supported		W4S1-05C
-	Calibration Plate				FZD-CAL
	Common items related to DIN rail (for FH-L550/-L550-10)	DIN rail mounting bracket			FH-XDM-L
		DIN 35 mm rail	• Length: 75.5/95.5/115.5/200 cm	PHOENIX CONTACT	NS 35/7.5 PERF
			• Height: 7.5 mm		NS 35/15 PERF
			• Material: Iron		
			• Surface: Conductive		
			• Length: 75.5/95.5/115.5/200 cm		
			• Height: 15 mm		
			• Material: Iron		
			• Surface: Conductive		
		End plate	Need 2 pieces each Sensor Controller	PHOENIX CONTACT	CLIPFIX 35

1-2-5 Cable

Parallel I/O Cables and Encoder Cable

Appearance	Description	Model
	Parallel I/O Cable *1 Cable length: 2 m, 5 m or 15 m	XW2Z-S013-□ *2
	Parallel I/O Cable for Connector-terminal Conversion Unit *1 Cable length: 0.5 m, 1 m, 1.5 m, 2 m, 3 m, 5 m	XW2Z-□□□EE *3
	Connector-Terminal Block Conversion Units, General-purpose devices	XW2R-□34GD-T *4
	Encoder Cable for line-driver Cable length: 1.5 m	FH-VR 1.5M

*1. 2 Cables are required for all I/O signals.

*2. Insert the cables length into □ in the model number as follows. 2 m = 2, 5 m = 5, 15 m = 15

*3. Insert the cables length into □□□ in the model number as follows. 0.5 m = 050, 1 m = 100, 1.5 m = 150, 2 m = 200, 3 m = 300, 5 m = 500



*4. Insert the wiring method into □ in the model number as follows. Phillips screw = J, Slotted screw (rise up) = E, Push-in spring = P



Refer to the *XW2R Series catalog (Cat. No. G077)* for details.

Recommended EtherCAT and EtherNet/IP Communications Cables

Use Straight STP (shielded twisted-pair) cable of category 5 or higher with double shielding (braiding and aluminum foil tape) for EtherCAT.

Use Straight or cross STP (shielded twisted-pair) cable of category 5 or higher for EtherNet/IP.

Appearance	Description	Model
	For Ether-CAT Cable with Standard type Connectors on Both Ends (RJ45/RJ45) <ul style="list-style-type: none"> Wire Gauge and Number of Pairs: AWG27, 4-pair Cable Cable Sheath material: LSZH *1 Cable color: Blue, Yellow, or Green Cables length: 0.2 m, 0.3 m, 0.5 m, 1 m, 1.5 m, 2 m, 3 m, 5 m, 7.5 m, 10 m, 15 m, 20 m 	XS6W-6LSZH8S S□CM-Y
	Cable with Rugged type Connectors on Both Ends (RJ45/RJ45) <ul style="list-style-type: none"> Wire Gauge and Number of Pairs: AWG22, 2-pair Cable Cables length: 0.3 m, 0.5 m, 1 m, 2 m, 3 m, 5 m, 10 m, 15 m 	XS5W-T421- □MD-K

Appearance	Description			Model		
		Cable with Rugged type Connectors on Both Ends (M12/RJ45)		XS5W-T421- □MC-K		
		<ul style="list-style-type: none"> Wire Gauge and Number of Pairs: AWG22, 2-pair Cable Cables length: 0.3 m, 0.5 m, 1 m, 2 m, 3 m, 5 m, 10 m, 15 m 				
		Cable with Rugged type Connectors on Both Ends (M12 L/RJ45)		XS5W-T422- □MC-K		
		<ul style="list-style-type: none"> Wire Gauge and Number of Pairs: AWG22, 2-pair Cable Cables length: 0.3 m, 0.5 m, 1 m, 2 m, 3 m, 5 m, 10 m, 15 m 				
-	For Ether-CAT and EtherNet/IP	Wire Gauge and Number of Pairs: AWG24, 4-pair Cable	Cables	Hitachi Metals, Ltd.	NETSTAR-C5E SAB 0.5 x 4P CP *2	
-				Kuramo Electric Co.		KETH-SB *2
-				SWCC Showa Cable Systems Co.		FAE-5004 *2
-				JMACS Japan Co.,Ltd.		IETP-SB *2
-			RJ45 Connectors	Panduit Corporation	MPS588-C *2	
-		Wire Gauge and Number of Pairs: AWG22, 2-pair Cable	Cables	Kuramo Electric Co.	KETH-PSB-OMR *3	
-				JMACS Japan Co.,Ltd.		PNET/B *3
-				SWCC Showa Cable Systems Co.		FAE-5002 *3
				RJ45 Assembly Connector	OMRON	XS6G-T421-1
-		For Ether-Net/IP	Wire Gauge and Number of Pairs: 0.5mm x 4P	Cables	Fujikura Ltd.	F-LINK-E 0.5mm x 4P *4
-	RJ45 Connectors				Panduit Corporation	

- *1. The lineup features Low Smoke Zero Halogen cables for in-cabinet use and PUR cables for out-of-cabinet use.
- *2. We recommend you to use above cable for EtherCAT and EtherNet/IP, and RJ45 Connector together.
- *3. We recommend you to use above cable for EtherCAT and EtherNet/IP, and RJ45 Assembly Connector together.
- *4. We recommend you to use above cable for EtherNet/IP and RJ45 Connectors together.



Precautions for Correct Use

Please be careful while cable processing, for EtherCAT, connectors on both ends should be shield connected and for EtherNet/IP, connectors on only one end should be shield connected.

1-2-6 Software

Product	Specifications	Specifications		Model
		Number of licenses	Media	
Sysmac Studio Standard Edition Ver.1. □□	The Sysmac Studio is the software that provides an integrated environment for setting, programming, debugging and maintenance of machine automation controllers including CPU units of NJ/NX Series and industrial PCs of NY Series, EtherCat Slave, and the HMI. Sysmac Studio runs on the following OS. • OS: /Windows 7 (32-bit/64-bit version) /Windows 8 (32-bit/64-bit version) /Windows 8.1 (32-bit/64-bit version) /Windows 10 (32-bit/64-bit version) This software also includes the function of the Vision edition. For more details about other compatible models and functions, refer to our product information.	- (Media only)	DVD*1	SYSMAC-SE200D
		1 license	-	SYSMAC-SE201L
		3 license	-	SYSMAC-SE203L
		10 license	-	SYSMAC-SE210L
		30 license	-	SYSMAC-SE230L
		50 license	-	SYSMAC-SE250L
Sysmac Studio Vision Edition Ver.1.□□*2*3	Sysmac Studio Vision Edition is a limited license that provides selected functions required for FH-series/FHV-series/FQ-M-series Vision Sensor settings.	1 license	-	SYSMAC-VE001L

Note:

- Site licenses are available for users who will run Sysmac Studio on multiple computers. Ask your OMRON sales representative for details.
- Sysmac Studio version 1.07 or higher supports the FH Series.

*1. The same media is used for both the Standard Edition and the Vision Edition.

*2. With the Vision Edition, you can use only the setup functions for FH-series/FHV-series/FQ-M-series Vision Sensors.

*3. This product is a license only. You need the Sysmac Studio Standard Edition DVD media to install it.

Product	Specifications			Model
		Number of licenses	Media	
Application Producer	Software components that provide a development environment to further customize the standard controller features of the FH Series. System requirements: <ul style="list-style-type: none"> • CPU: Intel Pentium Processor (SSE2 or higher) • OS: Windows 7 Professional (32/64bit) or Enterprise (32/64bit) or Ultimate (32/64bit), Windows 8 Pro (32/64bit) or Enterprise (32/64bit), Windows 8.1 Pro (32/64bit) or Enterprise (32/64bit) or Windows 10 Pro (32/64bit) or Enterprise (32/64bit) • .NET Framework: .NET Framework 3.5 SP1 or higher • Memory: At least 2 GB RAM Available disk space: At least 2 GB • Browser: Microsoft® Internet Explorer 6.0 or later • Display: XGA (1024 x 768), True Color (32-bit) or higher • Optical drive: CD/DVD drive • The following software is required to customize the software: Microsoft® Visual Studio® 2010 Professional or Microsoft® Visual Studio® 2008 Professional or Microsoft® Visual Studio® 2012 Professional 	- (Media only)	CD-ROM	FH-AP1
		1 license	-	FH-AP1L

2

Overview of FH series

2-1	Overview of System	2 - 2
2-1-1	Basic System of Measurement	2 - 2
2-1-2	FH-1000/FH-2000/FH-3000/FH-5000 Series	2 - 4
2-1-3	FH-L Series	2 - 5
2-2	System Configuration	2 - 6
2-2-1	FH-1000/2000/3000/5000 Series	2 - 6
2-2-2	FH-L Series	2 - 7
2-3	Flow of Use Procedure	2 - 8

2-1 Overview of System

2-1-1 Basic System of Measurement

An FH series Sensor Controller uses pre-built packages that contain all the processing tasks (for image input, measurement processing, displays, outputs, etc.) that are required for vision inspections. You arrange these packaged processes in order of execution of the vision inspection.

An FH series Sensor Controller executes vision inspections according to user-created flows.



Additional Information

In the FH series Sensor Controller, a flow that contains packaged processes that are arranged in order of execution of processing items and image processing is called a measurement flow. Processing items and measurement flows can have more than one setting. You can switch the setting based on the scene to inspect. (Refer to the *Vision System FH/FHV series User's Manual (Cat. No. Z365).*)

Concept of Measurement Processing

When the FH receives a measurement trigger from the PLC or other external device, the image input from a Camera, measurement processing, and output of measurement results (e.g., OK/NG judgement results) are executed in the order that those processing items are registered in the measurement flow.

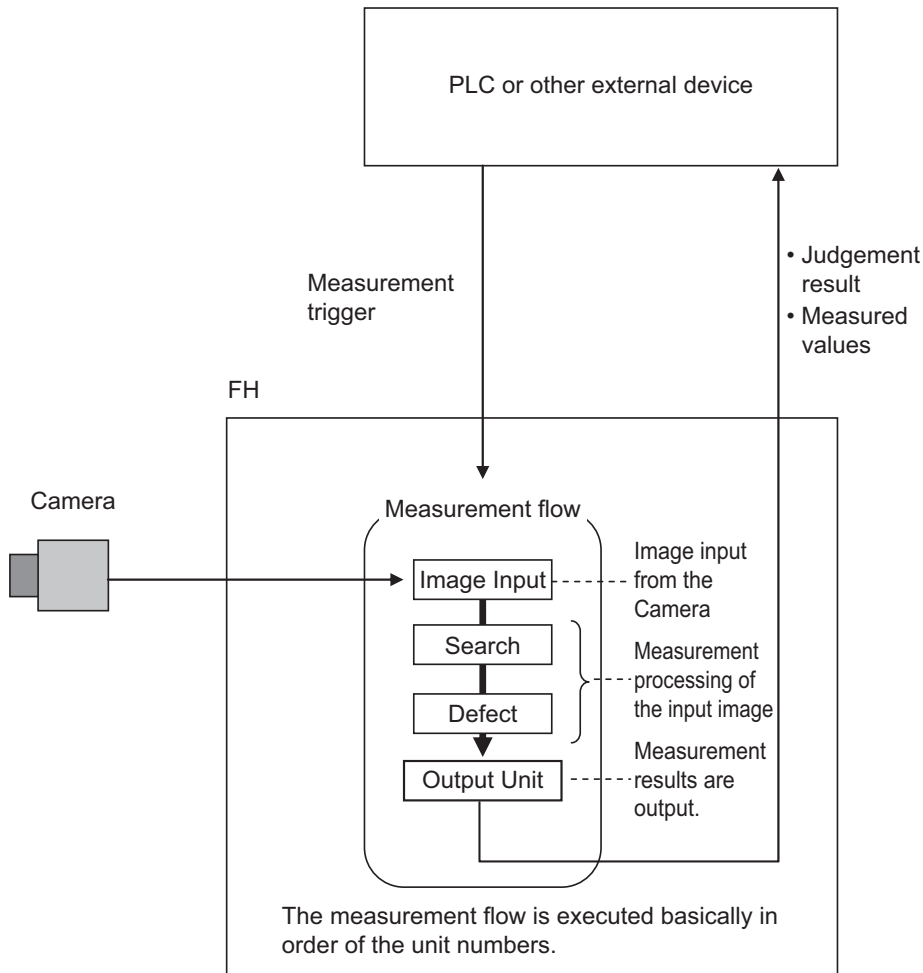

In the measurement flow, you can change the processing to execute based on the inspection results or input conditions of the vision inspection.

You can use macro processing to execute pre-packaged processing items and functions in the FH to create original programs. This allows you to create original measurement processes, display processing, input and output processing, and settings dialog boxes that are custom-tailored to your application.

2-1-2 FH-1000/FH-2000/FH-3000/FH-5000 Series

Vision System FH-1000/2000/3000/5000 series is the BOX type Sensor Controller having functions and high-speed needed to incorporate with a machine, and safety, reliability, and maintainability as an industrial controller.

This series includes the conventional image processing functions and added functions needed to incorporate with a machine. As Sensor Controller supporting high-speed communications, with EtherCAT, it enables synchronous control with connecting to input and output devices such and a programmable controller.

This series can connect with up to eight cameras and transmits images faster than that in the conventional models.

OMRON provides Sysmac device designed by unified communication specifications and User Interface Specifications. Vision System FH-1000/2000/3000/5000 series can be easily connected with NJ/NX/NY-series Controller and Sysmac devices such as EtherCAT slaves by using the automation software Sysmac Studio and which are designed to meet the optimum functions and operations. The example of a system configuration is shown below.

EtherCAT Connection for FH Series

Example of the FH Sensor Controllers (4-camera type)

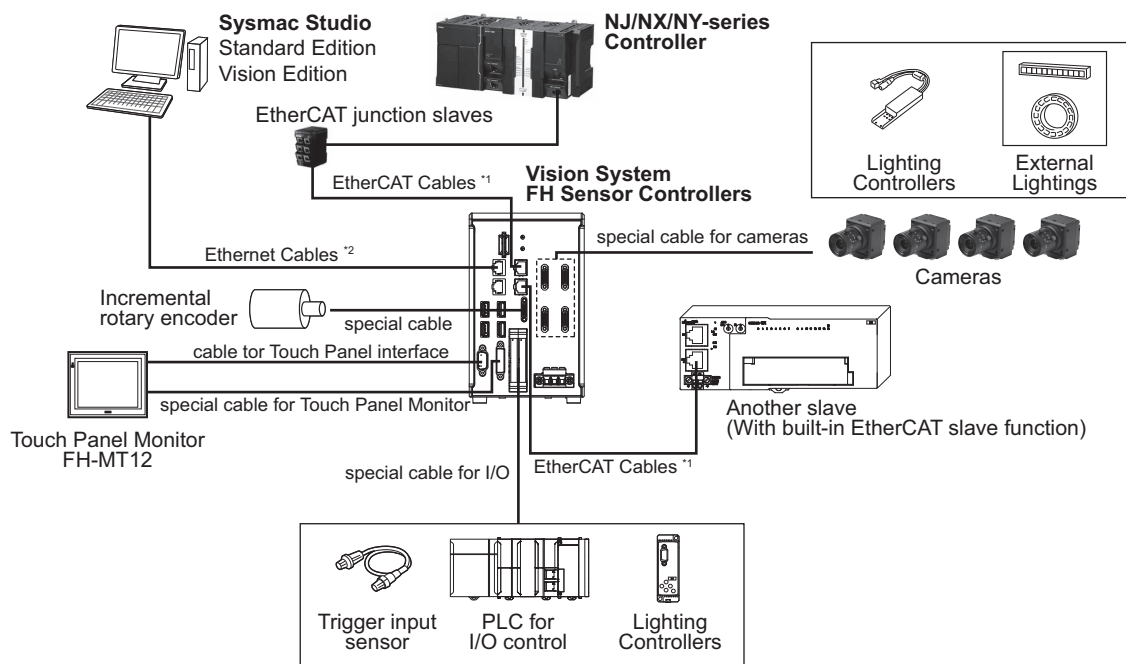

*1. To use STP (shielded twisted-pair) cable of category 5 or higher with double shielding (braiding and aluminum foil tape) for EtherCAT and RJ45 connector.

*2. To use STP (shielded twisted-pair) cable of category 5 or higher for Ethernet and RJ45 connector.

2-1-3 FH-L Series

Vision System FH-L series is the small and low-cost BOX type Sensor Controller having functions and high-speed needed to be built into a machine, and safety, reliability, and maintainability as an industrial controller.

This series can connect with up to four cameras and transmits images faster than that in the conventional models.

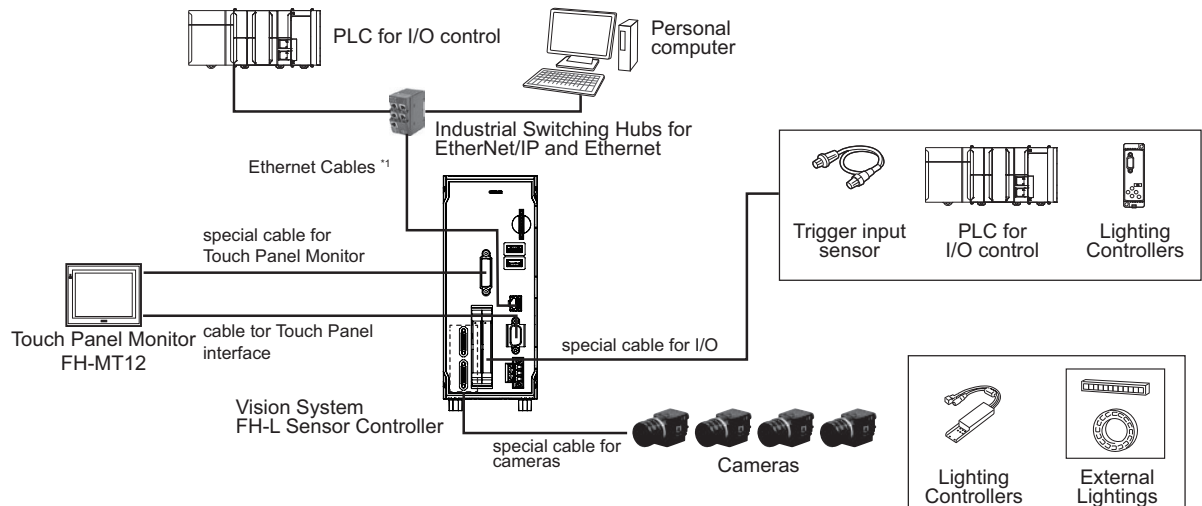

*1. To use STP (shielded twisted-pair) cable of category 5 or higher for Ethernet and RJ45 connector.

2-2 System Configuration

2-2-1 FH-1000/2000/3000/5000 Series

* Items indicated with an asterisk are dedicated items, and cannot be substituted.

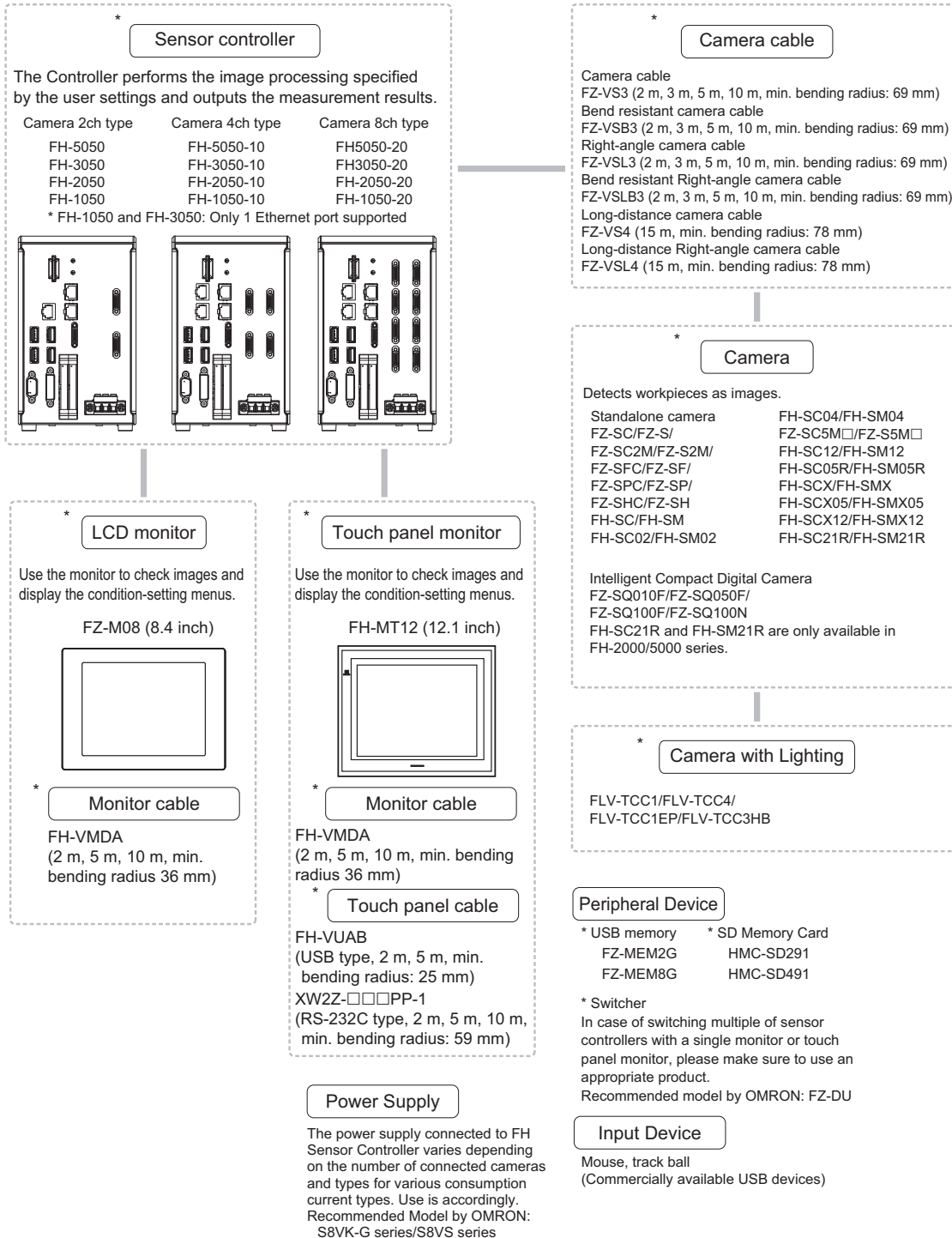

2-2-2 FH-L Series

* Items indicated with an asterisk are dedicated items, and cannot be substituted.

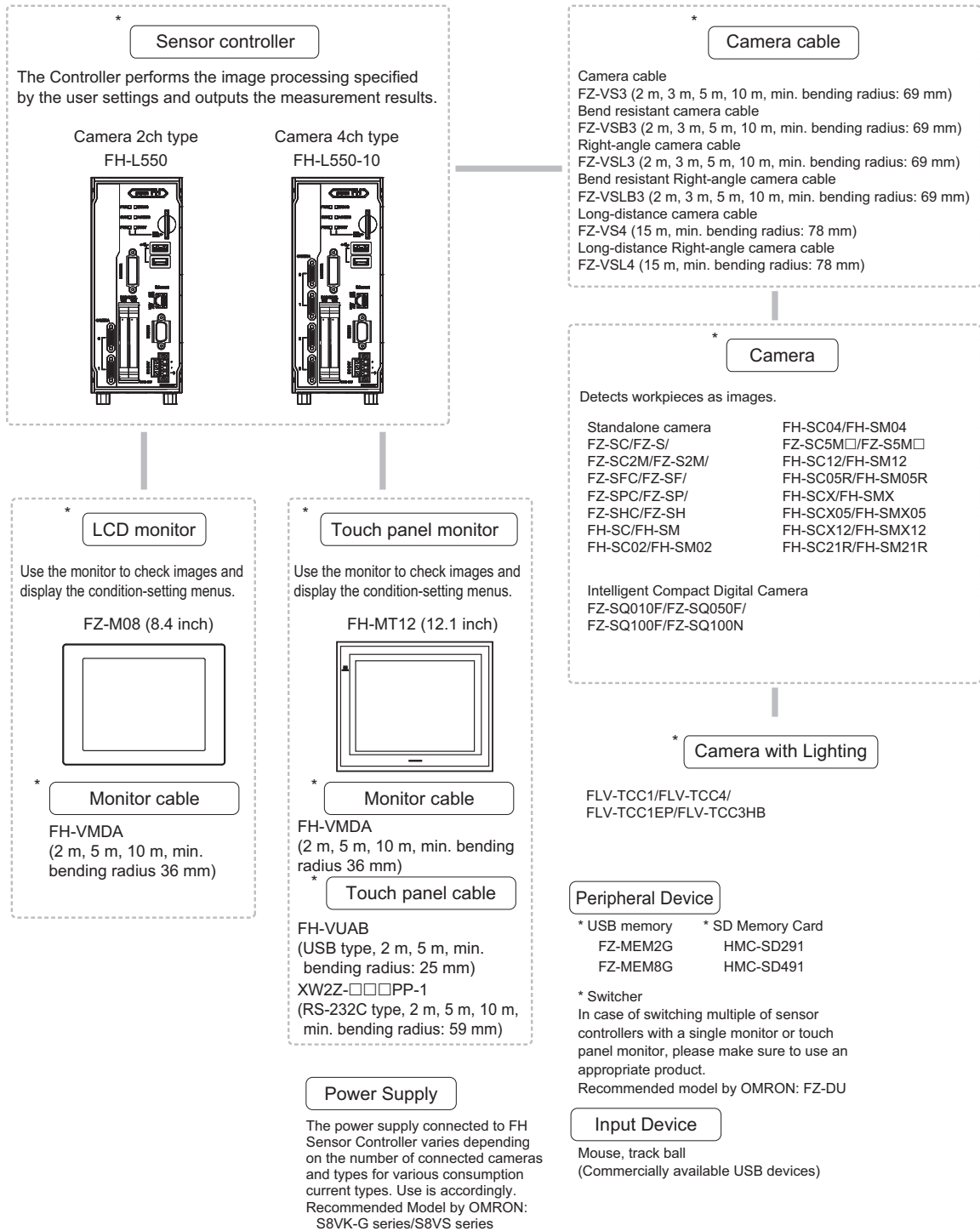

2-3 Flow of Use Procedure

The following table shows the flow for using the FH.

Procedure	Description	Reference
Preparations	Installation and Wiring	<i>Section 4 Handling and Installation Environment</i> on page 4 - 1 <i>Section 5 Setup and Wiring</i> on page 5 - 1
	↓	
	Turning ON Power	<i>5-1 When turning ON and OFF</i> on page 5 - 2
	↓	
	Language Selection in Dialog Box (only when the Sensor Controller is started for the first time)	<i>Vision System FH/FHV series User's Manual (Cat.No. Z365)</i>
	↓	
	Main Window (Layout 0) Display	<i>Vision System FH/FHV series User's Manual (Cat.No. Z365)</i>
	↓	
	Camera Adjustments (Display the settings dialog box for a Camera Image Input processing item.)	<i>Vision System FH/FHV series User's Manual (Cat.No. Z365)</i>
	↓	
	Select Tool - System settings , and then under Startup setting , set the settings for <i>Basic, Communication, and Operation mode</i> .	<i>Vision System FH/FHV series User's Manual (Cat.No. Z365)</i>
	↓	
	Click the Data save button, and then select Function - System restart .	<i>Vision System FH/FHV series User's Manual (Cat.No. Z365)</i>
↓		
Select Tool - System settings , and then set the settings for <i>Camera, Communication and Other</i> .	<i>Vision System FH/FHV series User's Manual (Cat.No. Z365)</i>	
↓		
Click the Data save button.	<i>Vision System FH/FHV series User's Manual (Cat.No. Z365)</i>	
↓		
Scene Editing	In the Main Window (layout 0), edit the measurement flow. <ul style="list-style-type: none"> • Register processing items. • Set the properties for each processing item. 	<i>Vision System FH/FHV series User's Manual (Cat.No. Z365)</i>
	↓	
	Click the Data save button.	<i>Vision System FH/FHV series User's Manual (Cat.No. Z365)</i>
↓↑		

Procedure	Description	Reference
Testing	Execute test measurements. (In the Main Window (layout 0), click the Measure button.)	<i>Vision System FH/FHV series User's Manual (Cat.No. Z365)</i>
	↓	
	Adjust the parameters for each processing item.	<i>Vision System FH/FHV series Processing Item Function Reference Manual (Cat. No. Z341)</i>
	↓	
	Click the Data save button.	<i>Vision System FH/FHV series User's Manual (Cat.No. Z365)</i>
↓		
Measuring (Operation)	In the Main Window (layout 0), click the Switch layout button, and then select <i>Main Window (Layout 1)</i> .	<i>Vision System FH/FHV series User's Manual (Cat.No. Z365)</i>
	↓	
	In the Main Window (layout 1), check the communications with the PLC.	<i>Vision System FH/FHV series User's Manual for Communications Settings (Cat. No. Z342)</i>
	↓	
	In the Main Window (layout 1), execute commands from the PLC, such as measurement trigger commands.	<i>Vision System FH/FHV series User's Manual for Communications Settings (Cat. No. Z342)</i>
↓		
Management and Analysis	Save and analyze measurement data and images.	<i>Vision System FH/FHV series User's Manual for Communications Settings (Cat. No. Z342)</i>

3

Configuration

3-1	Sensor Controller	3 - 3
3-1-1	FH-1000/2000/3000/5000 Series	3 - 3
3-1-2	FH-L Series	3 - 14
3-2	Camera	3 - 19
3-2-1	High-speed digital CMOS Camera (FH-S camera series)	3 - 19
3-2-2	Digital CMOS Camera	3 - 24
3-2-3	Digital CCD Camera: FZ-S Camera Series	3 - 27
3-2-4	High-speed Digital CCD Camera: FZ-SH Camera Series	3 - 29
3-2-5	Small Digital CCD Cameras: FZ-S Camera Series	3 - 30
3-2-6	Intelligent Compact Digital CMOS Camera: FZ-S camera Series	3 - 33
3-3	Camera Cable	3 - 36
3-3-1	Camera Cable and Right-angle Camera Cable	3 - 36
3-3-2	Bend resistant Camera Cable and Bend resistant Right-angle Camera Cable	3 - 37
3-3-3	Long-distance Camera Cable and Long-distance Right-angle Camera Cable	3 - 38
3-3-4	Cable Connection Table	3 - 39
3-3-5	Cable Extension Units	3 - 43
3-4	Lens	3 - 47
3-4-1	C-mount Lens for 1/3-inch Image Sensor (SV-V Series)	3 - 47
3-4-2	C-mount Lens for 2/3-inch Image Sensor (SV-H Series)	3 - 48
3-4-3	C-mount Lens for 1-inch Image Sensor (VS-H1 Series)	3 - 49
3-4-4	C-mount Lens for 4/3-inch Image Sensor (VS-LLD Series)	3 - 50
3-4-5	M42-mount Lens for Large Image Sensor (VS-L/M42-10 Series)	3 - 51
3-4-6	Lenses for Small Camera (FZ-LES Series)	3 - 51
3-4-7	Vibration and Shock Resistant C-mount Lens for 2/3-inch Image Sensor (VS-MCA Series)	3 - 52
3-4-8	Vibration and Shock Resistant C-mount Lens for 1-inch Image Sensor (VS-MCH Series)	3 - 54
3-4-9	Vibration and Shock Resistant C-mount Lens for 1-inch Image Sensor (VS-MCH1 Series)	3 - 57
3-4-10	Vibration and Shock Resistant M42-mount Lens for 1.8-inch Image Sensor (VS-MCL/M42-10 Series)	3 - 60
3-4-11	High-resolution Telecentric Lens for C-mount Lens for 2/3-inch Image Sensor (VS-TCH Series)	3 - 62
3-4-12	High-resolution Telecentric Lens for C-mount Lens for 1.1-inch Image Sensor (VS-TEV Series)	3 - 64
3-4-13	Extension Tubes	3 - 65
3-4-14	Meaning of Optical Chart	3 - 66

3-5	Touch Panel Monitor and Cable.....	3 - 82
3-6	LCD and Cable.....	3 - 88
3-7	Sysmac Studio	3 - 91

3-1 Sensor Controller

3-1-1 FH-1000/2000/3000/5000 Series

Specification

● FH-5000/FH-2000

Series		FH-5000 Series			FH-2000 Series		
Type		High-speed, Large-capacity Controller(4 cores)			High-speed, Large-capacity Controller(2 cores)		
Model		FH-5050	FH-5050-10	FH-5050-20	FH-2050	FH-2050-10	FH-2050-20
Controller Type		Box type					
Parallel IO polarity		NPN/PNP (common)					
Main Functions	Operation Mode	Standard	Yes				
		Double Speed Multi-input	Yes				
		Non-stop adjustment mode	Yes				
		Multi-line random-trigger mode	Yes (Maximum 8 lines)* ¹				
Parallel Processing		Yes					
Number of Connectable Camera		2	4	8	2	4	8
Supported Camera	FH-S series camera	All of the FH-S series cameras are connectable.		All of the FH-S series cameras are connectable. * ²	All of the FH-S series cameras are connectable.		All of the FH-S series cameras are connectable. * ²
	FZ-S series camera	All of the FZ-S series cameras are connectable.					
Camera I/F		OMRON I/F					
Possible Number of Captured Images		Refer to <i>About Number of Logging Images</i> or <i>About Max. Number of Loading Images during Multi-input</i> in the <i>Vision System FH/FHV series User's Manual (Cat.No. Z365)</i> .					
Possible Number of Logging Images to Sensor Controller							

Series		FH-5000 Series			FH-2000 Series		
Type		High-speed, Large-capacity Controller(4 cores)			High-speed, Large-capacity Controller(2 cores)		
Model		FH-5050	FH-5050-10	FH-5050-20	FH-2050	FH-2050-10	FH-2050-20
	Possible Number of Scenes	128					
	Operating on UI	USB Mouse	Yes (wired USB and driver is unnecessary type)				
		Touch Panel	Yes (RS-232C/USB connection: FH-MT12)				
	Setup	Create the processing flow using Flow editing.					
	Language	Japanese, English, Simplified Chinese, Traditional Chinese, Korean, German, French, Spanish, Italian, Vietnamese, Polish					
External Interface	Serial Communication	RS-232C x 1					
	Ethernet Communication	Protocol	Non-procedure (TCP/UDP)				
		I/F	1000BASE-T x 2				
	EtherNet/IP Communication	Yes (Target/Ethernet port)					
	PROFINET Communication	<ul style="list-style-type: none"> • Yes (Slave/Ethernet port) • Conformance class A 					
	EtherCAT Communication	Yes (slave)					
	Parallel I/O	12 inputs/31 outputs: Use 1 Line. Operation mode: Except Multi-line random-trigger mode. 17 inputs/37 outputs: Use 2 Line. Operation mode: Multi-line random-trigger mode. 14 inputs/29 outputs: Use 3 to 4 Line. Operation mode: Multi-line random-trigger mode. 19 inputs/34 outputs: Use 5 to 8 Line. Operation mode: Multi-line random-trigger mode.					
	Encoder Interface	Input voltage: 5 V \pm 5% Signal: RS-422A Line Driver Level Phase A/B/Z: 1 MHz					
	Monitor Interface	DVI-I output (Analog RGB & DVI-D single link) x 1					
	USB I/F	USB2.0 host x 2 (BUS Power: 5 V/0.5 A per port) USB3.0 host x 2 (BUS Power: 5 V/0.9 A per port)					
	SD Card I/F	SDHC x 1					

Series		FH-5000 Series			FH-2000 Series		
Type		High-speed, Large-capacity Controller(4 cores)			High-speed, Large-capacity Controller(2 cores)		
Model		FH-5050	FH-5050-10	FH-5050-20	FH-2050	FH-2050-10	FH-2050-20
Indicator Lamps	Main	POWER: Green ERROR: Red RUN: Green ACCESS: Yellow					
	Ethernet	NET RUN1: Green LINK/ACT1: Yellow NET RUN2: Green LINK/ACT2: Yellow					
	SD Card	SD POWER: Green SD BUSY: Yellow					
	EtherCAT	ECAT RUN: Green LINK/ACT IN: Green LINK/ACT OUT: Green ECAT ERR: Red					
Supply Voltage		20.4 VDC to 26.4 VDC					
Current consumption	<ul style="list-style-type: none"> When connecting an intelligent compact digital camera When connecting the following lighting or lighting controllers without an external power supply <ul style="list-style-type: none"> - FLV-TCC1 - FLV-TCC4 - FLV-TCC3HB - FLV-TCC1EP - FL-TCC1 When connecting the following lighting or lighting controllers <ul style="list-style-type: none"> - FL-TCC1PS - FL-MD□MC 	5.6A max.	7.7A max.	12.2A max.	4.6A max.	6.6A max.	11.2A max.
	Other than above	4.5A max.	5.5A max.	7.3A max.	3.5A max.	4.3A max.	6.3A max.
Built-in FAN		Yes					
Usage Environment	Ambient temperature range	Operating: 0°C to +45°C Storage: -20 to +65°C (with no icing or condensation)			Operating: 0°C to +50°C Storage: -20 to +65°C (with no icing or condensation)		
	Ambient humidity range	Operating and storage: 35 to 85% (with no condensation)					
	Ambient atmosphere	No corrosive gases					
	Vibration tolerance	Oscillation frequency: 10 to 150 Hz, Half amplitude: 0.1 mm, Acceleration: 15 m/s ² Sweep time: 8 minute/count, Sweep count: 10, Vibration direction: up and down/front and behind/left and right					

Series		FH-5000 Series			FH-2000 Series		
Type		High-speed, Large-capacity Controller(4 cores)			High-speed, Large-capacity Controller(2 cores)		
Model		FH-5050	FH-5050-10	FH-5050-20	FH-2050	FH-2050-10	FH-2050-20
Shock resistance		Impact force: 150 m/s ² Test direction: up and down/front and behind/left and right					
Noise immunity	Fast Transient Burst	<ul style="list-style-type: none"> DC power: Direct infusion: 2 kV, Pulse rising: 5 ns, Pulse width: 50 ns, Burst continuation time: 15 ms/0.75 ms, Period: 300 ms, Application time: 1 min. I/O line: Direct infusion: 1 kV, Pulse rising: 5 ns, Pulse width: 50 ns, Burst continuation time: 15 ms/0.75 ms, Period: 300 ms, Application time: 1 min. 					
Grounding		Class D grounding (100 Ω or less grounding resistance) *3					
External Features	Dimensions	190 mm x 115 mm x 182.5 mm Note Height: Including the rubber at the base.					
	Weight	Ap-prox.3.4kg	Ap-prox.3.6kg	Ap-prox.3.6kg	Ap-prox.3.4kg	Ap-prox.3.6kg	Ap-prox.3.6kg
	Degree of protection	IEC60529 IP20					
	Case material	Cover: zinc-plated steel plate, Side plate: aluminum (A6063)					

*1. According to the CPU performance, FH-2000 series is recommended to use up to two lines in this mode.

*2. When 12 megapixels/20.4 megapixels cameras: Max. 4 cameras are connectable. When use except 12 megapixels/20.4 megapixels cameras: Max. 8 cameras are connectable.

*3. Existing the third class grounding

● FH-3000/FH-1000

Series		FH-3000 Series			FH-1000 Series		
Type		Standard Controller(4 cores)			Standard Controller(2 cores)		
Model		FH-3050	FH-3050-10	FH-3050-20	FH-1050	FH-1050-10	FH-1050-20
Controller Type		Box type					
Parallel IO polarity		NPN/PNP (common)					
Main Functions	Operation Mode	Standard	Yes				
		Double Speed Multi-input	Yes				
		Non-stop adjustment mode	Yes				
		Multi-line random-trigger mode	Yes (Maximum 8 lines)*1				
Parallel Processing		Yes					

Series		FH-3000 Series			FH-1000 Series		
Type		Standard Controller(4 cores)			Standard Controller(2 cores)		
Model		FH-3050	FH-3050-10	FH-3050-20	FH-1050	FH-1050-10	FH-1050-20
Number of Connectable Camera		2	4	8	2	4	8
Supported Camera	FH-S series camera	FH-S series cameras except FH-SM21R/SC21R are connectable.		FH-S series cameras except FH-SM21R/SC21R are connectable. *2	FH-S series cameras except FH-SM21R/SC21R are connectable.		FH-S series cameras except FH-SM21R/SC21R are connectable. *2
	FZ-S series camera	All of the FZ-S series cameras are connectable.					
Camera I/F		OMRON I/F					
Possible Number of Captured Images		Refer to <i>About Number of Logging Images</i> or <i>About Max. Number of Loading Images during Multi-input</i> in the <i>Vision System FH/FHV series User's Manual (Cat.No. Z365)</i> .					
Possible Number of Logging Images to Sensor Controller							
Possible Number of Scenes		128					
Operating on UI	USB Mouse	Yes (wired USB and driver is unnecessary type)					
	Touch Panel	Yes (RS-232C/USB connection: FH-MT12)					
Setup		Create the processing flow using Flow editing.					
Language		Japanese, English, Simplified Chinese, Traditional Chinese, Korean, German, French, Spanish, Italian, Vietnamese, Polish					
External Interface	Serial Communication		RS-232C x 1				
	Ethernet Communication	Protocol	Non-procedure (TCP/UDP)				
		I/F	1000BAS E-T x 1	1000BASE-T x 2		1000BAS E-T x 1	1000BASE-T x 2
	EtherNet/IP Communication		Yes (Target/Ethernet port)				
	PROFINET Communication		<ul style="list-style-type: none"> • Yes (Slave/Ethernet port) • Conformance class A 				
	EtherCAT Communication		Yes (slave)				
	Parallel I/O		12 inputs/31 outputs: Use 1 Line. Operation mode: Except Multi-line random-trigger mode. 17 inputs/37 outputs: Use 2 Line. Operation mode: Multi-line random-trigger mode. 14 inputs/29 outputs: Use 3 to 4 Line. Operation mode: Multi-line random-trigger mode. 19 inputs/34 outputs: Use 5 to 8 Line. Operation mode: Multi-line random-trigger mode.				

Series		FH-3000 Series			FH-1000 Series		
Type		Standard Controller(4 cores)			Standard Controller(2 cores)		
Model		FH-3050	FH-3050-10	FH-3050-20	FH-1050	FH-1050-10	FH-1050-20
	Encoder Interface	Input voltage: 5 V ± 5% Signal: RS-422A Line Driver Level Phase A/B/Z: 1 MHz					
	Monitor Interface	DVI-I output (Analog RGB & DVI-D single link) x 1					
	USB I/F	USB2.0 host x 4(BUS Power: 5 V/0.5 A per port)					
	SD Card I/F	SDHC x 1					
Indicator Lamps	Main	POWER: Green ERROR: Red RUN: Green ACCESS: Yellow					
	Ethernet	NET RUN: Green LINK/ ACT: Yel- low	NET RUN1: Green LINK/ACT1: Yellow NET RUN2: Green LINK/ACT2: Yellow	NET RUN: Green LINK/ ACT: Yel- low	NET RUN1: Green LINK/ACT1: Yellow NET RUN2: Green LINK/ACT2: Yellow		
	SD Card	SD POWER: Green SD BUSY: Yellow					
	EtherCAT	ECAT RUN: Green LINK/ACT IN: Green LINK/ACT OUT: Green ECAT ERR: Red					
Supply Voltage		20.4 VDC to 26.4 VDC					
Current consumption	<ul style="list-style-type: none"> When connecting an intelligent compact digital camera When connecting the following lighting or lighting controllers without an external power supply <ul style="list-style-type: none"> - FLV-TCC1 - FLV-TCC4 - FLV-TCC3HB - FLV-TCC1EP - FL-TCC1 When connecting the following lighting or lighting controllers <ul style="list-style-type: none"> - FL-TCC1PS - FL-MD□MC 	5.0A max.	7.0A max.	11.5A max.	4.7A max.	6.5A max.	10.9A max.
	Other than above	4.1A max.	4.8A max.	6.8A max.	3.6A max.	4.3A max.	6.2A max.
Built-in FAN		Yes					
Usage Environment	Ambient temperature range	Operating: 0°C to +50°C Storage: -20 to +65°C (with no icing or condensation)					

Series		FH-3000 Series			FH-1000 Series		
Type		Standard Controller(4 cores)			Standard Controller(2 cores)		
Model		FH-3050	FH-3050-10	FH-3050-20	FH-1050	FH-1050-10	FH-1050-20
Ambient humidity range		Operating and storage: 35 to 85% (with no condensation)					
Ambient atmosphere		No corrosive gases					
Vibration tolerance		Oscillation frequency: 10 to 150 Hz, Half amplitude: 0.1 mm, Acceleration: 15 m/s ² Sweep time: 8 minute/count, Sweep count: 10, Vibration direction: up and down/front and behind/left and right					
Shock resistance		Impact force: 150 m/s ² Test direction: up and down/front and behind/left and right					
Noise immunity	Fast Transient Burst	<ul style="list-style-type: none"> DC power: Direct infusion: 2 kV, Pulse rising: 5 ns, Pulse width: 50 ns, Burst continuation time: 15 ms/0.75 ms, Period: 300 ms, Application time: 1 min. I/O line: Direct infusion: 1 kV, Pulse rising: 5 ns, Pulse width: 50 ns, Burst continuation time: 15 ms/0.75 ms, Period: 300 ms, Application time: 1 min. 					
Grounding		Class D grounding (100 Ω or less grounding resistance) ^{*3}					
External Features	Dimensions	190 mm x 115 mm x 182.5 mm Note Height: Including the rubber at the base.					
	Weight	Approx. 3.2kg	Approx. 3.4kg	Approx. 3.4kg	Approx. 3.2kg	Approx. 3.4kg	Approx. 3.4kg
	Degree of protection	IEC60529 IP20					
	Case material	Cover: zinc-plated steel plate, Side plate: aluminum (A6063)					

*1. According to the CPU performance, FH-1000 series is recommended to use up to two lines in this mode.

*2. When the 12 megapixels camera: Max. 4 cameras are connectable. When use except 12 megapixels cameras: Max. 8 cameras are connectable.

*3. Existing the third class grounding

Component Names and Functions

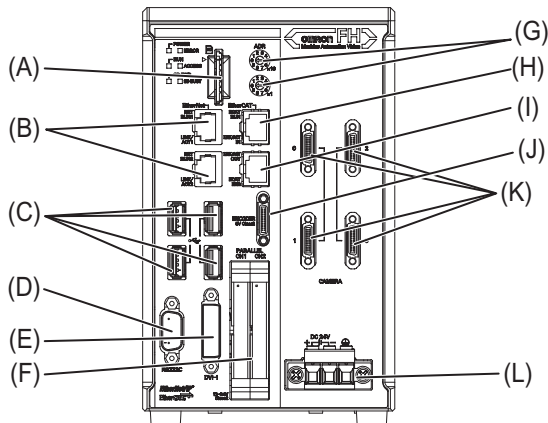

Connector name	Description				
(A) SD memory card installation connector	Install the SD memory card. Do not plug or unplug the SD memory card during measurement operation. Otherwise measurement time may be affected or data may be destroyed.				
(B) Ethernet connector	<p>Connect an Ethernet device.</p> <table border="1"> <tr> <td>FH-1050/FH-3050</td> <td>FH-1050-10/-20, FH-3050-10/-20 FH-2000/5000 series</td> </tr> <tr> <td> <p>Ethernet port, EtherNet/IP port, and PROFINET port are sharing use.</p> </td> <td> <p>Upper port : Ethernet port Lower port : Ethernet port, EtherNet/IP port, and PROFINET port are sharing use.</p> </td> </tr> </table>	FH-1050/FH-3050	FH-1050-10/-20, FH-3050-10/-20 FH-2000/5000 series	<p>Ethernet port, EtherNet/IP port, and PROFINET port are sharing use.</p>	<p>Upper port : Ethernet port Lower port : Ethernet port, EtherNet/IP port, and PROFINET port are sharing use.</p>
FH-1050/FH-3050	FH-1050-10/-20, FH-3050-10/-20 FH-2000/5000 series				
<p>Ethernet port, EtherNet/IP port, and PROFINET port are sharing use.</p>	<p>Upper port : Ethernet port Lower port : Ethernet port, EtherNet/IP port, and PROFINET port are sharing use.</p>				
(C) USB connector	<p>Connect a USB device.</p> <p>Do not plug or unplug it during measurement. Otherwise measurement time may be affected or data may be destroyed.</p> <table border="1"> <tr> <td>FH-1000/FH-3000 series</td> <td>FH-2000/FH-5000 series</td> </tr> <tr> <td> <p>All ports: USB2.0</p> </td> <td> <p>Left ports: USB2.0 Right ports: USB3.0</p> <p>USB3.0 interface is more capable of powering bus power than USB2.0. By combining USB3.0 devices, faster transmission than USB2.0 can be achieved.</p> </td> </tr> </table>	FH-1000/FH-3000 series	FH-2000/FH-5000 series	<p>All ports: USB2.0</p>	<p>Left ports: USB2.0 Right ports: USB3.0</p> <p>USB3.0 interface is more capable of powering bus power than USB2.0. By combining USB3.0 devices, faster transmission than USB2.0 can be achieved.</p>
FH-1000/FH-3000 series	FH-2000/FH-5000 series				
<p>All ports: USB2.0</p>	<p>Left ports: USB2.0 Right ports: USB3.0</p> <p>USB3.0 interface is more capable of powering bus power than USB2.0. By combining USB3.0 devices, faster transmission than USB2.0 can be achieved.</p>				
(D) RS-232C connector	Connect an external device such as a PLC.				
(E) DVI-I connector	Connect a monitor.				
(F) I/O (Parallel) connector (control lines, data lines)	Connect the controller to external devices such as a sync sensor and PLC.				
(G) EtherCAT address setup volume	Used to set a station address (00 to 99) as an EtherCAT communication device.				

	Connector name	Description
(H)	EtherCAT communication connector (IN)	Connect the opposed EtherCAT device.
(I)	EtherCAT communication connector (OUT)	Connect the opposed EtherCAT device.
(J)	Encoder connector	Connect an encoder.
(K)	Camera connector	Connect cameras.
(L)	Power supply terminal connector	Connect a DC power supply. Wire the FH Sensor Controller independently on other devices. Wire the ground line. Be sure to ground the FH Sensor Controller alone. Use an attachment power terminal (male) for installation. For details, refer to <i>5-3 Sensor Controller Installation</i> on page 5 - 5.

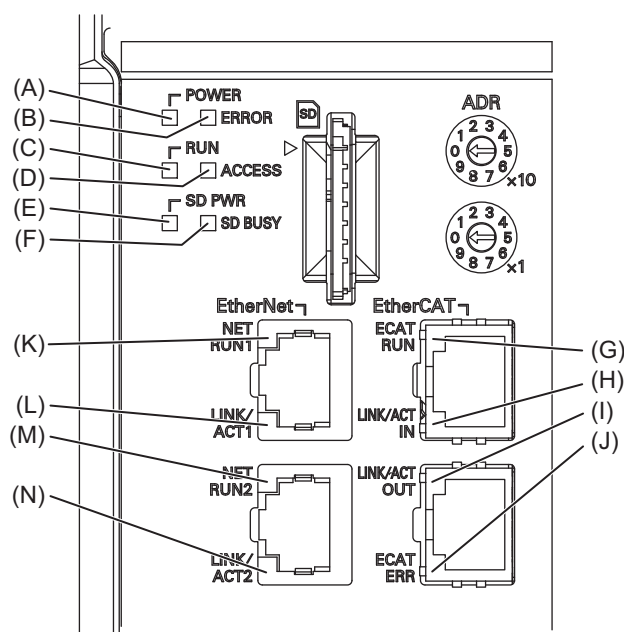

	LED name	Description
(A)	POWER LED	Lit while power is ON.
(B)	ERROR LED	Lit when an error has occurred.
(C)	RUN LED	Lit while the layout turned on output setting is displayed.
(D)	ACCESS LED	Blinks while the internal nonvolatile memory is accessed.
(E)	SD POWER LED	Lit while power is supplied to the SD memory card and the card is usable.
(F)	SD BUSY LED	Blinks while the SD memory card is accessed.
(G)	EtherCAT RUN LED	Lit while EtherCAT communications are usable.
(H)	EtherCAT LINK/ACT IN LED	Lit when connected with an EtherCAT device, and blinks while performing communications.
(I)	EtherCAT LINK/ACT OUT LED	Lit when connected with an EtherCAT device, and blinks while performing communications.
(J)	EtherCAT ERR LED	Lit when EtherCAT communications have become abnormal.

	LED name	Description
(K)	Ethernet NET RUN1 LED	Lit while Ethernet communications are usable.
(L)	Ethernet LINK/ACT1 LED	Lit when connected with an Ethernet device, and blinks while performing communications.
(M)	Ethernet NET RUN2 LED	Lit while Ethernet communications are usable.
(N)	Ethernet LINK/ACT2 LED	Lit when connected with an Ethernet device, and blinks while performing communications.

EtherCAT status indicator LED

Detailed LED specifications are given below.

LED name	Color	Status	Contents
ECAT RUN	Green	OFF	Initialization status
		Blinking	Pre-Operational status
		Single flash	Safe-Operational status
		ON	Operational status
ECAT ERROR	Red	OFF	No error
		Blinking	Communication setting error or PDO mapping error
		Single flash	Synchronization error or communications data error
		Double flash	Application WDT timeout
		ON	PDI WDT timeout
L/A IN	Green	OFF	Link not established in physical layer
		Flickering	In operation after establishing link
		ON	Link established in physical layer
L/A OUT	Green	OFF	Link not established in physical layer
		Flickering	In operation after establishing link
		ON	Link established in physical layer

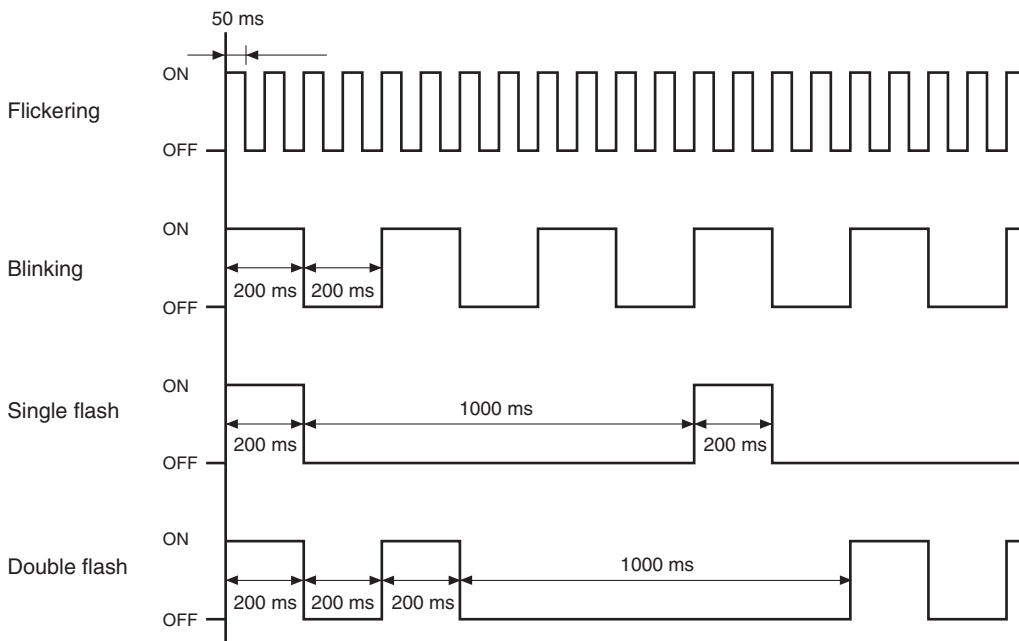

Dimensions

Sensor Controllers

FH-series Box-type

FH-5050/-5050-10/-5050-20

FH-3050/-3050-10/-3050-20

FH-2050/-2050-10/-2050-20

FH-1050/-1050-10/-1050-20

* The 2-camera type has only two camera connectors, and the 8-camera type has eight camera connectors.

* FH-1050 and FH-3050 have only one Ethernet connectors.

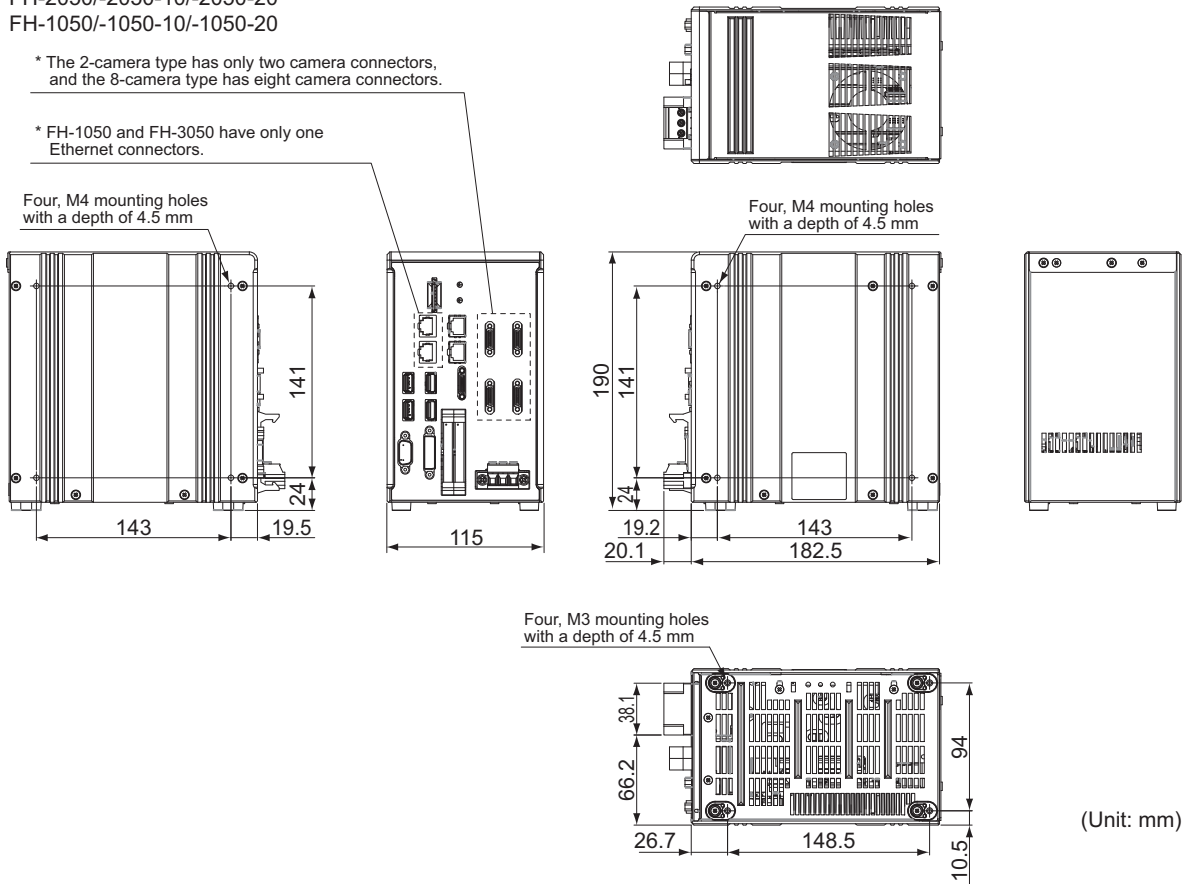

Additional Information

We have the 2D CAD data or 3D CAD data.

You can download CAD data from www.fa.omron.co.jp.

3-1-2 FH-L Series

Specification

Series		FH-L Series		
Type		Lite Controller		
Model		FH-L550	FH-L550-10	
Controller Type		Box type		
Parallel IO polarity		NPN/PNP (common)		
Main Functions	Operation Mode	Standard	Yes	
		Double Speed Multi-input	Yes	
		Non-stop adjustment mode	Yes	
		Multi-line random-trigger mode	No	
	Parallel Processing		Yes	
	Number of Connectable Camera		2	4
	Supported Camera	FH-S series camera	FH-S series cameras except FH-SM21R/SC21R are connectable.	
		FZ-S series camera	All of the FZ-S series cameras are connectable.	
	Camera I/F		OMRON I/F	
	Possible Number of Captured Images		Refer to <i>About Number of Logging Images</i> or <i>About Max. Number of Loading Images during Multi-input</i> in the <i>Vision System FH/FHV series User's Manual (Cat.No. Z365)</i> .	
	Possible Number of Logging Images to Sensor Controller			
	Possible Number of Scenes		128	
	Operating on UI	USB Mouse	Yes (wired USB and driver is unnecessary type)	
		Touch Panel	Yes (RS-232C/USB connection: FH-MT12)	
Setup		Create the processing flow using Flow editing.		
Language		Japanese, English, Simplified Chinese, Traditional Chinese, Korean, German, French, Spanish, Italian		
External Interface	Serial Communication		RS-232C x 1	
	Ethernet Communication	Protocol	Non-procedure (TCP/UDP)	
		I/F	1000BASE-T x 1	

Series		FH-L Series	
Type		Lite Controller	
Model		FH-L550	FH-L550-10
	EtherNet/IP Communication	Yes (Target/Ethernet port)	
	PROFINET Communication	<ul style="list-style-type: none"> • Yes (Slave/Ethernet port) • Conformance class A 	
	EtherCAT Communication	None	
	Parallel I/O	High-speed input: 1 Normal speed: 9 High-speed output: 4 Normal speed: 23	
	Encoder Interface	None	
	Monitor Interface	DVI-I output (Analog RGB & DVI-D single link) x 1	
	USB I/F	USB2.0 host x 1 (BUS Power: Port 5 V/0.5 A) USB3.0 host x 1 (BUS Power: Port 5 V/0.5 A)	
	SD Card I/F	SDHC x 1	
Indicator Lamps	Main	POWER: Green ERROR: Red RUN: Green ACCESS: Yellow	
	Ethernet	NET RUN: Green LINK/ACT: Yellow	
	SD Card	SD POWER: Green SD BUSY: Yellow	
	EtherCAT	None	
Supply Voltage		20.4 VDC to 26.4 VDC	
Current consumption	<ul style="list-style-type: none"> • When connecting an intelligent compact digital camera • When connecting the following lighting or lighting controllers without an external power supply <ul style="list-style-type: none"> - FLV-TCC1 - FLV-TCC4 - FLV-TCC3HB - FLV-TCC1EP - FL-TCC1 • When connecting the following lighting or lighting controllers <ul style="list-style-type: none"> - FL-TCC1PS - FL-MD□MC 	2.7A max.	4.4A max.
	Other than above	1.5A max.	2.0A max.
Built-in FAN		None	

Series		FH-L Series		
Type		Lite Controller		
Model		FH-L550	FH-L550-10	
Usage Environment	Ambient temperature range	Operating: 0°C to +55°C Storage: -25 to +70°C (with no icing or condensation)		
	Ambient humidity range	Operating and Storage: 10 to 90% (with no condensation)		
	Ambient atmosphere	No corrosive gases		
	Vibration tolerance	5 to 8.4 Hz with 3.5 mm amplitude, 8.4 to 150 Hz, acceleration of 9.8 m/s ² 100 min each in X, Y, and Z directions (10 sweeps of 10 min each = 100 min total)		
	Shock resistance	Impact force: 150 m/s ² Test direction: up and down/front and behind/left and right		
	Noise immunity	Fast Transient Burst	<ul style="list-style-type: none"> DC power: Direct infusion: 2 kV, Pulse rising: 5 ns, Pulse width: 50 ns, Burst continuation time: 15 ms/0.75 ms, Period: 300 ms, Application time: 1 min. I/O line: Direct infusion: 1 kV, Pulse rising: 5 ns, Pulse width: 50 ns, Burst continuation time: 15 ms/0.75 ms, Period: 300 ms, Application time: 1 min. 	
	Grounding		Class D grounding (100 Ω or less grounding resistance) ^{*1}	
External Features	Dimensions	200 mm x 80 mm x 130 mm		
	Weight	Approx. 1.5kg	Approx. 1.5kg	
	Degree of protection	IEC60529 IP20		
	Case material	PC		

*1. Existing the third class grounding

Component Names and Functions

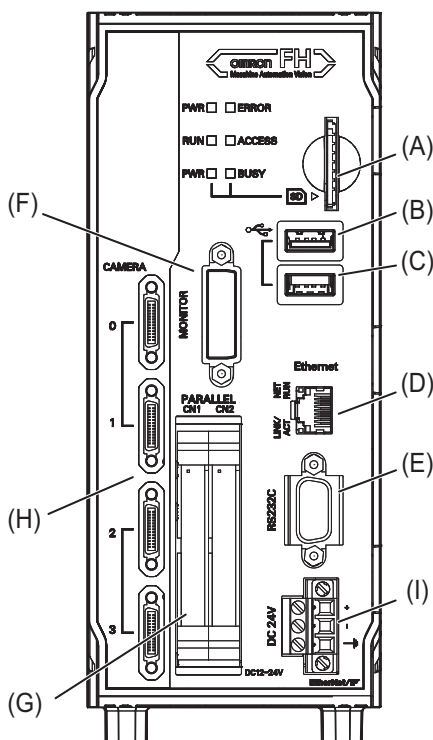

	Connector name	Description
(A)	SD memory card installation connector	Install the SD memory card. Do not plug or unplug the SD memory card during measurement operation. Otherwise measurement time may be affected or data may be destroyed.
(B)	USB2.0 connector	Connects to USB 2.0. Do not plug or unplug it during measurement. Otherwise measurement time may be affected or data may be destroyed.
(C)	USB3.0 connector	Connects to USB 3.0. Do not plug or unplug it during measurement. Otherwise measurement time may be affected or data may be destroyed.USB 3.0 has a high ability to supply the bus power. Use the Sensor Controller by combining USB 3.0, faster transport can be realized.
(D)	Ethernet connector	Connect an Ethernet device.Ethernet port, EtherNet/IP port, and PROFINET port are sharing use.
(E)	RS-232C connector	Connect an external device such as a PLC.
(F)	Monitor connector	Connect a monitor.
(G)	I/O (Parallel) connector (control lines, data lines)	Connect the controller to external devices such as a sync sensor and PLC.
(H)	Camera connector	Connect cameras.
(I)	Power supply terminal connector	Connect a DC power supply. Wire the FH Sensor Controller independently on other devices. Wire the ground line. Be sure to ground the FH Sensor Controller alone. Use an attachment power terminal (male) for installation. For details, refer to 5-3 <i>Sensor Controller Installation</i> on page 5 - 5.

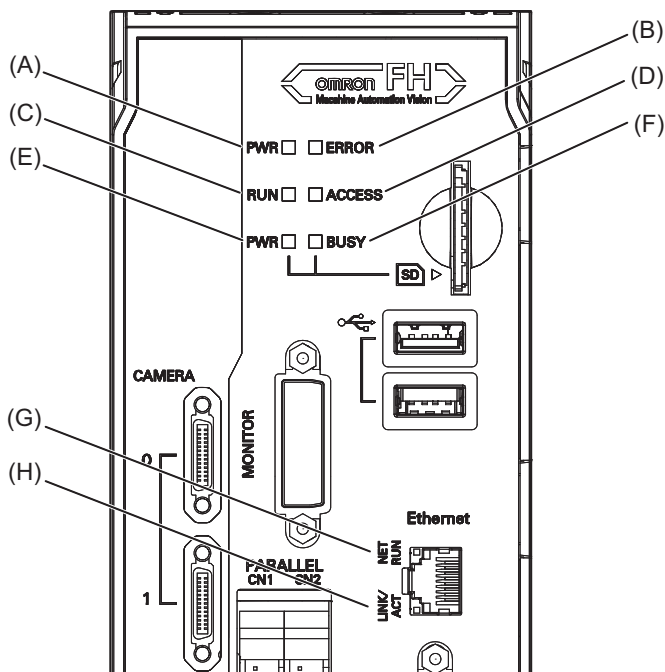

	LED name	Description
(A)	PWR LED	Lit while power is ON.
(B)	ERROR LED	Lit when an error has occurred.
(C)	RUN LED	Lit while the layout turned on output setting is displayed.
(D)	ACCESS LED	Blinks while the internal nonvolatile memory is accessed.
(E)	SD PWR LED	Lit while power is supplied to the SD memory card and the card is usable.
(F)	SD BUSY LED	Blinks while the SD memory card is accessed.

	LED name	Description
(G)	Ethernet NET RUN LED	Lit while Ethernet communications are usable.
(H)	Ethernet LINK/ACT LED	Lit when connected with an Ethernet device, and blinks while performing communications.

Dimensions

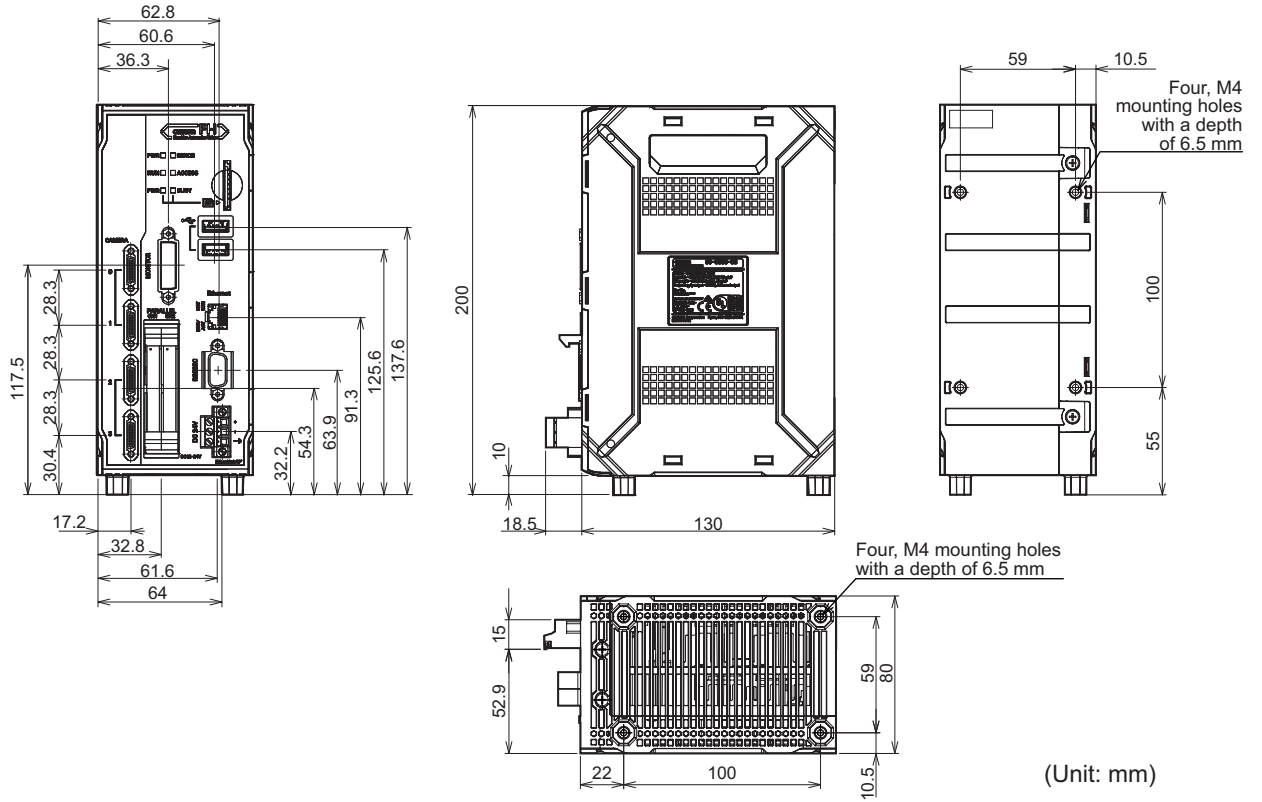

3-2 Camera

3-2-1 High-speed digital CMOS Camera (FH-S camera series)



Precautions for Safe Use

About connection of Sensor Controller and FH-SC12/FH-SM12 (12 megapixels camera).

- When you connect the Sensor Controller to the FH-SC12/FH-SM12, do not ground the positive terminal of 24 VDC power source. The internal circuit is possible to be given damage, it can be cause the failure.

Specification

Model	FH-SM	FH-SC	FH-SM02	FH-SC02
Image elements	CMOS image elements (1/3-inch equivalent)		CMOS image elements (2/3-inch equivalent)	
Color/Monochrome	Monochrome	Color	Monochrome	Color
Effective pixels	640 (H) x 480 (V)		2040 (H) x 1088 (V)	
Imaging area H x V (opposing corner)	4.8 x 3.6 (6.0 mm)		11.26 x 5.98 (12.76 mm)	
Pixel size	7.4 (μm) x 7.4 (μm)		5.5 (μm) x 5.5 (μm)	
Shutter function	Electronic shutter: Shutter speeds can be set from 20 μs to 100 ms.		Electronic shutter: Shutter speeds can be set from 25 μs to 100 ms.	
Partial function	1 to 480 lines	2 to 480 lines	1 to 1088 lines	2 to 2088 lines
Frame rate (Image Acquisition Time *1)	308 fps (3.3 ms)		219 fps (4.6 ms) *2	
Lens mounting	C mount			
Field of vision, installation distance	Selecting a lens according to the field of vision and installation distance			
Ambient temperature range	Operating: 0 to +40°C, Storage: -25 to +65°C (with no icing or condensation)			
Ambient humidity range	Operating and Storage: 35 to 85% (with no condensation)			
Weight	Approx. 105g		Approx. 110g	
Accessories	<ul style="list-style-type: none"> Instruction Sheet General Compliance Information and Instructions for EU 			

*1. This image acquisition time does not include the image conversion processing time of the sensor controller.

*2. Frame rate in high speed mode when the camera is connected using two camera cables.

Model	FH-SM04	FH-SC04	FH-SM12	FH-SC12
Image elements	CMOS image elements (1-inch equivalent)		CMOS image elements (1.76-inch equivalent)	
Color/Monochrome	Monochrome	Color	Monochrome	Color
Effective pixels	2040 (H) x 2048 (V)		4084 (H) x 3072 (V)	

Model	FH-SM04	FH-SC04	FH-SM12	FH-SC12
Imaging area H x V (opposing corner)	11.26 x 11.26 (15.93 mm)		22.5 x 16.9 (28.14 mm)	
Pixel size	5.5 (μm) x 5.5 (μm)		5.5 (μm) x 5.5 (μm)	
Shutter function	Electronic shutter: Shutter speeds can be set from 25 μs to 100 ms.		Electronic shutter: Shutter speeds can be set from 60 μs to 100 ms.	
Partial function	1 to 2048 lines	2 to 2048 lines	4 to 3072 lines (4-line increments)	
Frame rate (Image Acquisition Time * ¹)	118 fps (8.5 ms) * ²		38.9 fps (25.7 ms) * ²	
Lens mounting	C mount		M42 mount	
Field of vision, installation distance	Selecting a lens according to the field of vision and installation distance			
Ambient temperature range	Operating: 0 to +40°C, Storage: -25 to +65°C (with no icing or condensation)			
Ambient humidity range	Operating and Storage: 35 to 85% (with no condensation)			
Weight	Approx. 110g		Approx. 320g	
Accessories	<ul style="list-style-type: none"> • Instruction Sheet • General Compliance Information and Instructions for EU 			

*1. This image acquisition time does not include the image conversion processing time of the sensor controller.

*2. Frame rate in high speed mode when the camera is connected using two camera cables.

Model	FH-SMX	FH-SCX	FH-SMX05	FH-SCX05	FH-SMX12	FH-SCX12
Image elements	CMOS image elements (1/2.9-inch equivalent)		CMOS image elements (2/3-inch equivalent)		CMOS image elements (1.1-inch equivalent)	
Color/Monochrome	Mono-chrome	Color	Mono-chrome	Color	Mono-chrome	Color
Effective pixels	720 (H) x 540 (V)		2448 (H) x 2048 (V)		4092 (H) x 3000 (V)	
Imaging area H x V (opposing corner)	4.97 x 3.73 (6.21 mm)		8.45 x 7.07 (11.01 mm)		14.12 x 10.35 (17.50 mm)	
Pixel size	6.9 (μm) x 6.9 (μm)		3.45 (μm) x 3.45 (μm)		3.45 (μm) x 3.45 (μm)	
Shutter function	Electronic shutter: Shutter speeds can be set from 1 μs to 100 ms.		Electronic shutter: Shutter speeds can be set from 1 μs to 100 ms.		Electronic shutter: Shutter speeds can be set from 1.5 μs to 100 ms.	
Partial function	4 to 540 lines (4-line increments)		4 to 2048 lines (4-line increments)		4 to 3,072 lines (4-line increments)	
Frame rate (Image Acquisition Time * ¹)	523.6 fps (1.9 ms) * ²		97.2 fps (10.2 ms) * ³		40.1 fps (24.9 ms) * ³	
Lens mounting	C mount (Recommend 3Z4S-LE SV-V series)		C mount (Recommend 3Z4S-LE SV-H series)		C mount (Recommend 3Z4S-LE SV-LLD series)	
Field of vision, installation distance	Selecting a lens according to the field of vision and installation distance					
Ambient temperature range	Operating: 0 to +50°C, Storage: -25 to +65°C (with no icing or condensation)		Operating: 0 to +40°C, Storage: -25 to +65°C (with no icing or condensation)			
Ambient humidity range	Operating and Storage: 35 to 85% (with no condensation)					
Weight	Approx. 48g		Approx. 85g		Approx. 85g	

Model	FH-SMX	FH-SCX	FH-SMX05	FH-SCX05	FH-SMX12	FH-SCX12
Accessories	<ul style="list-style-type: none"> • Instruction Sheet • General Compliance Information and Instructions for EU 					

- *1. This image acquisition time does not include the image conversion processing time of the sensor controller.
- *2. Frame rate in high speed mode.
- *3. Frame rate in high speed mode when the camera is connected using two camera cables.

Image-Acquisition Time*1

Model		FH-SM02/FH-SC02	FH-SM04/FH-SC04	FH-SM12/FH-SC12	FH-SMX/FH-SCX	FH-SMX05/FH-SCX05	FH-SMX12/FH-SCX12	FH-SM21R/FH-SC21R
2 Cables*2	High Speed Mode*3	4.6 ms	8.5 ms	25.7 ms	-	10.3 ms	24.9 ms	42.6 ms
	Standard Mode	9.7 ms	17.9 ms	51.3 ms	-	22.1 ms	53.5 ms	90.1 ms
1 Cable	High Speed Mode*3	9.2 ms	17.0 ms	51.3 ms	1.9 ms	20.6 ms	50.0 ms	83.3 ms
	Standard Mode	19.3 ms	35.8 ms	102.0 ms	3.8 ms	44.1 ms	106.4 ms	175.4 ms

- *1. This image acquisition time does not include the image conversion processing time of the sensor controller.
- *2. Two Camera ports of the controller are used per one camera.
- *3. Up to 5 m Camera Cable length.

Dimensions

● **0.3 Megapixels Camera: FH-SC/-SM**

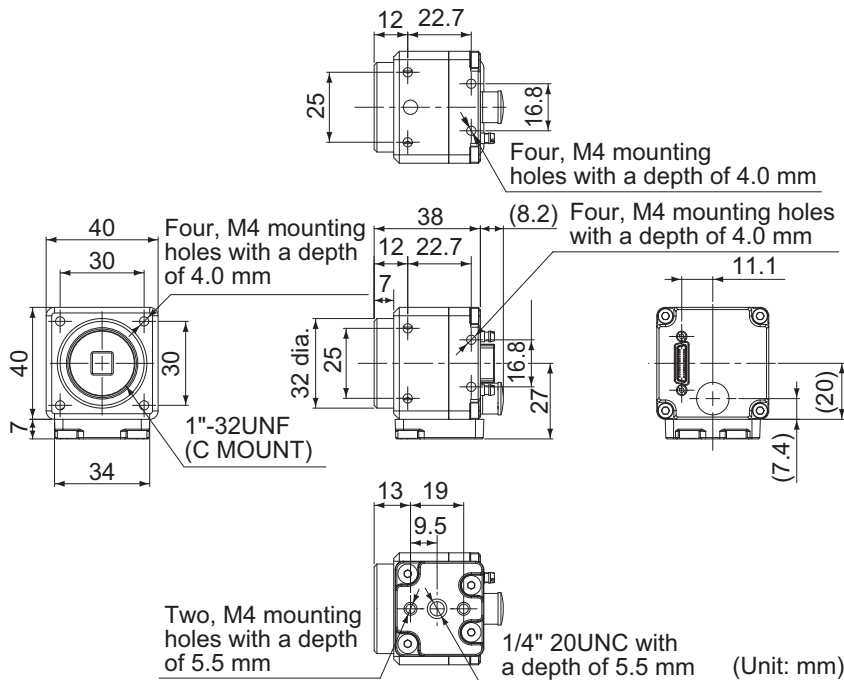

● 0.4 Megapixels Camera: FH-SCX/-SMX

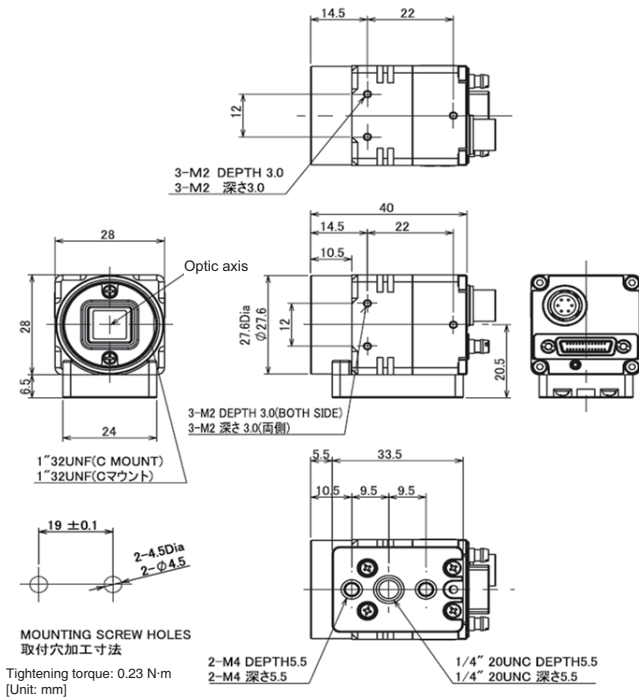

● 2 Megapixels Camera: FH-SC02/-SM02 and 4 Megapixels Camera: FH-SC04/-SM04

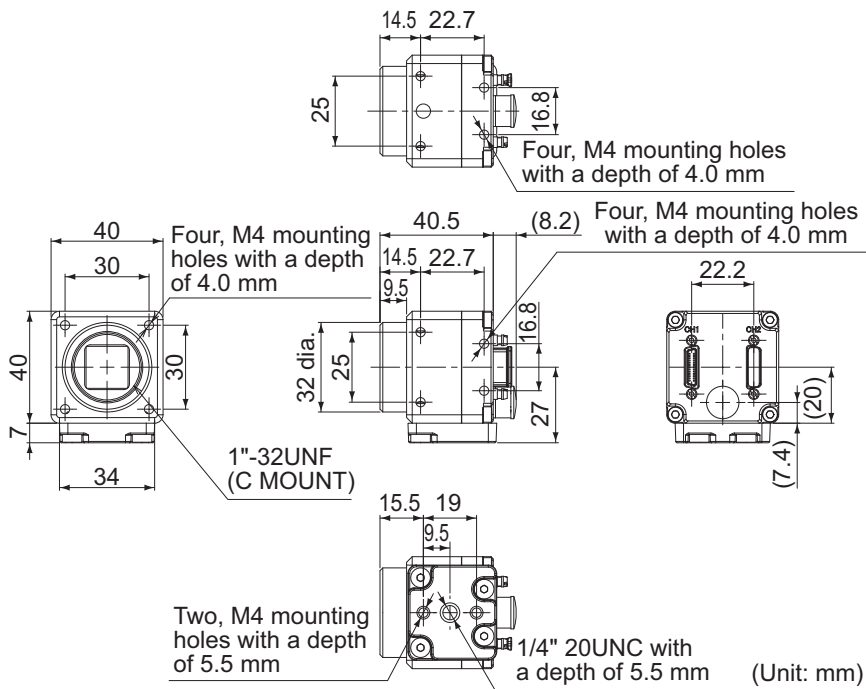

3-2-2 Digital CMOS Camera

Specification

Model	FH-SM05R	FH-SC05R	FH-SM21R	FH-SC21R	FZ-S5M3	FZ-SC5M3
Image elements	CMOS image elements (1/2.5-inch equivalent)		CMOS image elements (1-inch equivalent)		CMOS image elements (2/3-inch equivalent)	
Color/Monochrome	Mono-chrome	Color	Mono-chrome	Color	Mono-chrome	Color
Effective pixels	2592 (H) x 1944 (V)		5544 (H) x 3692 (V)		2488 (H) x 2048 (V)	
Imaging area H x V (opposing corner)	5.70 x 4.28 (7.13 mm)		13.31 x 8.86 (16 mm)		8.4 x 7.1 (11 mm)	
Pixel size	2.2 (μm) x 2.2 (μm)		2.4 (μm) x 2.4 (μm)		3.45 (μm) x 3.45 (μm)	
Scan Type	Progressive					
Shutter Method	Rolling shutter					
Shutter function	Electronic shutter: Electronic shutter; Shutter speeds can be set from 500 μs to 100 ms in multiples of 50 μs.		Electronic shutter: Shutter speeds can be set from 50 μs to 100 ms. *1		Electronic shutter: Shutter speeds can be set from 20 μs to 100 ms.	
Partial function	4 to 1944 lines (2-line increments)		1848 to 3692 lines		4 to 2048 lines	
Frame rate (Image Acquisition Time*2)	14 fps (71.7 ms)		23.5 fps (42.6 ms)		25.6 fps (38.2 ms)	
Lens mounting	C mount		C mount (Recommend 3Z4S-LE SV-LLD series)		C mount (Recommend 3Z4S-LE SV-H series)	
Field of vision, installation distance	Selecting a lens according to the field of vision and installation distance					
Ambient temperature range	Operating: 0 to +40°C, Storage: -30 to +65°C (with no icing or condensation)				Operating: 0 to +40°C, Storage: -25 to +65°C (with no icing or condensation)	
Ambient humidity range	Operating and Storage: 35 to 85% (with no condensation)					
Weight	Approx. 52g		Approx. 85g (w/base)		Approx. 85g (w/base)	
Accessories	<ul style="list-style-type: none"> • Instruction Sheet • General Compliance Information and Instructions for EU 					

*1. When using FH-S□21R in the reset mode and rolling shutter, the actual shutter speed is rounded to the following values for the screen set values and reflected to the real operation.

Note that the reflecting method depends on the number of cables and communication speed setting.

Camera cable: 1, Communication speed: Standard: A multiple of 46.9 μs

Camera cable: 1, Communication speed: High-speed: A multiple of 22.3 μs

Camera cable: 2, Communication speed: Standard: A multiple of 23.5 μs

Camera cable: 2, Communication speed: High-speed: A multiple of 11.2 μs

For example, the actual shutter speed is below when the shutter speed is set to 2,000 μs.

Camera cable: 1, Communication speed: Standard: 1,969.8 μs (42 times of 46.9 μs)

Camera cable: 1, Communication speed: High-speed: 1,984.7 μs (89 times of 22.3 μs)

Camera cable: 2, Communication speed: Standard: 1,997.5 μs (85 times of 23.5 μs)

Camera cable: 2, Communication speed: High-speed: 1,993.6 μs (178 times of 11.2 μs)

*2. This image acquisition time does not include the image conversion processing time of the sensor controller.

Dimensions

● 5 Megapixels Camera: FH-SM05R/-SC05R

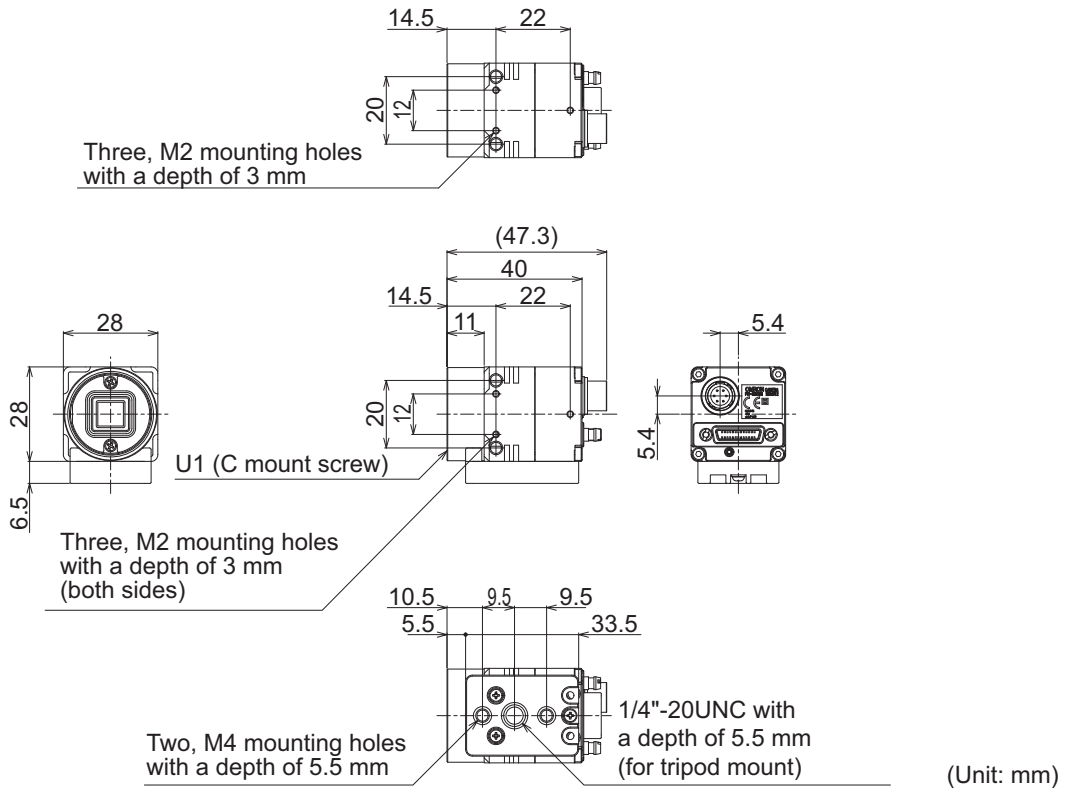

● 5 Megapixels Camera: FZ-S5M3/-SC5M3

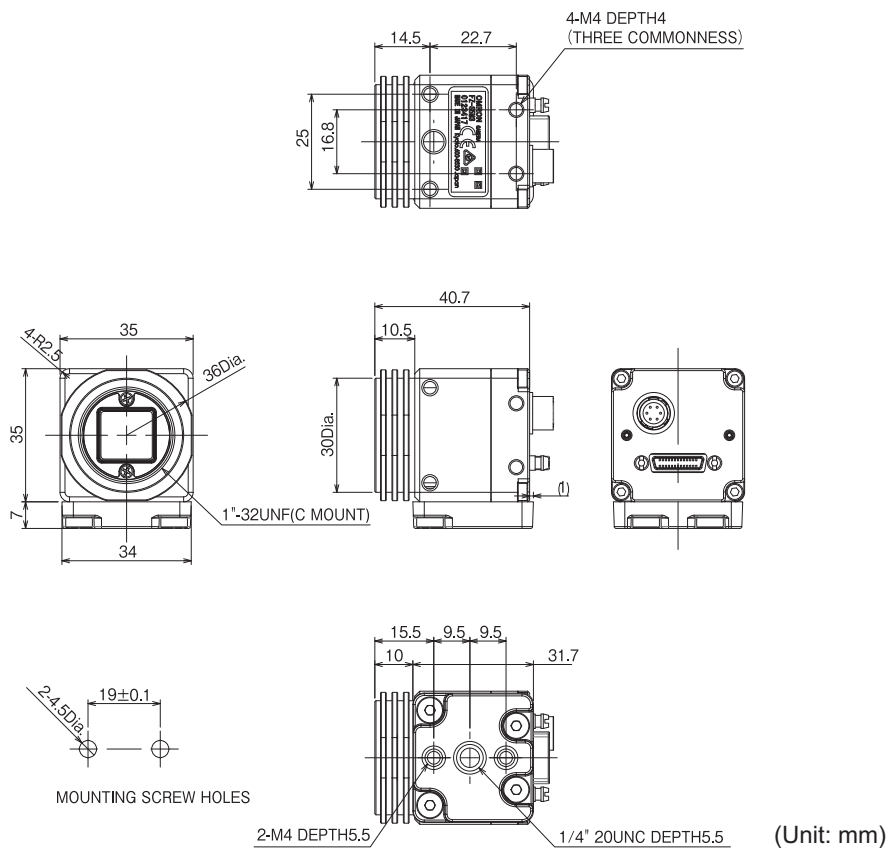

● 20.4 Megapixels Camera: FH-SM21R/FH-SC21R

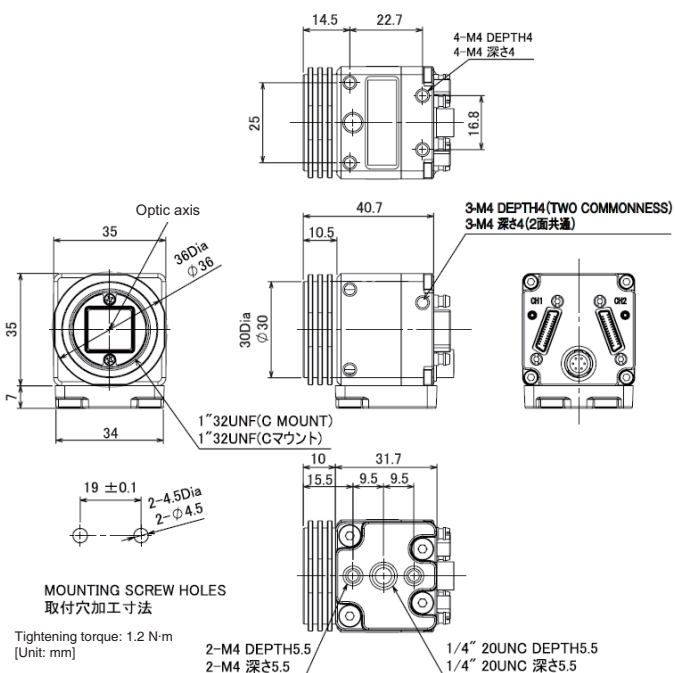

Additional Information

We have the 2D CAD data or 3D CAD data.
You can download CAD data from www.fa.omron.co.jp.

3-2-3 Digital CCD Camera: FZ-S Camera Series

Specification

Model	FZ-S	FZ-SC	FZ-S2M	FZ-SC2M	FZ-S5M2	FZ-SC5M2
Image elements	Interline transfer reading all pixels, CCD image elements (1/3-inch equivalent)		Interline transfer reading all pixels, CCD image elements (1/1.8-inch equivalent)		Interline transfer reading all pixels, CCD image elements (2/3-inch equivalent)	
Color/Monochrome	Mono-chrome	Color	Mono-chrome	Color	Mono-chrome	Color
Effective pixels	640 (H) x 480 (V)		1600 (H) x 1200 (V)		2448 (H) x 2044 (V)	
Imaging area H x V (opposing corner)	4.8 x 3.6 (6 mm)		7.1 x 5.4 (8.9 mm)		8.4 x 7.1 (11 mm)	
Pixel size	7.4 (μm) x 7.4 (μm)		4.4 (μm) x 4.4 (μm)		3.45 (μm) x 3.45 (μm)	
Shutter function	Electronic shutter: Shutter speeds can be set from 20 μs to 100 ms.					
Partial function	12 to 480 lines		12 to 1200 lines		12 to 2044 lines	
Frame rate (Image Acquisition Time ^{*1})	80 fps (12.5 ms)		30 fps (33.3 ms)		16 fps (62.5 ms)	
Lens mounting	C mount					
Field of vision, installation distance	Selecting a lens according to the field of vision and installation distance					
Ambient temperature range	Operating: 0 to +50°C, Storage: -25 to +65°C (with no icing or condensation)		Operating: 0 to +40°C, Storage: -25 to +65°C (with no icing or condensation)		Operating: 0 to +40°C, Storage: -25 to +65°C (with no icing or condensation)	
Ambient humidity range	Operating and Storage: 35 to 85% (with no condensation)					
Weight	Approx. 55g		Approx. 76g		Approx. 140g	
Accessories	<ul style="list-style-type: none"> • Instruction Sheet • General Compliance Information and Instructions for EU 					

*1. This image acquisition time does not include the image conversion processing time of the sensor controller.

Dimensions

● **0.3 Megapixels Camera: FZ-S/-SC**

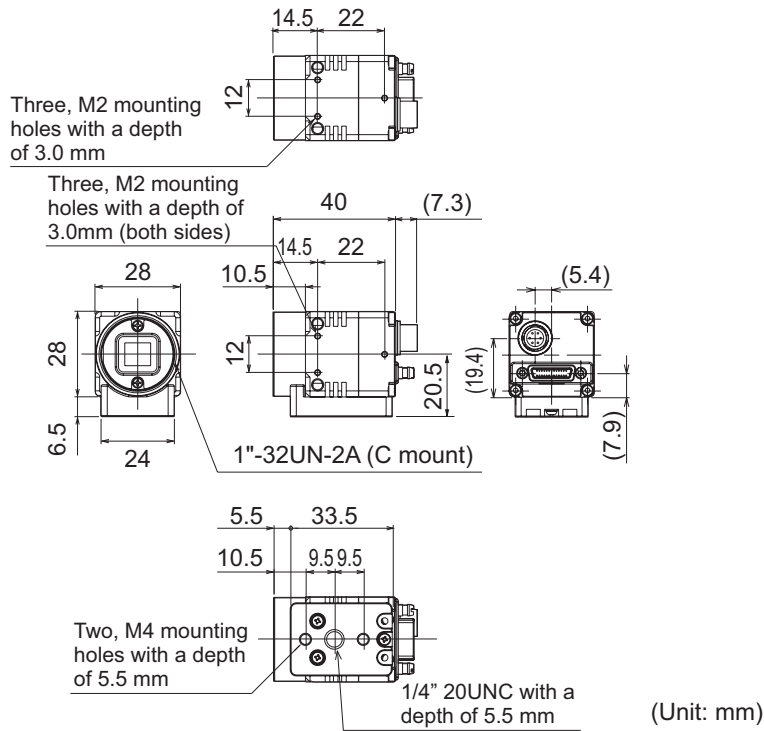

● **2 Megapixels Camera: FZ-S2M/-SC2M**

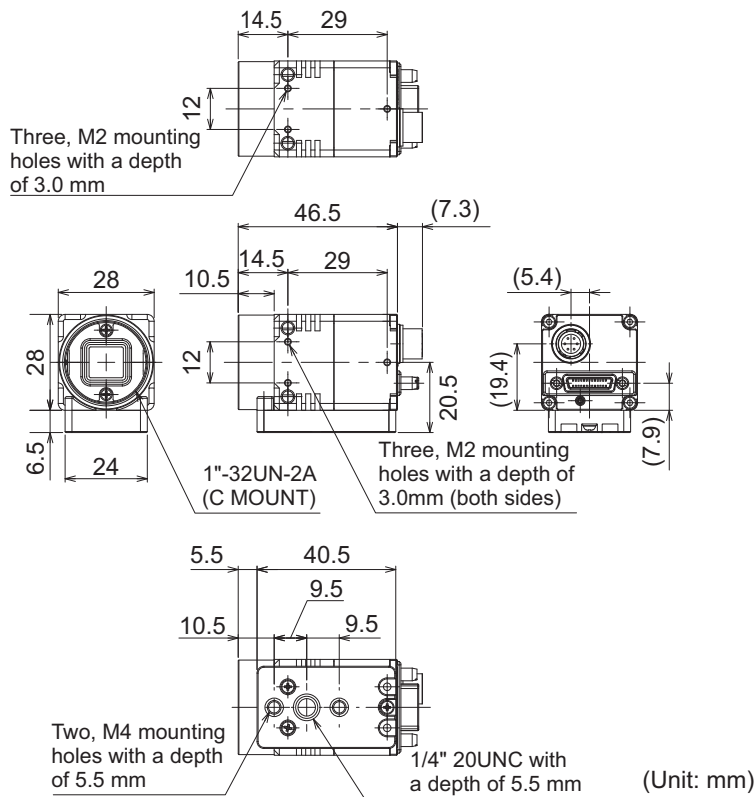

● 5 Megapixels Camera: FZ-S5M2/-SC5M2

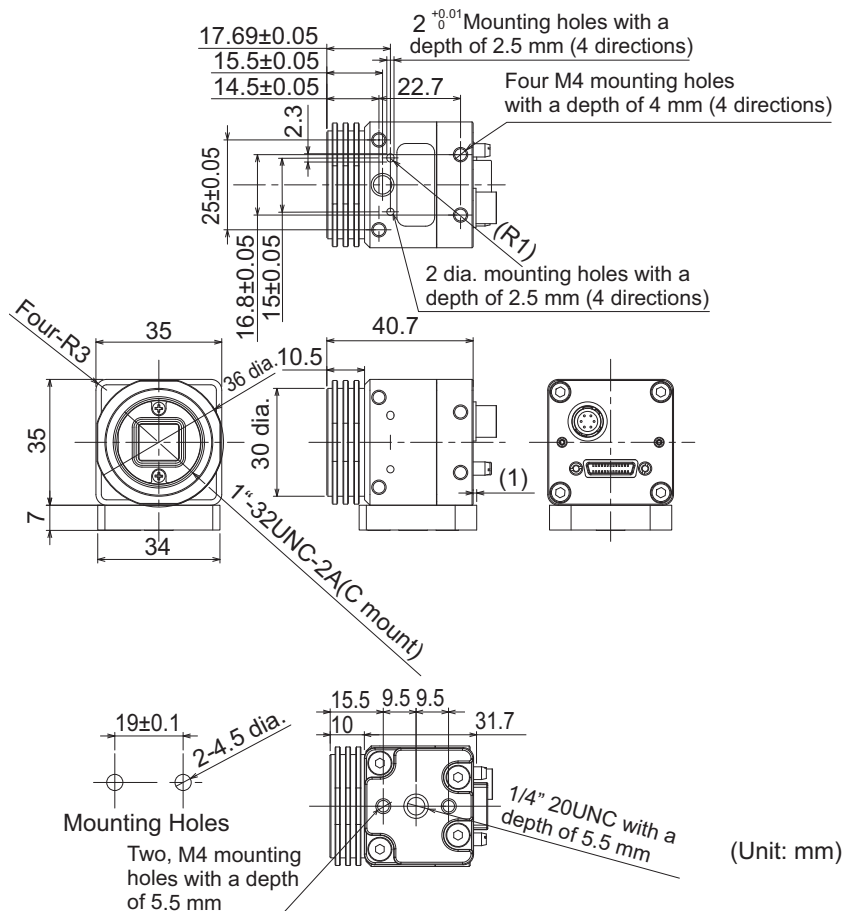

Additional Information

We have the 2D CAD data or 3D CAD data.
You can download CAD data from www.fa.omron.co.jp.

3-2-4 High-speed Digital CCD Camera: FZ-SH Camera Series

Specification

Model	FZ-SH	FZ-SHC
Image elements	Interline transfer reading all pixels, CCD image elements (1/3-inch equivalent)	
Color/Monochrome	Monochrome	Color
Effective pixels	640 (H) x 480 (V)	
Imaging area H x V (opposing corner)	4.8 x 3.6 (6 mm)	
Pixel size	7.4 (μm) x 7.4 (μm)	
Shutter function	Electronic shutter: Electronic shutter: select shutter speeds from 1/10 to 1/50,000 s.	
Partial function	12 to 480 lines	
Frame rate (Image Acquisition Time *1)	204 fps (4.9 ms)	

Model	FZ-SH	FZ-SHC
Field of vision, installation distance	Selecting a lens according to the field of vision and installation distance	
Ambient temperature range	Operating: 0 to +40°C, Storage: -25 to +65°C (with no icing or condensation)	
Ambient humidity range	Operating and Storage: 35 to 85% (with no condensation)	
Weight	Approx. 105g	
Accessories	<ul style="list-style-type: none"> • Instruction Sheet • General Compliance Information and Instructions for EU 	

*1. This image acquisition time does not include the image conversion processing time of the sensor controller.

Dimensions

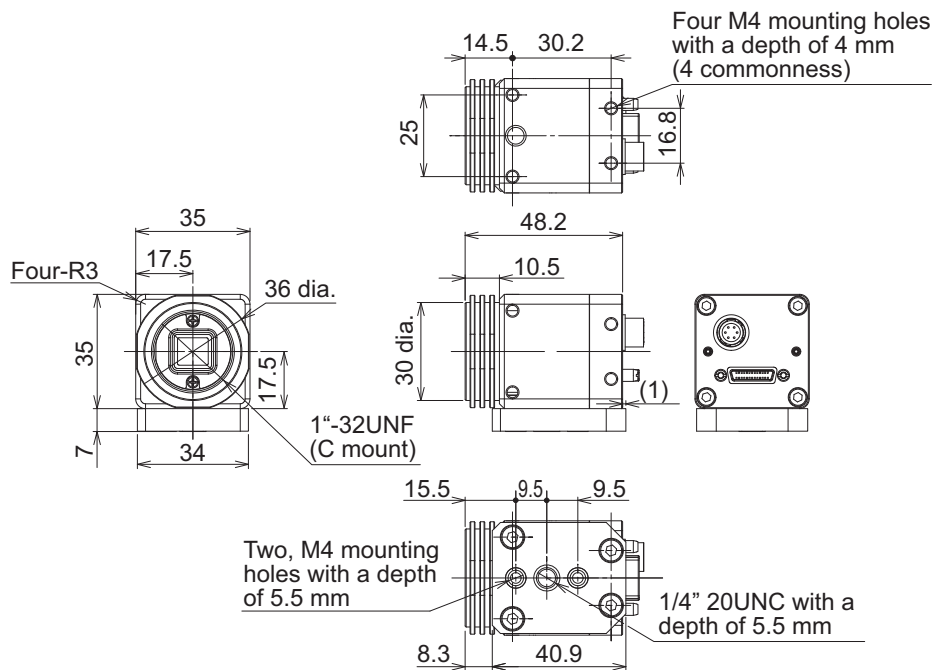

Additional Information

We have the 2D CAD data or 3D CAD data.
You can download CAD data from www.fa.omron.co.jp.

3-2-5 Small Digital CCD Cameras: FZ-S Camera Series

Specification

Model	FZ-SF	FZ-SFC	FZ-SP	FZ-SPC
Image elements	Interline transfer reading all pixels, CCD image elements (1/3-inch equivalent)			
Color/Monochrome	Monochrome	Color	Monochrome	Color
Effective pixels	640 (H) x 480 (V)			

Model	FZ-SF	FZ-SFC	FZ-SP	FZ-SPC
Imaging area H x V (opposing corner)	4.8 x 3.6 (6 mm)			
Pixel size	7.4 (μm) x 7.4 (μm)			
Shutter function	Electronic shutter: Shutter speeds can be set from 20 μs to 100 ms.			
Partial function	12 to 480 lines			
Frame rate (Image Acquisition Time ^{*1})	80 fps (12.5 ms)			
Lens mounting	Special mount (M10.5 P0.5)			
Field of vision, installation distance	Selecting a lens according to the field of vision and installation distance			
Ambient temperature range	Operating of camera amp: 0 to +50°C, Operating of camera head: 0 to +45°C Storage: -25 to +65°C (with no icing or condensation)			
Ambient humidity range	Operating and Storage: 35 to 85% (with no condensation)			
Minimum bending radius between camera head and camera amplifier	12.7 mm			
Weight	Approx. 150gApprox. 150g			
Accessories	<ul style="list-style-type: none"> • Instruction Sheet • General Compliance Information and Instructions for EU • installation bracket • Four mounting screws (M2 x 4) 		<ul style="list-style-type: none"> • Instruction Sheet • General Compliance Information and Instructions for EU 	

*1. This image acquisition time does not include the image conversion processing time of the sensor controller.

Dimensions

● Camera Head

a) Flat Camera: FZ-SF/-SFC

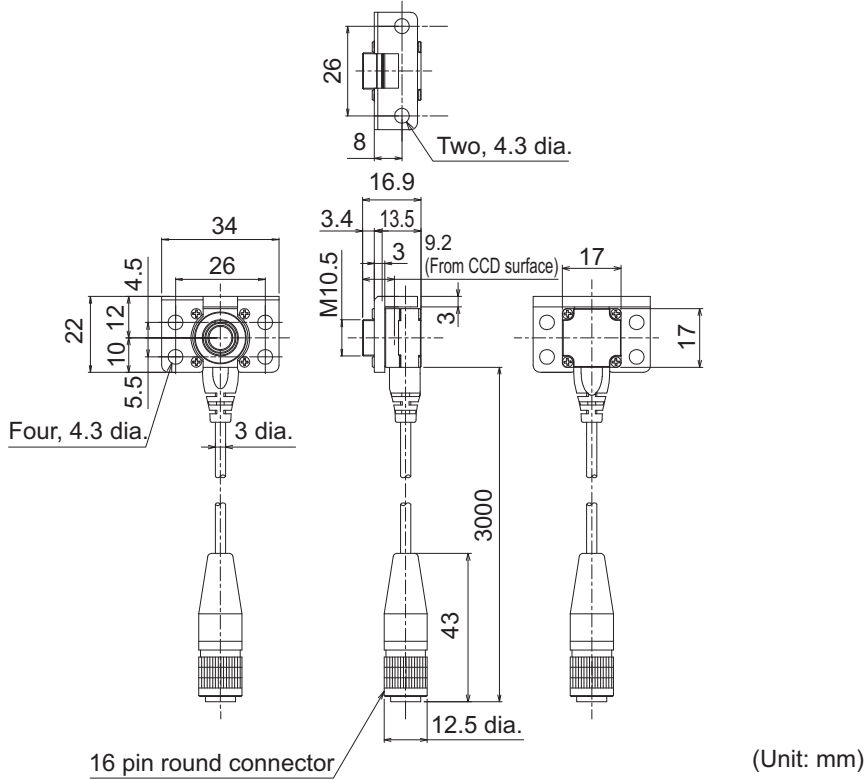

b) Pen-shaped Camera: FZ-SP/-SPC

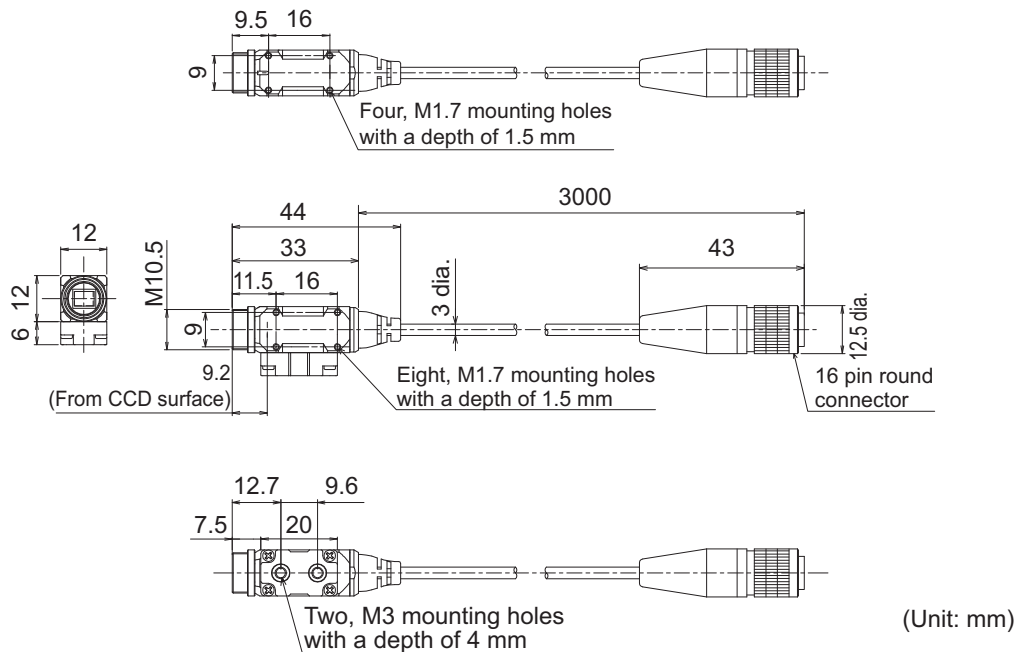

● Camera Amplifier

Flat Camera, Pen-shaped Camera

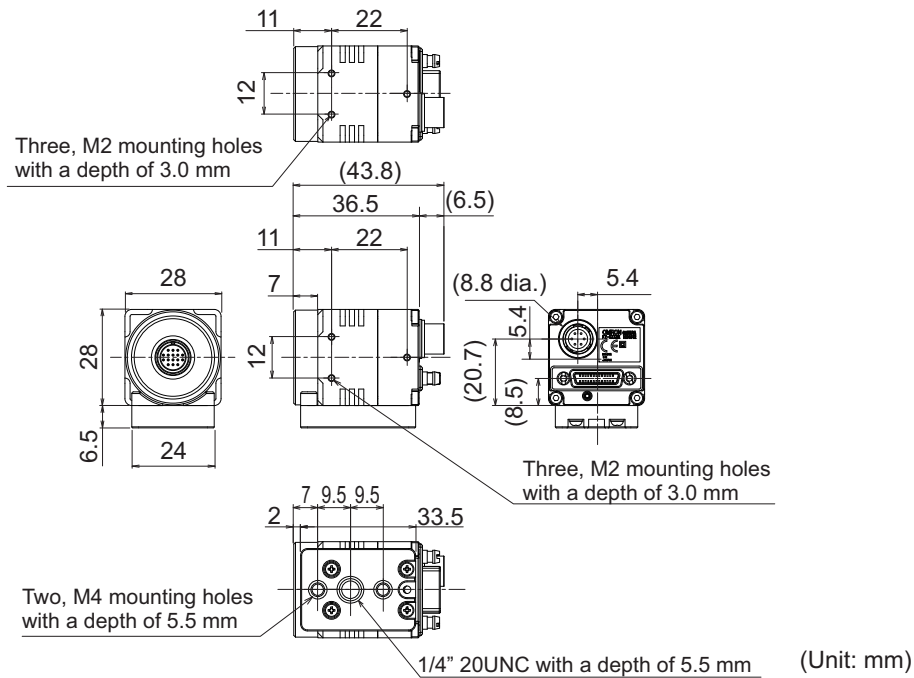

Additional Information

We have the 2D CAD data or 3D CAD data.
You can download CAD data from www.fa.omron.co.jp.

3-2-6 Intelligent Compact Digital CMOS Camera: FZ-S camera Series

Specification

Model	FZ-SQ010F	FZ-SQ050F	FZ-SQ100F	FZ-SQ100N
Image elements	CMOS color image elements (1/3-inch equivalent)			
Color/Monochrome	Color			
Effective pixels	752 (H) x 480 (V)			
Imaging area H x V (opposing corner)	4.51 x 2.88 (5.35 mm)			
Pixel size	6.0 (μm) x 6.0 (μm)			
Shutter function	1/250 to 1/32258			
Partial function	8 to 480 lines			
Frame rate (Image Acquisition Time*1)	60 fps (16.7 ms)			
Field of vision	7.5 x 4.7 to 13 x 8.2 mm	13 x 8.2 to 53 x 33 mm	53 x 33 to 240 x 153 mm	29 x 18 to 300 x 191 mm
Installation distance	38 to 60 mm	56 to 215 mm	220 to 970 mm	32 to 380 mm
LED class *2	Risk Group2			
Ambient temperature range	Operating: 0 to +50°C, Storage: -25 to +65°C			
Ambient humidity range	Operating and Storage: 35 to 85% (with no condensation)			
Weight	Approx. 150g		Approx. 140g	

Model	FZ-SQ010F	FZ-SQ050F	FZ-SQ100F	FZ-SQ100N
Accessories	Mounting bracket (FQ-XL), Polarizing filter attachment (FQ-XF1), Instruction Sheet, Warning label			

*1. This image acquisition time does not include the image conversion processing time of the sensor controller.

*2. Applicable standards: IEC62471-2

Dimensions

● Narrow view: FZ-SQ010F and Standard view: FZ-SQ050F

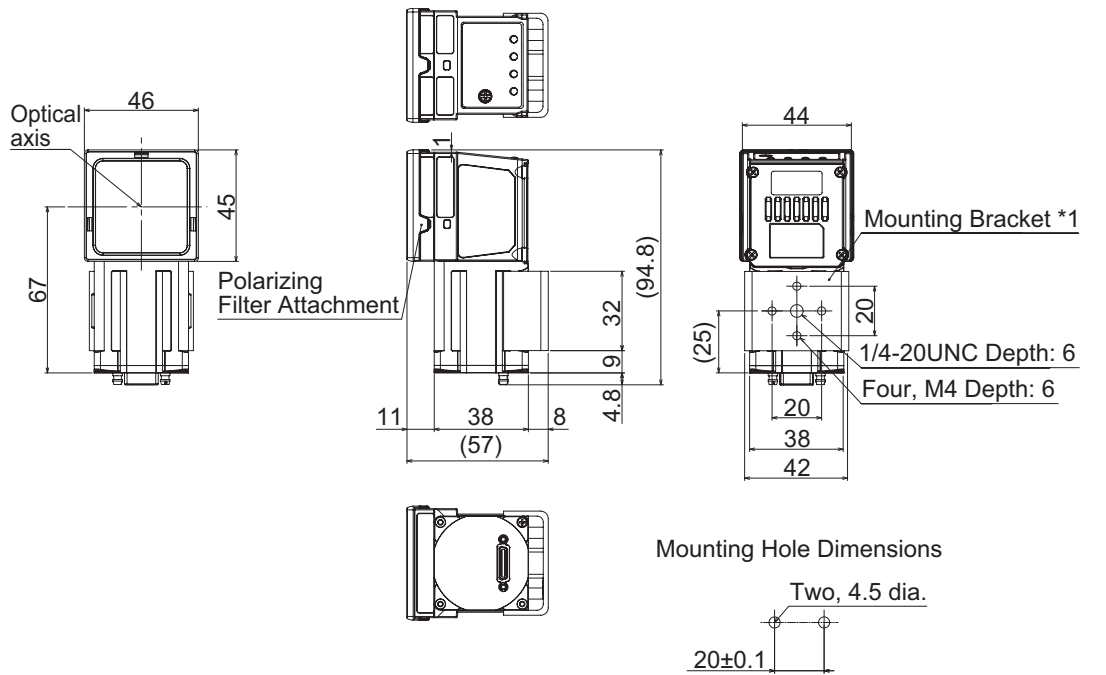

Tightening torque: 1.2 N·m (Unit: mm)

*1. The mounting brackets can be connected to either side.

● Wide View

- Long-distance: FZ-SQ100F
- Short-distance: FZ-SQ100N

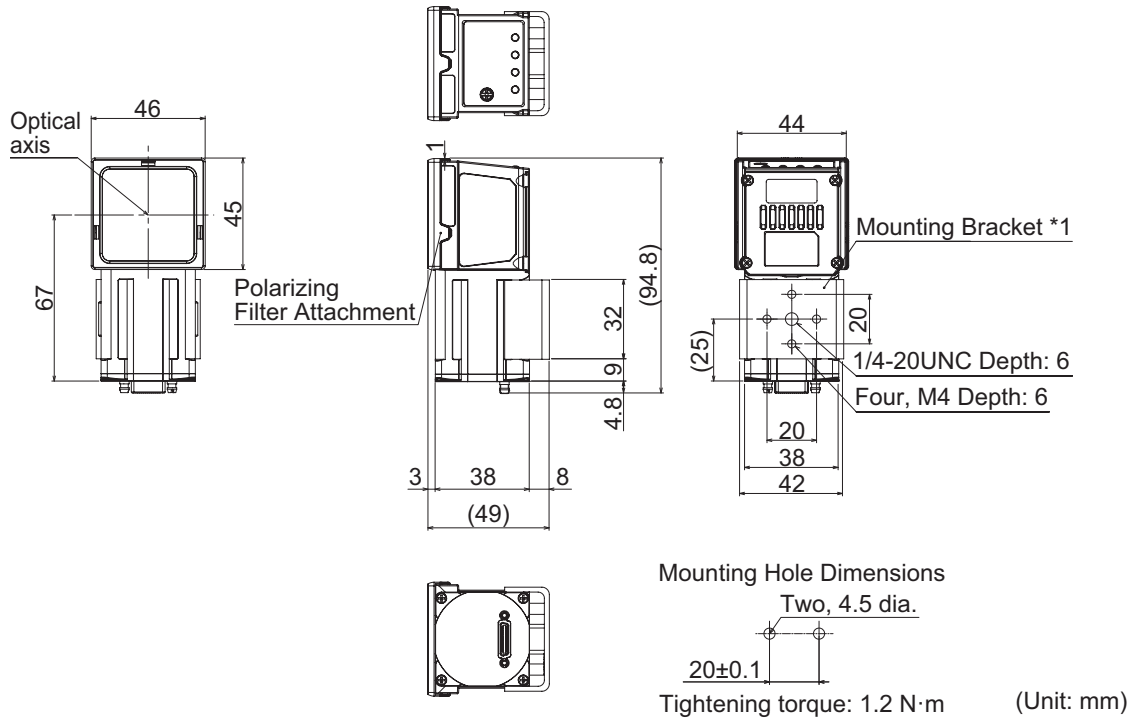

*1. The mounting brackets can be connected to either side.



Additional Information

We have the 2D CAD data or 3D CAD data.
 You can download CAD data from www.fa.omron.co.jp.

3-3 Camera Cable

3-3-1 Camera Cable and Right-angle Camera Cable

Specification

Model	FZ-VS3 (2m)	FZ-VSL3 (2m)
Vibration (resistance)	10 to 150 Hz, Single amplitude 0.15 mm, 3 directions, 8 strokes, 4 times	
Ambient temperature range	Operation and storage: 0 to +65°C (with no icing or condensation)	
Ambient humidity range	Operation and storage: 40 to 70% (with no condensation)	
Ambient atmosphere	No corrosive gases	
Material	Cable sheath, connector: PVC	
Minimum bending radius	69 mm	
Weight	Approx. 170g	

Dimensions

● Camera Cable: FZ-VS3

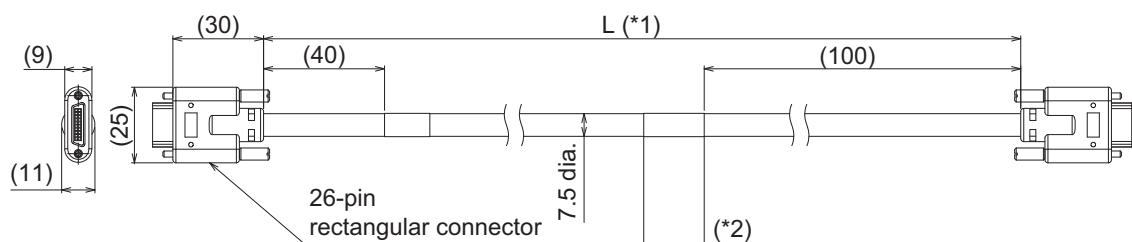

*1. Cable is available in 2 m/3 m/5 m/10 m.

*2. Each camera cables has polarity. Please ensure that the name plate side of the cable is connected to the controller.

(Unit: mm)

● Right-angle Camera Cable: FZ-VSL3

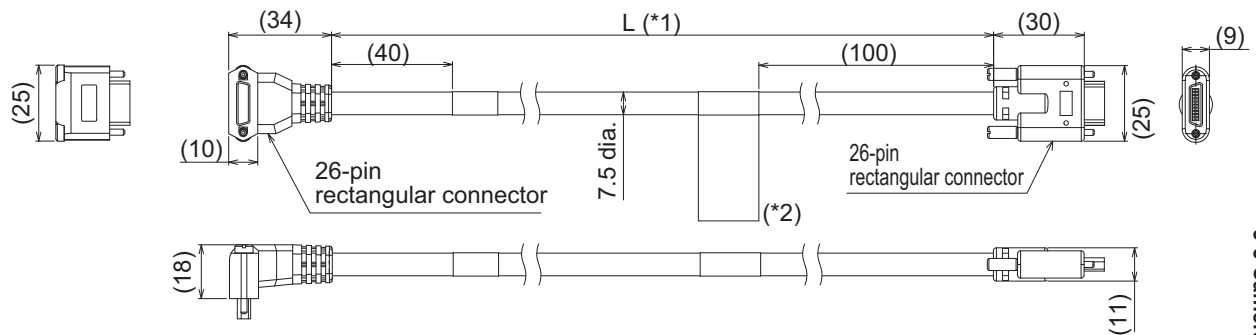

*1. Cable is available in 2 m/3 m/5 m/10 m.

*2. Each camera cables has polarity. Please ensure that the name plate side of the cable is connected to the controller.

(Unit: mm)



Additional Information

We have the 2D CAD data or 3D CAD data.
You can download CAD data from www.fa.omron.co.jp.

3-3-2 Bend resistant Camera Cable and Bend resistant Right-angle Camera Cable

Specification

Model	FZ-VSB3 (2m)	FZ-VSLB3 (2m)
Vibration (resistance)	10 to 150 Hz, Single amplitude 0.15 mm, 3 directions, 8 strokes, 4 times	
Ambient temperature range	Operation and storage: 0 to +65°C (with no icing or condensation)	
Ambient humidity range	Operation and storage: 40 to 70% (with no condensation)	
Ambient atmosphere	No corrosive gases	
Material	Cable sheath, connector: PVC	
Minimum bending radius	69 mm	
Bend performance *1	U-bend flexing: 1 million times or more, Bending radius: 50 mm, Stroke: 300 mm, Speed: 30/minute	
Weight	Approx. 180g	

*1. This data values are for reference only and not guaranteed values.

Dimensions

● Bend resistant Camera Cable: FZ-VSB3

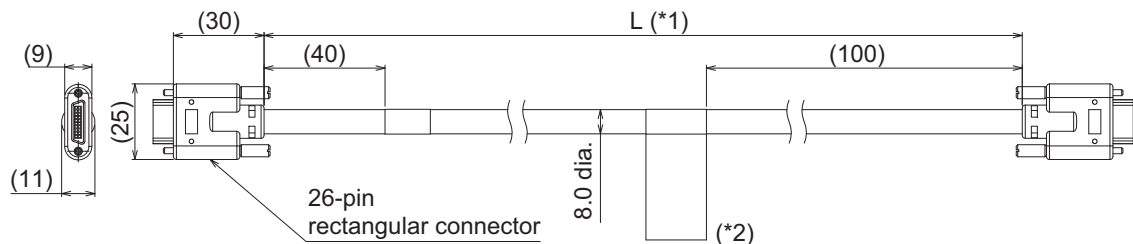

*1. Cable is available in 2 m/3 m/5 m/10 m.

*2. Each camera cables has polarity. Please ensure that the name plate side of the cable is connected to the controller.

(Unit: mm)

● Bend resistant Right-angle Camera Cable: FZ-VSLB3

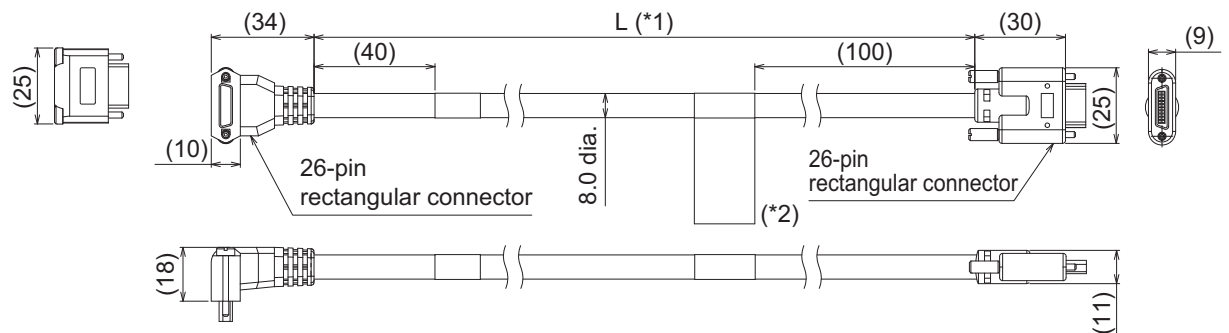

*1. Cable is available in 2 m/3 m/5 m/10 m.

*2. Each camera cables has polarity. Please ensure that the name plate side of the cable is connected to the controller.

(Unit: mm)



Additional Information

We have the 2D CAD data or 3D CAD data.
You can download CAD data from www.fa.omron.co.jp.

3-3-3 Long-distance Camera Cable and Long-distance Right-angle Camera Cable

Specification

Model	FZ-VS4 (15m)	FZ-VSL4 (15m)
Vibration (resistance)	10 to 150 Hz, Single amplitude 0.15 mm, 3 directions, 8 strokes, 4 times	
Ambient temperature range	Operation and storage: 0 to +65°C (with no icing or condensation)	
Ambient humidity range	Operation and storage: 40 to 70% (with no condensation)	

Model	FZ-VS4 (15m)	FZ-VSL4 (15m)
Ambient atmosphere	No corrosive gases	
Material	Cable sheath, connector: PVC	
Minimum bending radius	78 mm	
Weight	Approx. 1400g	

*1. This data values are for reference only and not guaranteed values.

Dimensions

● Long-distance Camera Cable: FZ-VS4

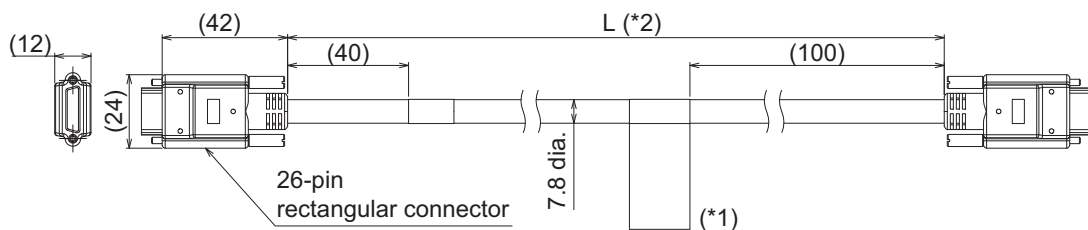

*1. Each camera cables has polarity. Please ensure that the name plate side of the cable is connected to the controller.

*2. Cable is available in 15 m.

(Unit: mm)

● Long-distance Right-angle Camera Cable: FZ-VSL4

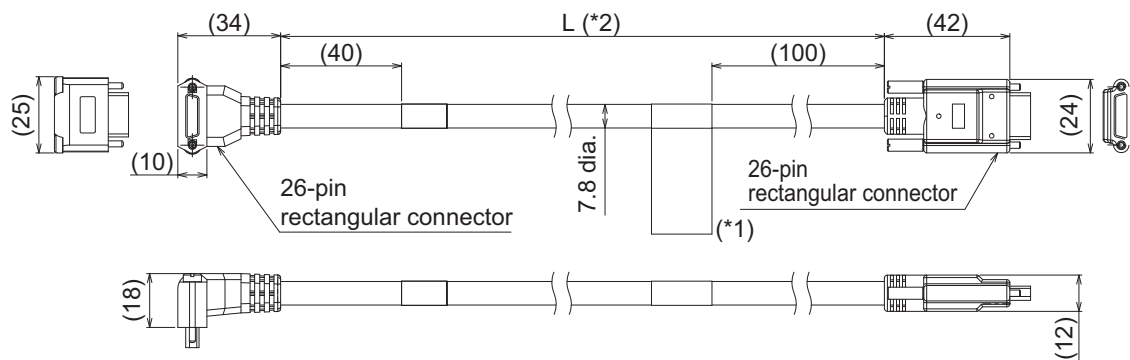

*1. Each camera cables has polarity. Please ensure that the name plate side of the cable is connected to the controller.

*2. Cable is available in 15 m.

(Unit: mm)



Additional Information

We have the 2D CAD data or 3D CAD data.
You can download CAD data from www.fa.omron.co.jp.

3-3-4 Cable Connection Table

For connection of camera cables, refer to the following table.

Camera Cable for FH-S Camera Series

Name	Model	Length	High-speed digital CMOS Camera (Standalone)				
			0.3 mega-pixel camera	2 megapixel camera		4 megapixel camera	
			FH-SM/SC	FH-SM02/SC02		FH-SM04/SC04	
			-	High speed	Standard	High speed	Standard
Camera cable Right-angle Camera cable	FZ-VS3	2 m	OK	OK	OK	OK	OK
	FZ-VSL3	3 m	OK	OK	OK	OK	OK
		5 m	OK	OK	OK	OK	OK
		10 m	OK	-	OK	-	OK
Bend resistant Camera cable Bend resistant Right-angle Camera cable	FZ-VSB3	2 m	OK	OK	OK	OK	OK
	FZ-VSLB3	3 m	OK	OK	OK	OK	OK
		5 m	OK	OK	OK	OK	OK
		10 m	OK	-	OK	-	OK
Long-distance Camera cable Long-distance Right-angle Camera cable	FZ-VS4 FZ-VSL4	15 m	OK	-	OK	-	OK

Name	Model	Length	High-speed digital CMOS Camera (Standalone)		Digital CMOS Camera
			12 megapixel camera		5 megapixel camera
			FH-SM12/SC12		FH-SM05R/SC05R
			High speed	Standard	-
Camera cable Right-angle Camera cable	FZ-VS3	2 m	OK	OK	OK
	FZ-VSL3	3 m	OK	OK	OK
		5 m	OK	OK	OK
		10 m	-	OK	OK
Bend resistant Camera cable Bend resistant Right-angle Camera cable	FZ-VSB3	2 m	OK	OK	OK
	FZ-VSLB3	3 m	OK	OK	OK
		5 m	OK	OK	OK
		10 m	-	OK	OK
Long-distance Camera cable Long-distance Right-angle Camera cable	FZ-VS4 FZ-VSL4	15 m	-	OK	OK

Name	Model	Length	High-speed digital CMOS Camera (Standalone)			
			0.4 megapixel camera		5 megapixel camera	
			FH-SMX/SCX		FH-SMX05/SCX05	
			High speed	Standard	Standard	High speed
Camera cable Right-angle Camera cable	FZ-VS3	2 m	OK	OK	OK	OK
	FZ-VSL3	3 m	OK	OK	OK	OK
		5 m	OK	OK	OK	OK
		10 m	-	OK	-	OK

Name	Model	Length	High-speed digital CMOS Camera (Standalone)			
			0.4 megapixel camera		5 megapixel camera	
			FH-SMX/SCX		FH-SMX05/SCX05	
			High speed	Standard	Standard	High speed
Bend resistant Camera cable	FZ-VSB3	2 m	OK	OK	OK	OK
		3 m	OK	OK	OK	OK
Bend resistant Right-angle Camera cable	FZ-VSLB3	5 m	OK	OK	OK	OK
		10 m	-	OK	-	OK
Long-distance Camera cable	FZ-VS4	15 m	-	OK	-	OK
Long-distance Right-angle Camera cable	FZ-VSL4					

Name	Model	Length	High-speed digital CMOS Camera (Standalone)		Digital CMOS Camera (Standalone)	
			12 megapixel camera		20.4 megapixel camera	
			FH-SMX12/SCX12		FH-SM21R/SC21R	
			High speed	Standard	High speed	Standard
Camera cable Right-angle Camera cable	FZ-VS3 FZ-VSL3	2 m	OK	OK	OK	OK
		3 m	OK	OK	OK	OK
		5 m	OK	OK	OK	OK
		10 m	-	OK	-	OK
Bend resistant Camera cable	FZ-VSB3	2 m	OK	OK	OK	OK
		3 m	OK	OK	OK	OK
Bend resistant Right-angle Camera cable	FZ-VSLB3	5 m	OK	OK	OK	OK
		10 m	-	OK	-	OK
Long-distance Camera cable	FZ-VS4	15 m	-	OK	-	OK
Long-distance Right-angle Camera cable	FZ-VSL4					

Camera Cable for FZ-S Camera Series

Name	Model	Length	Digital CCD Camera (Standalone)		
			0.3 megapixel camera	2 megapixel camera	5 megapixel camera
			FZ-S/SC	FZ-S2M/SC2M	FZ-S5M3/SC5M3
Camera cable Right-angle Camera cable	FZ-VS3	2 m	OK	OK	OK
	FZ-VSL3	3 m	OK	OK	OK
		5 m	OK	OK	OK
		10 m	OK	OK	-
Bend resistant Camera cable	FZ-VSB3	2 m	OK	OK	OK
		3 m	OK	OK	OK
Bend resistant Right-angle Camera cable	FZ-VSLB3	5 m	OK	OK	OK
		10 m	OK	OK	-
Long-distance Camera cable	FZ-VS4	15 m	OK	OK	-
Long-distance Right-angle Camera cable	FZ-VSL4				

Name	Model	Length	Small Digital CCD Camera (Standalone)	High-speed digital CCD Camera (Standalone)	Intelligent Compact Digital CMOS Camera
			Flat type/pen type		
			FZ-SF/SFC FZ-SP/SPC	FZ-SH/SHC	FZ-SQ□
Camera cable Right-angle Camera cable	FZ-VS3	2 m	OK	OK	OK
	FZ-VSL3	3 m	OK	OK	OK
		5 m	OK	OK	OK
		10 m	OK	OK	OK
Bend resistant Camera cable	FZ-VSB3	2 m	OK	OK	OK
		3 m	OK	OK	OK
Bend resistant Right-angle Camera cable	FZ-VSLB3	5 m	OK	OK	OK
		10 m	OK	OK	OK
Long-distance Camera cable	FZ-VS4	15 m	OK	OK	OK
Long-distance Right-angle Camera cable	FZ-VSL4				

3-3-5 Cable Extension Units

You can extend the distance between the Sensor Controller and Camera by using cable extension units.

Specification

Model	FZ-VSJ
Supply Voltage *1	11.5 to 13.5 VDC
Current consumption *2	1.5 A max.
Ambient temperature range	Operating: 0 to +50°C; Storage: -25 to +65°C (with no icing or condensation)
Ambient humidity range	Operating and Storage: 35 to 85% (with no condensation)
Weight	Approx. 240g
Accessories	Instruction Sheet and 4 mounting screws

*1. A 12-VDC power supply must be provided to the Cable Extension Unit when connecting the Intelligent Compact Digital Camera, or the Lighting Controller.

*2. The current consumption shows when connecting the Cable Extension Unit to an external power supply.

Dimensions

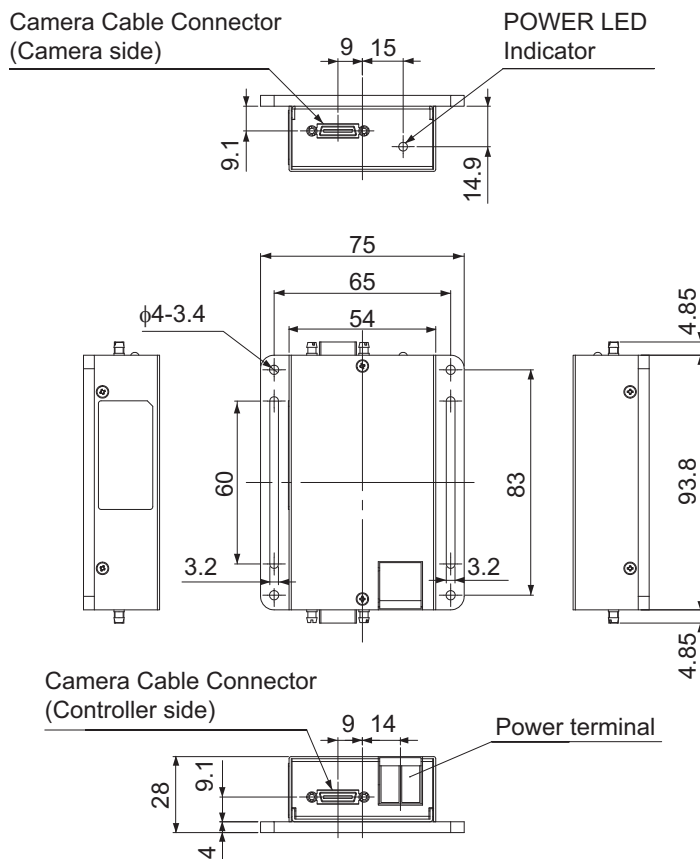

(Unit: mm)



Additional Information

We have the 2D CAD data or 3D CAD data.
You can download CAD data from www.fa.omron.co.jp.

Maximum Extension Length Using Cable Extension Units FZ-VSJ

Item	Model	Transmission speed *1	No. of CH used for connection *2	Maximum cable length using 1 Camera Cable *1	Max. number of connectable Extension Units	Using Cable Extension Units FZ-VSJ	
						Max. cable length	Connection configuration
High-speed digital CMOS Cameras	FH-SM/SC	-	-	15 m (Using FZ-VS4/VSL4)	2	45 m	[Configuration 1] Camera cable: 15 m x 3 Extension Unit: 2
	FH-SMX/SCX	Standard	-	15 m (Using FZ-VS4/VSL4)	2	45 m	[Configuration 1] Camera cable: 15 m x 3 Extension Unit: 2
		High speed	-	5 m (Using FZ-VS □/VSL□)	2	15 m	[Configuration 3] Camera cable: 15 m x 3 Extension unit: 2
	FH-SM02/SC02 FH-SM04/SC04 FH-SM12/SC12 FH-SMX05/ SCX05 FH-SMX12/ SCX12	Standard	1CH	15 m (Using FZ-VS4/VSL4)	2	45 m	[Configuration 1] Camera cable: 15 m x 3 Extension Unit: 2
		High speed	2CH	15 m (Using FZ-VS4/VSL4)	4 *3	45 m	[Configuration 2] Camera cable: 15 m x 6 Extension Unit: 4
		Standard	1CH	5 m (Using FZ-VS □/VSL□)	2	15 m	[Configuration 3] Camera cable: 15 m x 3 Extension unit: 2
		High speed	2CH	5 m (Using FZ-VS □/VSL□)	4 *3	15 m	[Configuration 4] Camera cable: 5 m x 6 Extension Unit: 4

Item	Model	Transmission speed *1	No. of CH used for connection *2	Maximum cable length using 1 Camera Cable *1	Max. number of connectable Extension Units	Using Cable Extension Units FZ-VSJ	
						Max. cable length	Connection configuration
Digital CMOS Cameras	FH-SM21R/SC21R	Standard	1CH	15 m (Using FZ-VS4/VSL4)	2	45 m	[Configuration 1] Camera cable: 15 m x 3 Extension Unit: 2
			2CH	15 m (Using FZ-VS4/VSL4)	4 *3	45 m	[Configuration 2] Camera cable: 15 m x 6 Extension Unit: 4
		High speed	1CH	15 m (Using FZ-VS4/VSL4)	2	15 m	[Configuration 3] Camera cable: 15 m x 3 Extension unit: 2
			2CH	5 m (Using FZ-VS□/VSL□)	4 *3	15 m	[Configuration 4] Camera cable: 5 m x 6 Extension Unit: 4
	FH-SM05R/SC05R	-	-	15 m (Using FZ-VS4/VSL4)	2	45 m	[Configuration 1] Camera cable: 15 m x 3 Extension Unit: 2
	FZ-S5M3/SC5M3	-	-	5 m (Using FZ-VS□/VSL□)	2	15 m	[Configuration 3] Camera cable: 15 m x 3 Extension unit: 2
Digital CCD/CMOS Cameras	FZ-S/SC FZ-S2M/SC2M	-	-	15 m (Using FZ-VS4/VSL4)	2	45 m	[Configuration 1] Camera cable: 15 m x 3 Extension Unit: 2
Small Digital CCD Cameras Flat type/pen type	FZ-SF/SFC FZ-SP/SPC	-	-	15 m (Using FZ-VS4/VSL4)	2	45 m	[Configuration 1] Camera cable: 15 m x 3 Extension Unit: 2
High-speed digital CCD Cameras	FZ-SH/SHC	-	-	15 m (Using FZ-VS4/VSL4)	2	45 m	[Configuration 1] Camera cable: 15 m x 3 Extension Unit: 2
Intelligent Compact Digital CMOS Cameras	FZ-SQ□	-	-	15 m (Using FZ-VS4/VSL4)	2	45 m	[Configuration 1] Camera cable: 15 m x 3 Extension Unit: 2

*1. The FH-S□□□ enables switching between standard and high speed modes. In high speed mode, images can be transferred approximately two times faster than in standard mode, but the connectable cable length will be shorter.

- *2. The FH-S□□□ has two channels to connect Camera Cables. Connection to two channels makes image transfer two times faster than connection to one channel: high speed mode using two channels can transfer approximately four times as many images as standard mode using one channel.
- *3. Each channel can be used to connect up to two Cable Extension Units: up to four extension units, two units per one channel, can be connected by using two channels.

Connection Configuration

Connection configuration of FH-1000/2000/3000/5000 Sensor Controller and Camera are the bellows.

Con-figu-ra-tion	Connection configuration using the maximum length of Camera Cables	Remarks
1		-
2		Camera cable connector CH2 Camera cable connector CH1
3		-
4		Camera cable connector CH2 Camera cable connector CH1





- *1. Select the Camera Cables between the Controller and Extension Unit, between the Extension Units, and between the Extension Unit and Camera according to the connected Camera. Different types or lengths of Camera Cables can be used for (1), (2), and (3) as well as for (4), (5), and (6). However, the type and length of Camera Cable (1) must be the same as those of Camera Cable (4), (2) must be the same as (5), and (3) must be the same as (6).





3-4 Lens



3-4-1 C-mount Lens for 1/3-inch Image Sensor (SV-V Series)

FH-S, FZ-SH, and FZ-S are recommended.

Specification

Model	3Z4S-LE SV-03514V	3Z4S-LE SV-04514V	3Z4S-LE SV-0614V	3Z4S-LE SV-0813V
Appearance/ Dimensions (Unit: mm)	 29.5 dia. 30.4	 29.5 dia. 29.5	 29 dia. 30.0	 28 dia. 34.0
Focal length (mm)	3.5	4.5	6	8
Aperture (F No.)	1.4 to Close	1.4 to Close	1.4 to Close	1.3 to Close
Filter size	-	-	M27.0 P0.5	M25.5 P0.5
Maximum sensor size	1/3 inch			
Mount	C mount			

Model	3Z4S-LE SV-1214V	3Z4S-LE SV-1614V	3Z4S-LE SV-2514V	3Z4S-LE SV-3518V
Appearance/ Dimensions (Unit: mm)	 29 dia. 29.5	 29 dia. 24.0	 29 dia. 24.5	 29 dia. 33.5 [WD: ∞] to 37.5 [WD: 300]
Focal length (mm)	12	16	25	35
Aperture (F No.)	1.4 to Close	1.4 to Close	1.4 to Close	1.8 to Close
Filter size	M27.0 P0.5	M27.0 P0.5	M27.0 P0.5	M27.0 P0.5
Maximum sensor size	1/3 inch			
Mount	C mount			

Model	3Z4S-LE SV-5018V	3Z4S-LE SV-7527V	3Z4S-LE SV-10035V
Appearance/ Dimensions (Unit: mm)	 32 dia. 37.0 [WD: ∞] to 39.4 [WD: 1000]	 32 dia. 42.0 [WD: ∞] to 44.4 [WD: 1000]	 32 dia. 43.9 [WD: ∞] to 46.3 [WD: 1000]
Focal length (mm)	50	75	100
Aperture (F No.)	1.8 to Close	2.7 to Close	3.5 to Close
Filter size	M30.5 P0.5	M30.5 P0.5	M30.5 P0.5
Maximum sensor size	1/3 inch		





Model	3Z4S-LE SV-5018V	3Z4S-LE SV-7527V	3Z4S-LE SV-10035V
Mount	C mount		





3-4-2 C-mount Lens for 2/3-inch Image Sensor (SV-H Series)

FZ-S□2M, FZ-S□5M□, and FH-S□05R are recommended.

3Z4S-LE SV-7525H and 3Z4S-LE SV-10028H are also available to use FH-S□02/FH-S□04.

Specification

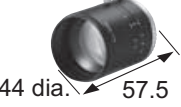
Model	3Z4S-LE SV-0614H	3Z4S-LE SV-0814H	3Z4S-LE SV-1214H	3Z4S-LE SV-1614H
Appearance/ Dimensions (Unit: mm)				
Focal length (mm)	6	8	12	16
Aperture (F No.)	1.4 to 16	1.4 to 16	1.4 to 16	1.4 to 16
Filter size	M40.5 P0.5	M35.5 P0.5	M27.0 P0.5	M27.0 P0.5
Maximum sensor size	2/3 inch			
Mount	C mount			

Model	3Z4S-LE SV-2514H	3Z4S-LE SV-3514H	3Z4S-LE SV-5014H	3Z4S-LE SV-7525H
Appearance/ Dimensions (Unit: mm)				
Focal length (mm)	25	35	50	75
Aperture (F No.)	1.4 to 16	1.4 to 16	1.4 to 16	2.5 to Close
Filter size	M27.0 P0.5	M35.5 P0.5	M40.5 P0.5	M34.0 P0.5
Maximum sensor size	2/3 inch			1 inch
Mount	C mount			

Model	3Z4S-LE SV-10028H
Appearance/ Dimensions (Unit: mm)	
Focal length (mm)	100
Aperture (F No.)	2.8 to Close
Filter size	M37.5 P0.5





Model	3Z4S-LE SV-10028H
Maximum sensor size	1 inch
Mount	C mount



3-4-3 C-mount Lens for 1-inch Image Sensor (VS-H1 Series)

FH-S□02 and FH-S□04 are recommended.

When the focal distance is 75 mm or 100 mm, 3Z4S-LE SV-7525H and 3Z4S-LE SV-10028H are also available.





Specification

Model	3Z4S-LE VS-0618H1	3Z4S-LE VS-0814H1	3Z4S-LE VS-1214H1	3Z4S-LE VS-1614H1N
Appearance/ Dimensions (Unit: mm)	 64.5 dia. 57.2	 57 dia. 59	 38 dia. 48.0[WD:∞] to 48.5[WD:300]	 38 dia. 45.0[WD:∞] to 45.9[WD:300]
Focal length (mm)	6	8	12	16
Aperture (F No.)	1.8 to 16	1.4 to 16	1.4 to 16	1.4 to 16
Filter size	Can not be used a filter.	M55.0 P0.75	M35.5 P0.5	M30.5 P0.5
Maximum sensor size	1 inch			
Mount	C mount			

Model	3Z4S-LE VS-2514H1	3Z4S-LE VS-3514H1	3Z4S-LE VS-5018H1
Appearance/ Dimensions (Unit: mm)	 38 dia. 33.5[WD:∞] to 35.6[WD:300]	 38 dia. 35.0[WD:∞] to 39.1[WD:300]	 44 dia. 44.5[WD:∞] to 49.5[WD:500]
Focal length (mm)	25	35	50
Aperture (F No.)	1.4 to 16	1.4 to 16	1.8 to 16
Filter size	M30.5 P0.5	M30.5 P0.5	M40.5 P0.5
Maximum sensor size	1 inch		
Mount	C mount		

3-4-4 C-mount Lens for 4/3-inch Image Sensor (VS-LLD Series)

Specification





Model	3Z4S-LE VS-LLD12.5	3Z4S-LE VS-LLD18	3Z4S-LE VS-LLD25	3Z4S-LE VS-LLD50
Appearance/ Dimensions (Unit: mm)				
Focal length (mm)	12.5	18	25	35
Aperture (F No.)	2.5 to 16	2.1 to 16	2.1 to 16	2.2 to 16
Filter size	M62.0 P0.75	M43.0 P0.75	M43.0 P0.75	M46.0 P0.75
Maximum sensor size	4/3 inch			
Mount	C mount			



Model	3Z4S-LE VS-LLD50
Appearance/ Dimensions (Unit: mm)	
Focal length (mm)	50
Aperture (F No.)	2.2 to 16
Filter size	M46 P0.75
Maximum sensor size	4/3 inch
Mount	C mount

3-4-5 M42-mount Lens for Large Image Sensor (VS-L/M42-10 Series)

FH-S□12 is recommended.

Specification





Model	3Z4S-LE VS-L1828/M42-10	3Z4S-LE VS-L2526/M42-10	3Z4S-LE VS-L3528/M42-10	3Z4S-LE VS-L5028/M42-10
Appearance/ Dimensions (Unit: mm)				
Focal length (mm)	18	25	35	50
Aperture (F No.)	2.8 to 16	2.6 to 16	2.8 to 16	2.8 to 16
Filter size	M55.0 P0.75	M55.0 P0.75	M62.0 P0.75	M62.0 P0.75
Maximum sensor size	1.8 inch			
Mount	M42 mount			

Model	3Z4S-LE VS-L1828/M42-10	3Z4S-LE VS-L2526/M42-10
Appearance/ Dimensions (Unit: mm)		
Focal length (mm)	85	100
Aperture (F No.)	4.0 to 16	2.8 to 16
Filter size	M52.0 P0.75	M52.0 P0.75
Maximum sensor size	1.8 inch	
Mount	M42 mount	

3-4-6 Lenses for Small Camera (FZ-LES Series)

FZ-SF, FZ-SFC, FZ-SP, and FZ-SPC are recommended.

Specification

Model	FZ-LES3	FZ-LES6	FZ-LES16	FZ-LES50
Appearance/ Dimensions (Unit: mm)				
Focal length (mm)	3	6	16	30
Aperture (F No.)	2.0 to 16	2.0 to 16	3.4 to 16	3.4 to 16

3-4-7 Vibration and Shock Resistant C-mount Lens for 2/3-inch Image Sensor (VS-MCA Series)

FZ-S□, FZ-S□2M, FZ-S□5M□, FZ-SH□, and FH-S□□5R are recommended.

Specification

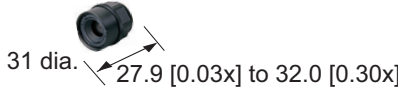
Model	3Z4S-LE VS-MCA15-□□□□*1								
Appearance/ Dimensions (Unit: mm)									
Focal length (mm)	15								
Filter size	M27.0 P0.5								
Optical magnification	0.03x			0.20x			0.30x		
Aperture (fixed F No.)	2	5.6	8	2	5.6	8	2	5.6	8
Depth of field (mm) *2	186.7	515.6	728.9	4.8	13.4	19.2	2.3	6.5	9.2
Maximum sensor size	2/3 inch								
Mount	C mount								

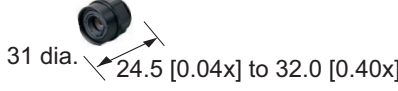
Model	3Z4S-LE VS-MCA20-□□□□*1								
Appearance/ Dimensions (Unit: mm)									
Focal length (mm)	20								
Filter size	M27.0 P0.5								
Optical magnification	0.04x			0.25x			0.40x		
Aperture (fixed F No.)	2	5.6	8	2	5.6	8	2	5.6	8
Depth of field (mm) *2	105.0	290.0	415.0	3.2	9.0	12.8	1.5	3.9	5.6
Maximum sensor size	2/3 inch								
Mount	C mount								

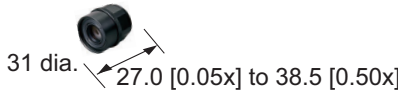
Model	3Z4S-LE VS-MCA25-□□□□*1								
Appearance/ Dimensions (Unit: mm)									
Focal length (mm)	25								
Filter size	M27.0 P0.5								

Model	3Z4S-LE VS-MCA25-□□□□*1								
Optical magnification	0.05x			0.25x			0.50x		
Aperture (fixed F No.)	2	5.6	8	2	5.6	8	2	5.6	8
Depth of field (mm) *2	67.2	188.8	268.8	3.2	9.0	12.8	1.0	2.7	3.8
Maximum sensor size	2/3 inch								
Mount	C mount								

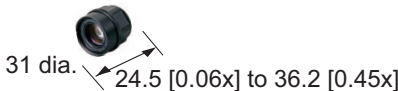
Model	3Z4S-LE VS-MCA30-□□□□*1								
Appearance/ Dimensions (Unit: mm)									
Focal length (mm)	30								
Filter size	M27.0 P0.5								
Optical magnification	0.06x			0.15x			0.45x		
Aperture (fixed F No.)	2	5.6	8	2	5.6	8	2	5.6	8
Depth of field (mm) *2	53.3	131.1	188.9	8.2	22.8	32.7	1.3	3.2	4.6
Maximum sensor size	2/3 inch								
Mount	C mount								

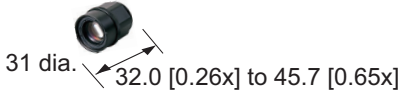
Model	3Z4S-LE VS-MCA35-□□□□*1								
Appearance/ Dimensions (Unit: mm)									
Focal length (mm)	35								
Filter size	M27.0 P0.5								
Optical magnification	0.26x			0.30x			0.65x		
Aperture (fixed F No.)	2	5.6	8	2	5.6	8	2	5.6	8
Depth of field (mm) *2	3.0	8.4	12.0	2.2	6.5	9.2	0.7	1.7	2.5
Maximum sensor size	2/3 inch								
Mount	C mount								

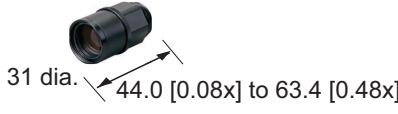
Model	3Z4S-LE VS-MCA50-□□□□*1								
Appearance/ Dimensions (Unit: mm)									
Focal length (mm)	50								
Filter size	M27.0 P0.5								
Optical magnification	0.08x			0.20x			0.48x		
Aperture (fixed F No.)	2	5.6	8	2	5.6	8	2	5.6	8
Depth of field (mm) *2	32.5	75.0	107.5	6.0	13.4	19.2	1.3	2.9	4.1
Maximum sensor size	2/3 inch								
Mount	C mount								

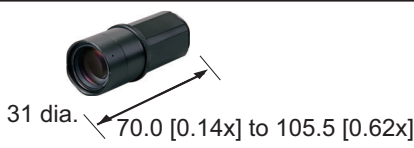
Model	3Z4S-LE VS-MCA75-□□□□*1								
Appearance/ Dimensions (Unit: mm)									
Focal length (mm)	75								
Filter size	M27.0 P0.5								
Optical magnification	0.14x			0.20x			0.62x		
Aperture (fixed F No.)	2	5.6	8	2	5.6	8	2	5.6	8
Depth of field (mm) *2	16.7	28.6	41.2	9.2	13.4	19.2	1.3	2.5	3.6
Maximum sensor size	2/3 inch								
Mount	C mount								

*1. Insert the aperture into □□□□ in the model number as follows.

F=2.0: blank

F=5: F5.6

F=8: F8

*2. When circle of least confusion is 0.04mm.

3-4-8 Vibration and Shock Resistant C-mount Lens for 1-inch Image Sensor (VS-MCH Series)

FH-S□04 and FH-S□21R are recommended.

Specification

Model	3Z4S-LE VS-MCH12-□□□□□*1								
Appearance/ Dimensions (Unit: mm)	 38dia. 48.0[0.025x] to 49.8[0.15x]								
Focal length (mm)	12								
Filter size	M35.5 P0.5								
Optical magnification	0.025x			0.10x			0.15x		
Aperture (fixed F No.)*2	2	5.6	8	2	5.6	8	2	5.6	8
Depth of field (mm) *3	262.0	735.0	1050.0	17.6	49.3	70.4	8.2	22.9	32.7
Maximum sensor size	1 inch								
Mount	C mount								

Model	3Z4S-LE VS-MCH16N-□□□□□*1								
Appearance/ Dimensions (Unit: mm)	 38dia. 45.4 [0.025x] to 49.1 [0.15x]								
Focal length (mm)	16								
Filter size	M34.0 P0.5								
Optical magnification	0.025x			0.10x			0.25x		
Aperture (fixed F No.)*2	2	5.6	8	2	5.6	8	2	5.6	8
Depth of field (mm) *3	262.0	735.0	1050.0	17.6	49.3	70.4	3.2	9.0	12.8
Maximum sensor size	1 inch								
Mount	C mount								

Model	3Z4S-LE VS-MCH25-□□□□□*1								
Appearance/ Dimensions (Unit: mm)	 38dia. 33.5 [0.025x] to 44.2 [0.35x]								
Focal length (mm)	25								
Filter size	M34.0 P0.5								
Optical magnification	0.025x			0.10x			0.35x		
Aperture (fixed F No.)*2	2	5.6	8	2	5.6	8	2	5.6	8

Model	3Z4S-LE VS-MCH25-□□□□□*1								
Depth of field (mm) *3	262.0	735.0	1050.0	17.6	49.3	70.4	1.8	4.9	7.1
Maximum sensor size	1 inch								
Mount	C mount								

Model	3Z4S-LE VS-MCH35-□□□□□*1								
Appearance/Dimensions (Unit: mm)	 38dia. 35.0 [0.025x] to 43.8 [0.25x]								
Focal length (mm)	35								
Filter size	M34.0 P0.5								
Optical magnification	0.025x			0.10x			0.25x		
Aperture (fixed F No.) *2	2	5.6	8	2	5.6	8	2	5.6	8
Depth of field (mm) *3	262.0	735.0	1050.0	17.6	49.3	70.4	1.8	4.9	7.1
Maximum sensor size	1 inch								
Mount	C mount								

Model	3Z4S-LE VS-MCH50-□□□□□*1								
Appearance/Dimensions (Unit: mm)	 43dia. 44.5 [0.025x] to 52.0 [0.15x]								
Focal length (mm)	50								
Filter size	M40.5 P0.5								
Optical magnification	0.025x			0.10x			0.15x		
Aperture (fixed F No.) *2	2	5.6	8	2	5.6	8	2	5.6	8
Depth of field (mm) *3	262.0	735.0	1050.0	17.6	49.3	70.4	8.2	22.9	32.7
Maximum sensor size	1 inch								
Mount	C mount								

Model	3Z4S-LE VS-MCH75-□□□□□*1								
Appearance/Dimensions (Unit: mm)	 38dia. 49.5 [0.025x] to 60.7 [0.15x]								
Focal length (mm)	75								
Filter size	M34.0 P0.5								

Model	3Z4S-LE VS-MCH75-□□□□□*1								
Optical magnification	0.025x			0.10x			0.15x		
Aperture (fixed F No.) ^{*2}	2.5	5.6	8	2.5	5.6	8	2.5	5.6	8
Depth of field (mm) ^{*3}	262.0	735.0	1050.0	17.6	49.3	70.4	8.2	22.9	32.7
Maximum sensor size	1 inch								
Mount	C mount								

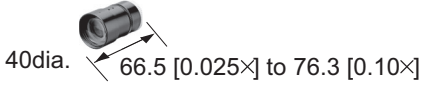
Model	3Z4S-LE VS-MCH100-□□□□□*1								
Appearance/Dimensions (Unit: mm)									
Focal length (mm)	100								
Filter size	M35.5 P0.5								
Optical magnification	0.025x			0.05x			0.10x		
Aperture (fixed F No.) ^{*2}	2.8	5.6	8	2.8	5.6	8	2.8	5.6	8
Depth of field (mm) ^{*3}	262.0	735.0	1050.0	94.1	188.2	268.8	17.6	49.3	70.4
Maximum sensor size	1 inch								
Mount	C mount								

*1. Insert the aperture into □□□□□ in the model number as follows.

F = 2.0 to 2.8: blank

F = 5.6: FN056

F = 8: FN080

*2. F-number can be selected from maximum aperture, 5.6, and 8.0.

*3. When circle of least confusion is 40 μm.

3-4-9 Vibration and Shock Resistant C-mount Lens for 1-inch Image Sensor (VS-MCH1 Series)

FH-S□02, FH-S□04, or FH-S□21R are recommended.

Specification

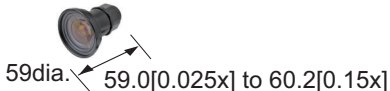
Model	3Z4S-LE VS-MC08H1-□□□□□*1								
Appearance/Dimensions (Unit: mm)									
Focal length (mm)	8								
Filter size	M55.0 P0.75								

Model	3Z4S-LE VS-MC08H1-□□□□□*1								
Optical magnification	0.025x			0.10x			0.15x		
Aperture (fixed F No.) ^{*2}	1.4	5.6	8	1.4	5.6	8	1.4	5.6	8
Depth of field (mm) ^{*3}	179.0	735.0	1050.0	12.0	49.3	70.4	5.7	22.9	32.7
Maximum sensor size	1 inch								
Mount	C mount								

Model	3Z4S-LE VS-MC12H1-□□□□□*1								
Appearance/Dimensions (Unit: mm)	 38dia. 48.0[0.025x] to 49.8[0.15x]								
Focal length (mm)	12								
Filter size	M35.5 P0.5								
Optical magnification	0.025x			0.10x			0.15x		
Aperture (fixed F No.) ^{*2}	1.4	5.6	8	1.4	5.6	8	1.4	5.6	8
Depth of field (mm) ^{*3}	179.0	735.0	1050.0	12.0	49.3	70.4	5.7	22.9	32.7
Maximum sensor size	1 inch								
Mount	C mount								

Model	3Z4S-LE VS-MC16H1-□□□□□*1								
Appearance/Dimensions (Unit: mm)	 36.5dia. 45.4[0.025x] to 49.1[0.25x]								
Focal length (mm)	16								
Filter size	M30.5 P0.5								
Optical magnification	0.025x			0.10x			0.25x		
Aperture (fixed F No.) ^{*2}	1.4	5.6	8	1.4	5.6	8	1.4	5.6	8
Depth of field (mm) ^{*3}	179.0	735.0	1050.0	12.0	49.3	70.4	2.3	9.0	12.8
Maximum sensor size	1 inch								
Mount	C mount								

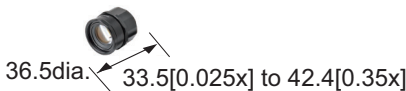
Model	3Z4S-LE VS-MC25H1-□□□□□*1								
Appearance/ Dimensions (Unit: mm)									
Focal length (mm)	25								
Filter size	M30.5 P0.5								
Optical magnification	0.025x			0.10x			0.35x		
Aperture (fixed F No.)*2	1.4	5.6	8	1.4	5.6	8	1.4	5.6	8
Depth of field (mm) *3	179.0	735.0	1050.0	12.0	49.3	70.4	1.2	4.9	7.1
Maximum sensor size	1 inch								
Mount	C mount								

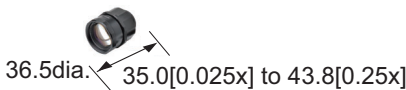
Model	3Z4S-LE VS-MC35H1-□□□□□*1								
Appearance/ Dimensions (Unit: mm)									
Focal length (mm)	35								
Filter size	M30.5 P0.5								
Optical magnification	0.025x			0.10x			0.25x		
Aperture (fixed F No.)*2	1.4	5.6	8	1.4	5.6	8	1.4	5.6	8
Depth of field (mm) *3	179.0	735.0	1050.0	12.0	49.3	70.4	2.3	9.0	12.8
Maximum sensor size	1 inch								
Mount	C mount								

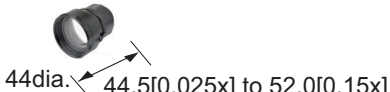
Model	3Z4S-LE VS-MC50H1-□□□□□*1								
Appearance/ Dimensions (Unit: mm)									
Focal length (mm)	50								
Filter size	M40.5 P0.5								
Optical magnification	0.025x			0.10x			0.15x		
Aperture (fixed F No.)*2	1.4	5.6	8	1.4	5.6	8	1.4	5.6	8
Depth of field (mm) *3	179.0	735.0	1050.0	12.0	49.3	70.4	5.7	22.9	32.7
Maximum sensor size	1 inch								

Model	3Z4S-LE VS-MC50H1-□□□□□*1
Mount	C mount

- *1. Insert the aperture into □□□□□ in the model number as follows.
 F = 1.4: blank
 F = 5.6: FN056
 F = 8: FN080
- *2. F-number can be selected from maximum aperture, 5.6, and 8.0.
- *3. When circle of least confusion is 40 μm.

3-4-10 Vibration and Shock Resistant M42-mount Lens for 1.8-inch Image Sensor (VS-MCL/M42-10 Series)

FH-S□12 is recommended.

Specification

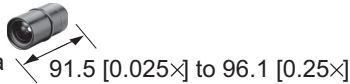
Model	3Z4S-LE VS-MCL18-□□□□□/M42-10*1								
Appearance/ Dimensions (Unit: mm)									
Focal length (mm)	18								
Filter size	M46.0 P0.75								
Optical magnification	0.025x			0.10x			0.25x		
Aperture (fixed F No.) ^{*2}	2.8	5.6	8	2.8	5.6	8	2.8	5.6	8
Depth of field (mm) ^{*3}	367.0	735.0	1050.0	24.6	49.3	70.4	4.5	9.0	12.8
Maximum sensor size	1.8 inch								
Mount	M42 mount								

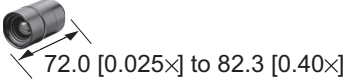
Model	3Z4S-LE VS-MCL25-□□□□□/M42-10*1								
Appearance/ Dimensions (Unit: mm)									
Focal length (mm)	25								
Filter size	M46.0 P0.75								
Optical magnification	0.025x			0.10x			0.40x		
Aperture (fixed F No.) ^{*2}	2.6	5.6	8	2.6	5.6	8	2.6	5.6	8
Depth of field (mm) ^{*3}	367.0	735.0	1050.0	24.6	49.3	70.4	1.8	3.9	5.6
Maximum sensor size	1.8 inch								

Model	3Z4S-LE VS-MCL25-□□□□□/M42-10*1
Mount	M42 mount

Model	3Z4S-LE VS-MCL35-□□□□□/M42-10*1								
Appearance/ Dimensions (Unit: mm)	 55dia. 99.5 [0.025x] to 117.6 [0.35x]								
Focal length (mm)	35								
Filter size	M52.0 P0.75								
Optical magnification	0.025x			0.20x			0.50x		
Aperture (fixed F No.)*2	2.8	5.6	8	2.8	5.6	8	2.8	5.6	8
Depth of field (mm) *3	367.0	735.0	1050.0	6.5	13.4	19.2	2.0	3.9	5.6
Maximum sensor size	1.8 inch								
Mount	M42 mount								

Model	3Z4S-LE VS-MCL50-□□□□□/M42-10*1								
Appearance/ Dimensions (Unit: mm)	 52dia. 64.0 [0.05x] to 82.0 [0.40x]								
Focal length (mm)	50								
Filter size	M46.0 P0.75								
Optical magnification	0.05x			0.20x			0.40x		
Aperture (fixed F No.)*2	2.8	5.6	8	2.8	5.6	8	2.8	5.6	8
Depth of field (mm) *3	97.6	188.0	269.0	6.5	13.4	19.2	2.0	3.9	5.6
Maximum sensor size	1.8 inch								
Mount	M42 mount								

Model	3Z4S-LE VS-MCL85-□□□□□/M42-10*1								
Appearance/ Dimensions (Unit: mm)	 52dia. 105.0 [0.05x] to 130.2 [0.35x]								
Focal length (mm)	85								
Filter size	M46.0 P0.75								
Optical magnification	0.05x			0.30x			0.35x		
Aperture (fixed F No.)*2	4	5.6	8	4	5.6	8	4	5.6	8

Model	3Z4S-LE VS-MCL85-□□□□□/M42-10*1								
Depth of field (mm) *3	134.0	188.0	269.0	4.6	6.5	9.2	3.5	4.9	7.1
Maximum sensor size	1.8 inch								
Mount	M42 mount								

Model	3Z4S-LE VS-MCL100-□□□□□/M42-10*1								
Appearance/Dimensions (Unit: mm)	 52dia. 110.0 [0.05x] to 135.0 [0.30x]								
Focal length (mm)	100								
Filter size	M46.0 P0.75								
Optical magnification	0.05x			0.20x			0.30x		
Aperture (fixed F No.)*2	2.8	5.6	8	2.8	5.6	8	2.8	5.6	8
Depth of field (mm) *3	94.1	188.0	269.0	6.5	13.4	19.2	3.2	6.5	9.2
Maximum sensor size	1.8 inch								
Mount	M42 mount								

- *1. Insert the aperture into □□□□□ in the model number as follows.
 F = 2.6 to 4.0: blank
 F = 5.6: FN056
 F = 8: FN080
- *2. F-number can be selected from maximum aperture, 5.6, and 8.0.
- *3. When circle of least confusion is 40 μm.

3-4-11 High-resolution Telecentric Lens for C-mount Lens for 2/3-inch Image Sensor (VS-TCH Series)

FZ-S□, FZ-SH□, FZ-S□2M, FZ-S□5M□, and FH-S□ are recommended.

Specification

Model*1		3Z4S-LE VS-TCH05 -65□□□□	3Z4S-LE VS-TCH05 -110□□□□	3Z4S-LE VS-TCH1 -65□□□□	3Z4S-LE VS-TCH1 -110□□□□
Optical magnification (±5 %)		0.5x		1.0x	
Field of view (±5%) (V x H) (mm)	FH-SC/SM	1/3 inch equivalent	9.6 x 7.2	4.8 x 3.6	
	FH-S□05R	1/2.5 inch equivalent	11.4 x 10.6	5.7 x 4.28	
	FZ-SC/S	1/3 inch equivalent	9.6 x 7.2	4.8 x 3.6	
	FZ-SC2M/S2M	1/1.8 inch equivalent	14.0 x 10.6	7.0 x 5.3	
	FZ-SC5M□/S5M□	2/3 inch equivalent	16.8 x 14.2	8.4 x 7.1	

Model*1	3Z4S-LE VS-TCH05 -65□□□□	3Z4S-LE VS-TCH05 -110□□□□	3Z4S-LE VS-TCH1 -65□□□□	3Z4S-LE VS-TCH1 -110□□□□
WD (mm)*2	75.3	110.8	68.8	110.3
Effective FNO	9.42	9.49	9.94	10.49
Depth of field (mm) *3	3	3.04	0.8	0.84
Resolution (μm) *4	12.43	12.9	6.71	6.99
TV distortion	0.02 %	0.02 %	0.01 %	0.02 %
Maximum sensor size	2/3 inch			

Model*1	3Z4S-LE VS-TCH1.5 -65□□□□	3Z4S-LE VS-TCH1.5 -110□□□□	3Z4S-LE VS-TCH2 -65□□□□	3Z4S-LE VS-TCH2 -110□□□□
Optical magnification (±5 %)	1.5x		2.0x	
Field of view (±5%) (V x H) (mm)	FH-SC/SM	1/3 inch equivalent	3.2 x 2.4	
	FH-S□05R	1/2.5 inch equivalent	3.8 x 2.85	
	FZ-SC/S	1/3 inch equivalent	3.2 x 2.4	
	FZ-SC2M/S2M	1/1.8 inch equivalent	4.7 x 3.5	
	FZ-SC5M□/S5M□	2/3 inch equivalent	5.6 x 4.7	
WD (mm)*2	65	110.8	65	110.8
Effective FNO	11.8	11.97	13.6	13.5
Depth of field (mm) *3	0.4	0.43	0.3	0.27
Resolution (μm) *4	5.24	5.33	4.53	4.53
TV distortion	0.01 %	0.02 %	0.03 %	0.03 %
Maximum sensor size	2/3 inch			

Model*1		3Z4S-LE VS-TCH4 -65□□□□	3Z4S-LE VS-TCH4 -110□□□□
Optical magnification (±5 %)		4.0x	
Field of view (±5%) (V x H) (mm)	FH-SC/SM	1/3 inch equivalent	1.2 x 0.9
	FH-S□05R	1/2.5 inch equivalent	1.43 x 1.07
	FZ-SC/S	1/3 inch equivalent	1.2 x 0.9
	FZ-SC2M/S2M	1/1.8 inch equivalent	1.8 x 1.3
	FZ-SC5M□/S5M□	2/3 inch equivalent	2.1 x 1.8
WD (mm)*2		65	110.8
Effective FNO		17.91	22.2
Depth of field (mm) *3		0.09	0.11
Resolution (μm) *4		3	3.73
TV distortion		0.02 %	0.03 %
Maximum sensor size		2/3 inch	

*1. Insert the shape into □□□□ in the model number as follows.

Straight: -O

Coaxial: CO-O

*2. The working distance is the distance from the end of the lens to the sensor.

*3. The depth of field is calculated using a permissible circle of confusion diameter of 0.04 mm.

*4. The resolution is calculated using a wavelength of 550 nm.



Precautions for Correct Use

- (1) Fixing the lens or other reinforcement may be required depending on the installation angle or operating environment (vibration/shock). When fixing the lens, insulate the lens from the fixture.
- (2) The above specifications are values calculated from the optical design and can vary depending on installation conditions.

3-4-12 High-resolution Telecentric Lens for C-mount Lens for 1.1-inch Image Sensor (VS-TEV Series)

FH-S□X12, FH-S□21R, FH-S□04, and FH-S□02 are recommended.

Specification

Model	3Z4S-LE VS-TEV0305		3Z4S-LE VS-TEV05075		3Z4S-LE VS-TEV07510	
	Optical magnification	0.3x	0.5x	0.5x	0.75x	0.75xx

Model			3Z4S-LE VS-TEV0305		3Z4S-LE VS-TEV05075		3Z4S-LE VS-TEV07510	
Field of view (V x H) (mm)	FH-S □X12	1.1 inch equivalent	47.1 x 34.5	28.2 x 20.7	28.2 x 20.7	18.8 x 13.8	18.8 x 13.8	14.1 x 10.4
	FH-S □21R	1 inch equivalent	44.4 x 29.6	26.6 x 17.7	26.6 x 17.7	17.7 x 11.8	17.7 x 11.8	13.3 x 8.9
	FH-S□04	1 inch equivalent	37.5 x 37.5	22.5 x 22.5	22.5 x 22.5	15.0 x 15.0	15.0 x 15.0	11.3 x 11.3
	FH-S□02	2/3 inch equivalent	37.5 x 19.9	22.5 x 12.0	22.5 x 12.0	15.0 x 8.0	15.0 x 8.0	11.3 x 6.0
WD (mm) ^{*1}			221.5	125.8	173.2	133.9	133.9	114.0
Effective FNO			4.3	6.2	5.0	6.8	6.8	8.5
Depth of field (mm) ^{*2}			3.8	2.0	1.6	1.0	1.0	0.7
Resolution (μm) ^{*3}			9.59	8.39	6.71	6.10	6.10	5.69
TV distortion			0.03 %	-0.04 %	0.06 %	0.04 %	0.04 %	0.02 %
Maximum sensor size			1.1 inch					

*1. The working distance is the distance from the end of the lens to the sensor.

*2. The depth of field is calculated using a permissible circle of confusion diameter of 0.04 mm.

*3. The resolution is calculated using a wavelength of 550 nm.

3-4-13 Extension Tubes

Specification

Lenses	For M42 mount Lenses ^{*1}	For C mount Lenses ^{*1}	For Small Digital CCD Cameras
Model	3Z4S-LE VS-EXR/M42	3Z4S-LE SV-EXR	FZ-LESR
Contents	Set of 5 tubes (20 mm, 10 mm, 8 mm, 2 mm, and 1 mm) Maximum outer diameter: 47.5 mm dia.	Set of 7 tubes (40 mm, 20 mm, 10 mm, 5 mm, 2.0 mm, 1.0 mm, and 0.5 mm) Maximum outer diameter: 30 mm dia.	Set of 3 tubes (15 mm, 10 mm, 5 mm) Maximum outer diameter: 12 mm dia.

*1. Do not use the 0.5-mm, 1.0-mm, and 2.0-mm Extension Tubes attached to each other. Since these Extension Tubes are placed over the threaded section of the Lens or other Extension Tube, the connection may loosen when more than one 0.5-mm, 1.0-mm or 2.0-mm Extension Tube are used together. Reinforcement is required to protect against vibration when Extension Tubes exceeding 30 mm are used. When using the Extension Tube, check it on the actual device before using it.

3-4-14 Meaning of Optical Chart

Select lens appropriate for the camera. For more details, refer to *Vision Accessory Catalog (Cat. No. Q198)*.

How-to View the Optical Chart

The X axis of the optical chart shows the field of vision (mm)^{*1}, The Y axis of the optical chart shows the camera installation distance (mm) or WD^{*2}.

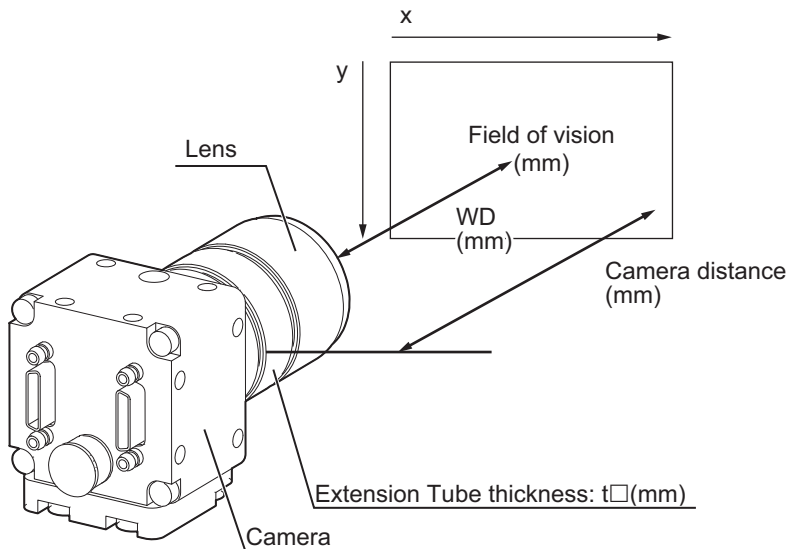

*1. The lengths of the fields of vision given in the optical charts are the lengths of the Y axis.

*2. The vertical axis represents WD for small cameras.

Optical Chart

● Normal Lenses

(a) Digital CCD Camera (Standalone): FZ-S□

High-speed Digital CCD/CMOS Camera (Standalone): FZ-SH□/ FH-S□

(Using 3Z4S-LE SV-V Series)

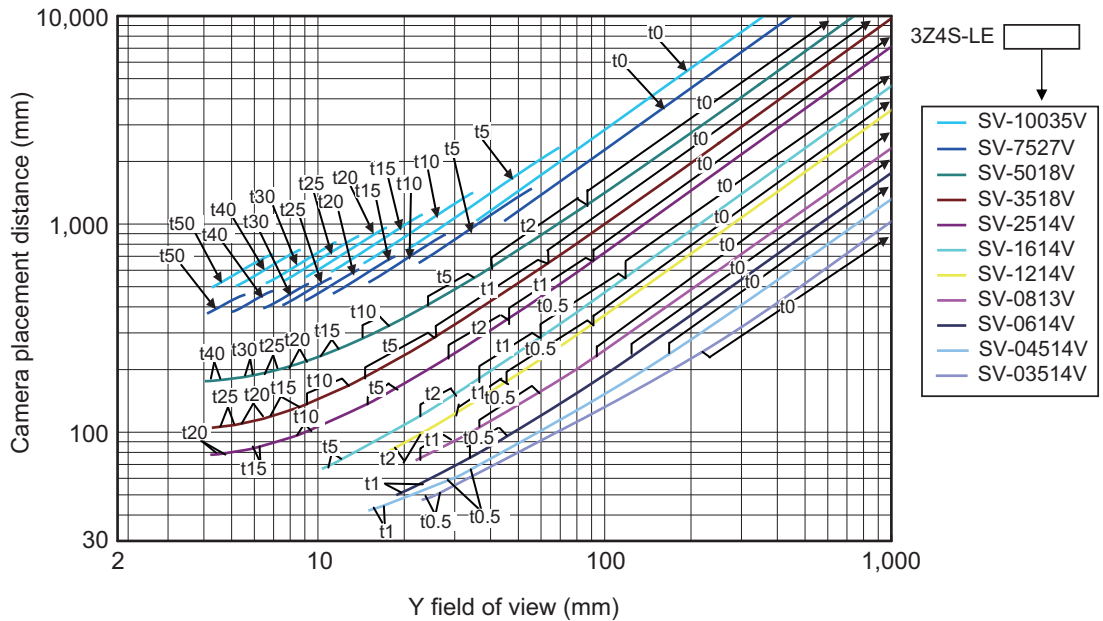

(b) Digital CCD Camera (Standalone): FZ-S□2M

(Using 3Z4S-LE SV-H Series)

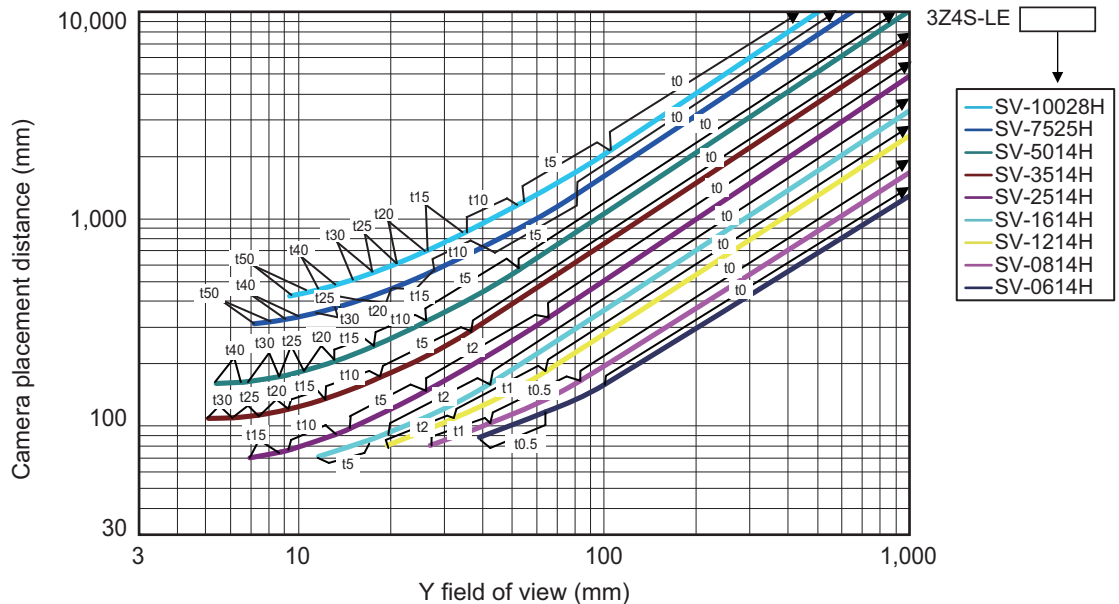

- (c) Digital CCD/CMOS Camera (Standalone): FZ-S5M2/FZ-S□5M3
 High-speed Digital CMOS Camera (Standalone): FH-S□X05
 (Using 3Z4S-LE SV-H Series)

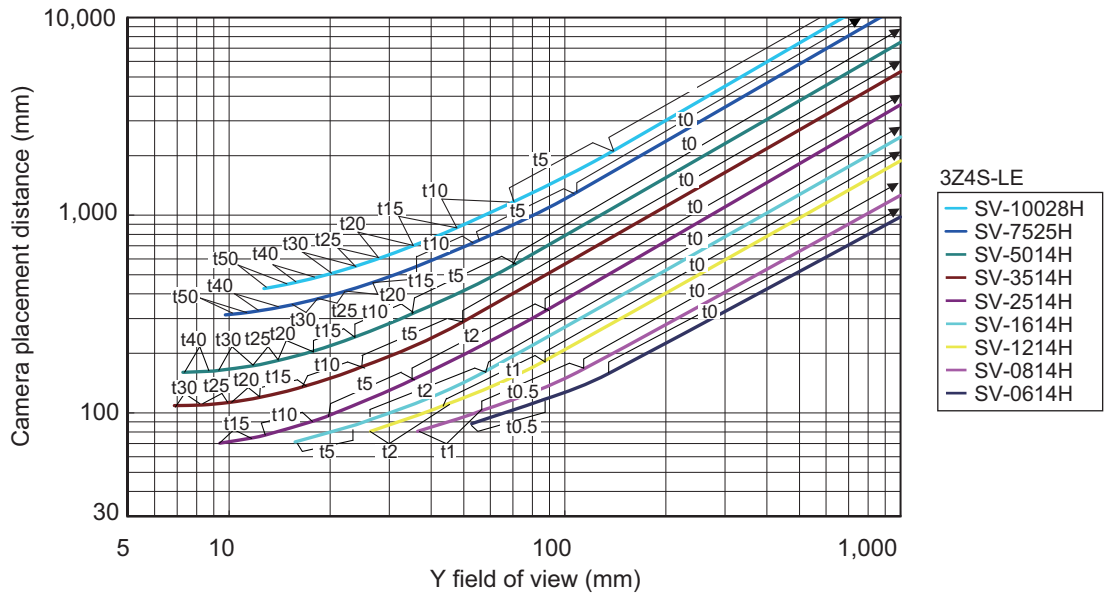

- (d) Digital CMOS Camera (Standalone): FH-S□05R
 (Using 3Z4S-LE SV-H Series)

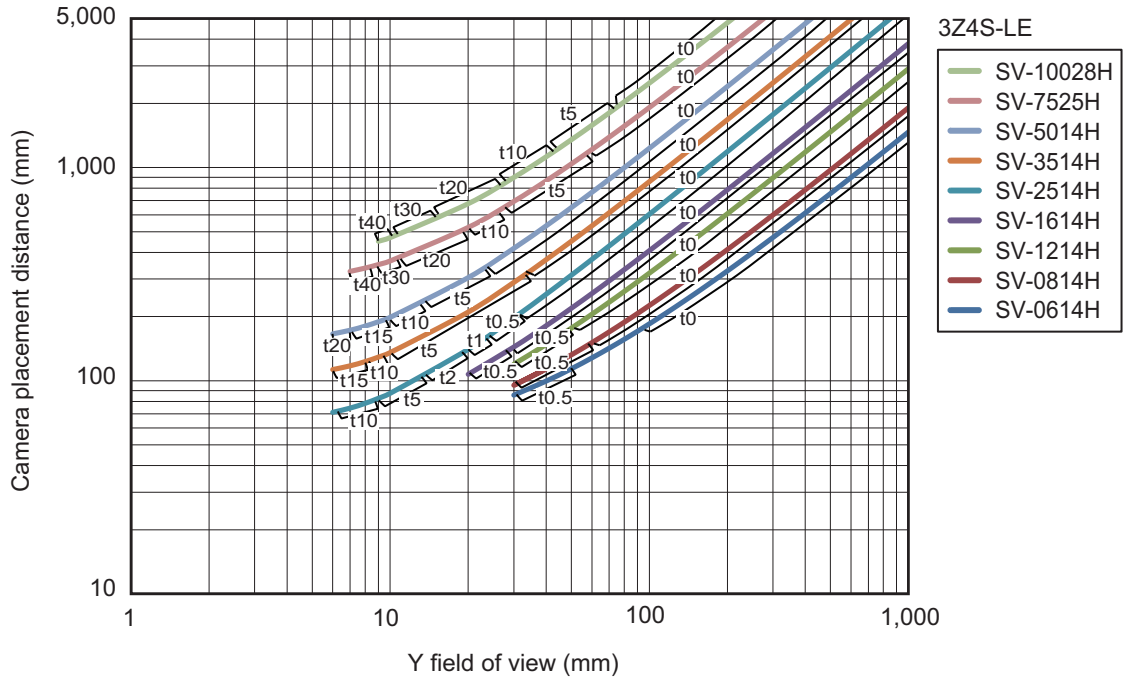

(e) Small Digital CCD Cameras (Standalone): FZ-SF□ or FZ-SP□ (Using FZ-LES Series)

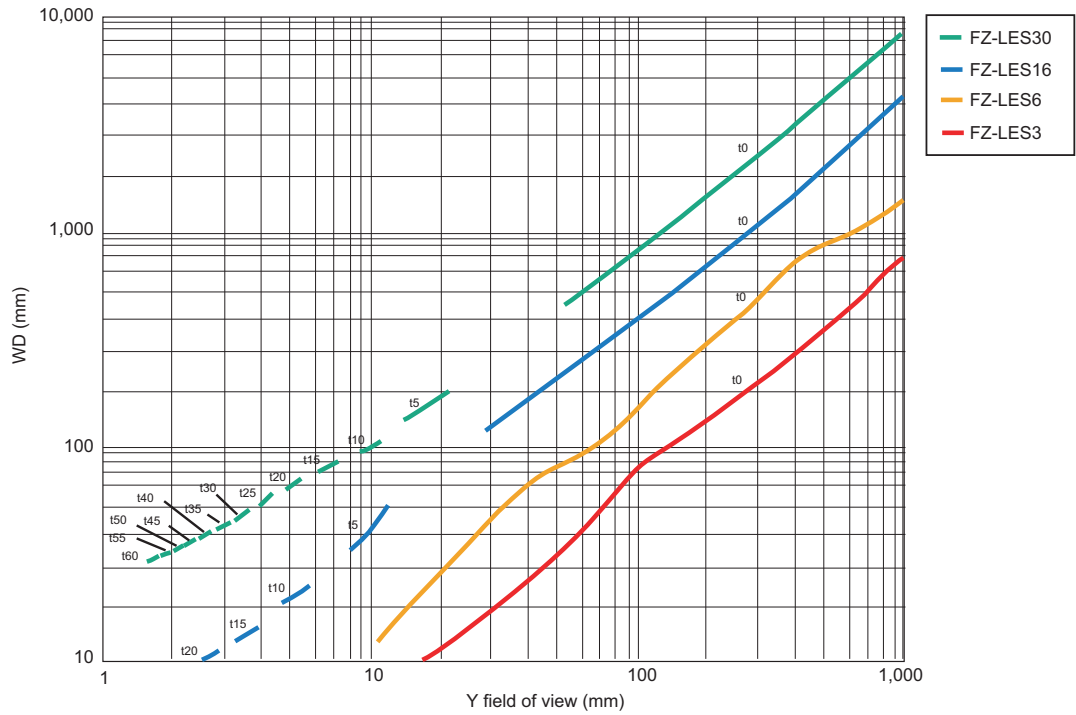

(f) High-speed Digital CMOS Camera (Standalone): FH-S□02 (Using 3Z4S-LE SV-H/VS-H1 Series)

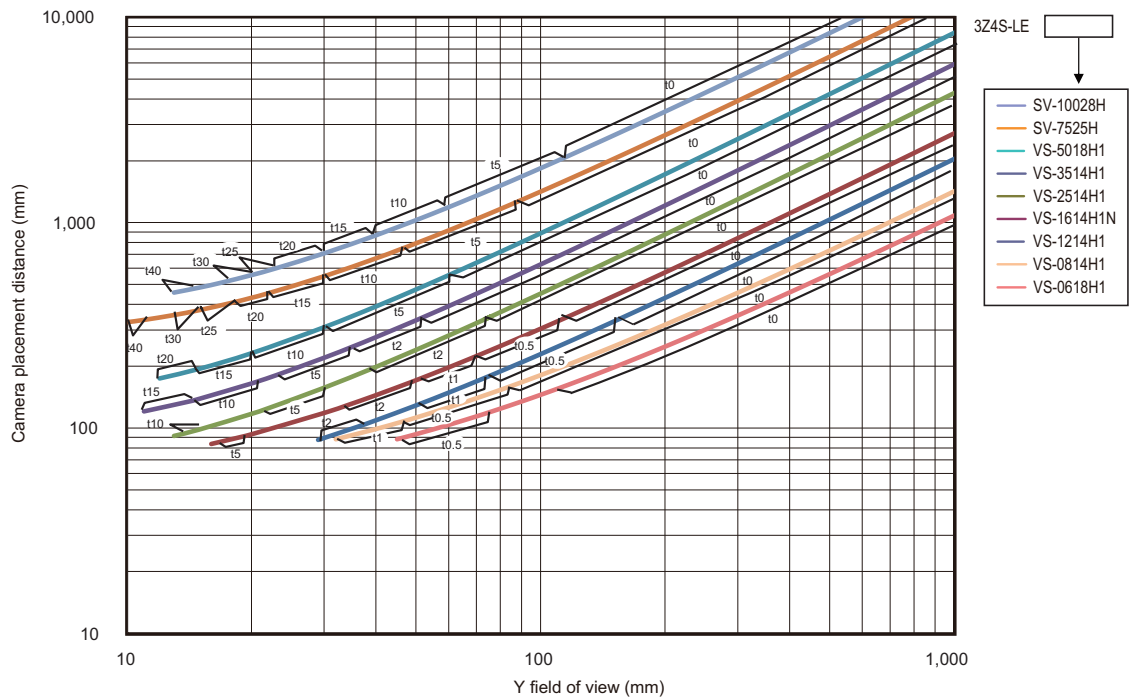

(g) High-speed Digital CMOS Camera (Standalone): FH-S□04
 (Using 3Z4S-LE SV-H/VS-H1 Series)

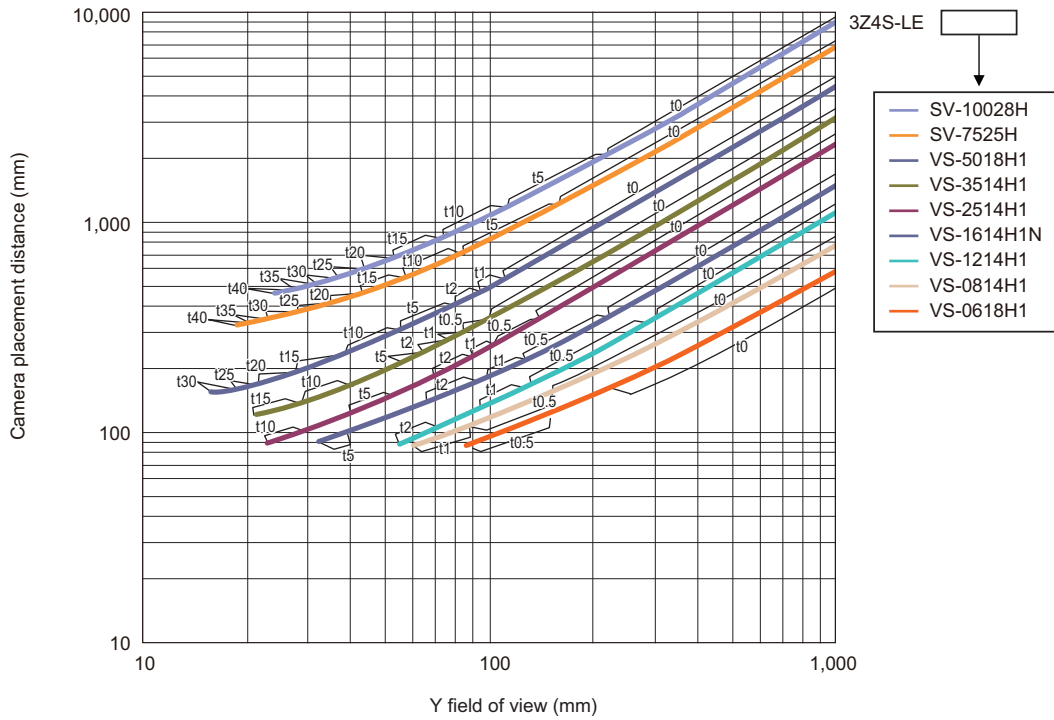

(h) High-speed Digital CMOS Camera (Standalone): FH-S□12
 (Using 3Z4S-LE VS-L/M42-10 Series)

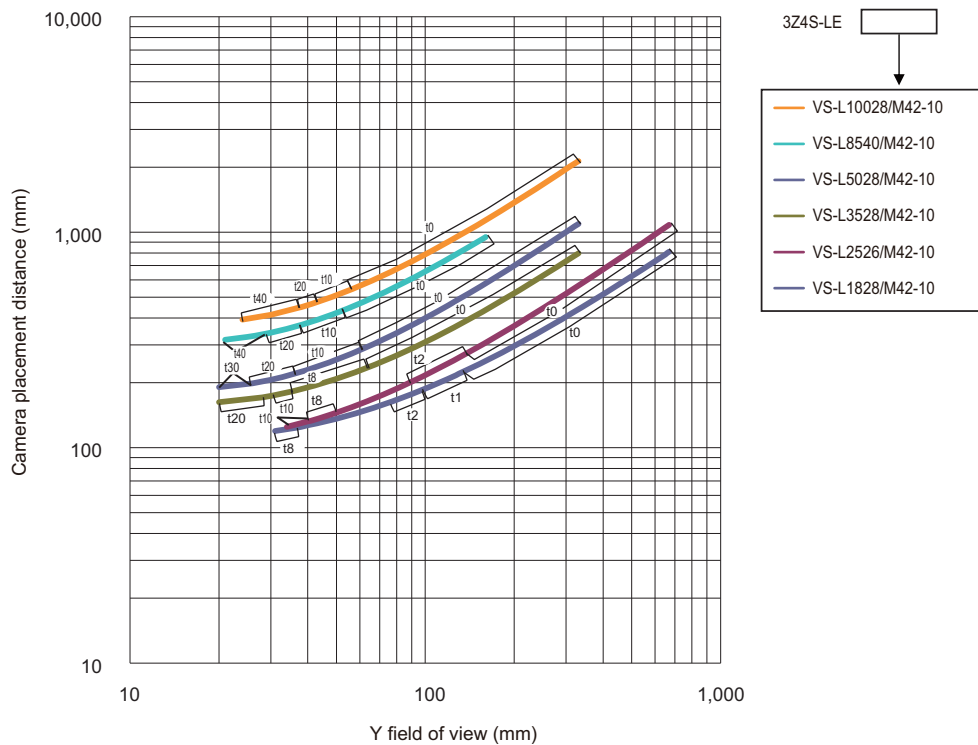

- (i) High-speed Digital CMOS Camera (Standalone): FH-S□X12
(Using 3Z4S-LE VS-LLD Series)

Note: The 3Z4S-LE VS-LDD Series cannot be used with an extension tube.

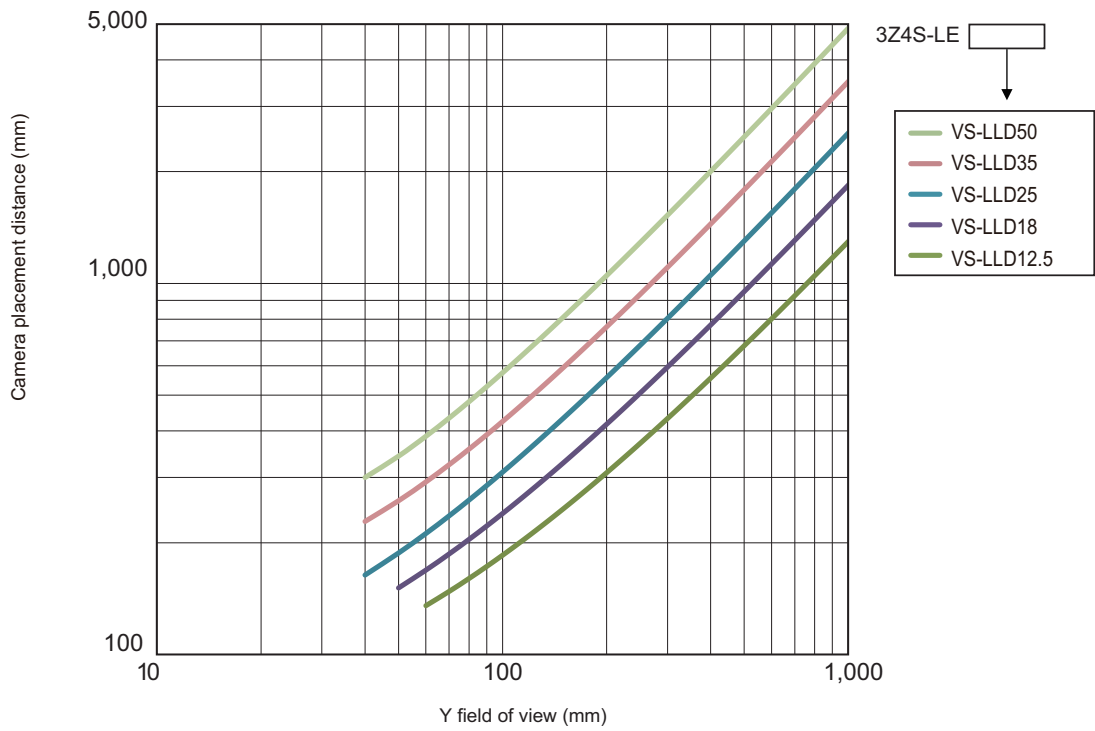

- (j) Digital CMOS Camera (Standalone): FH-S□21R
(Using 3Z4S-LE VS-LLD Series)

Note: The 3Z4S-LE VS-LDD Series cannot be used with an extension tube.

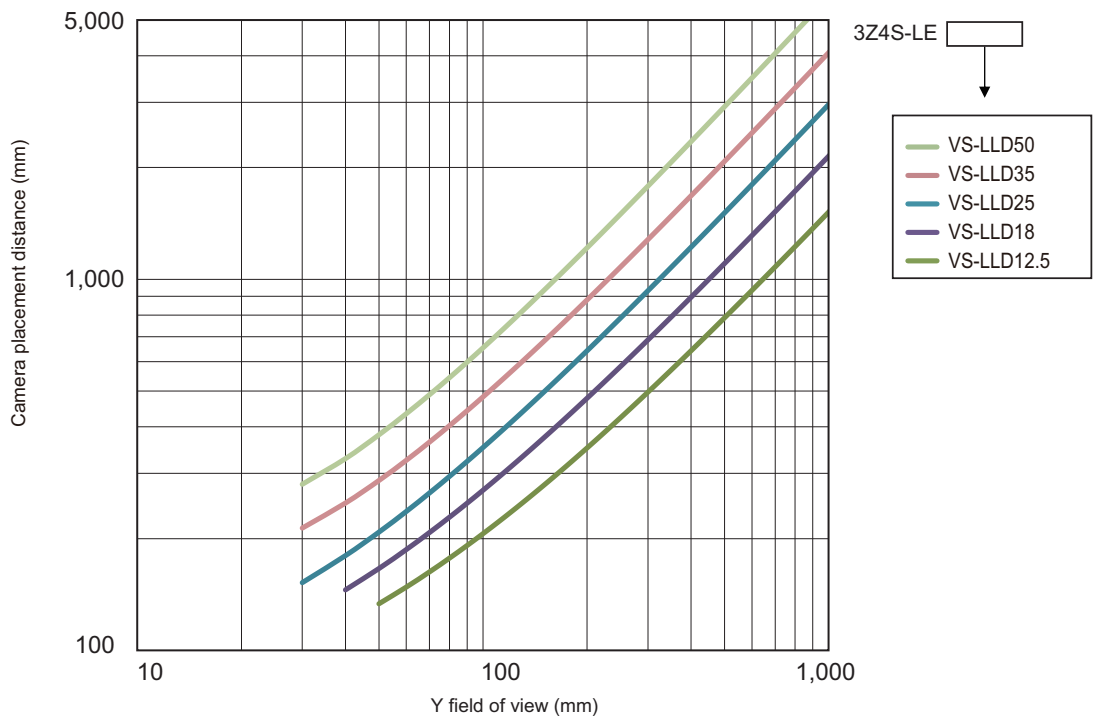

(k) High-speed Digital CMOS Camera (Standalone): FH-S□X
 (Using 3Z4S-LE SV-V Series)

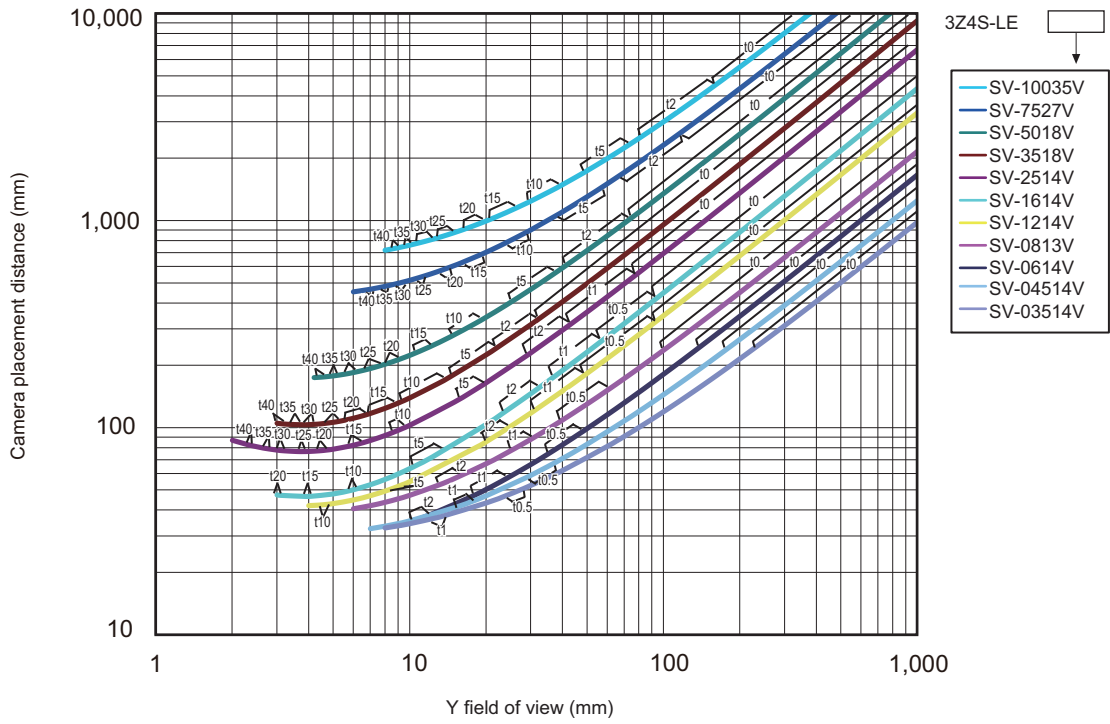

● **Vibration/Shock-resistance Lens**

- (a) Digital CCD Camera (Standalone): FZ-S□
 High-speed Digital CCD/CMOS Camera (Standalone): FZ-SH□/FH-S□
 (Using 3Z4S-LE VS-MC Series)

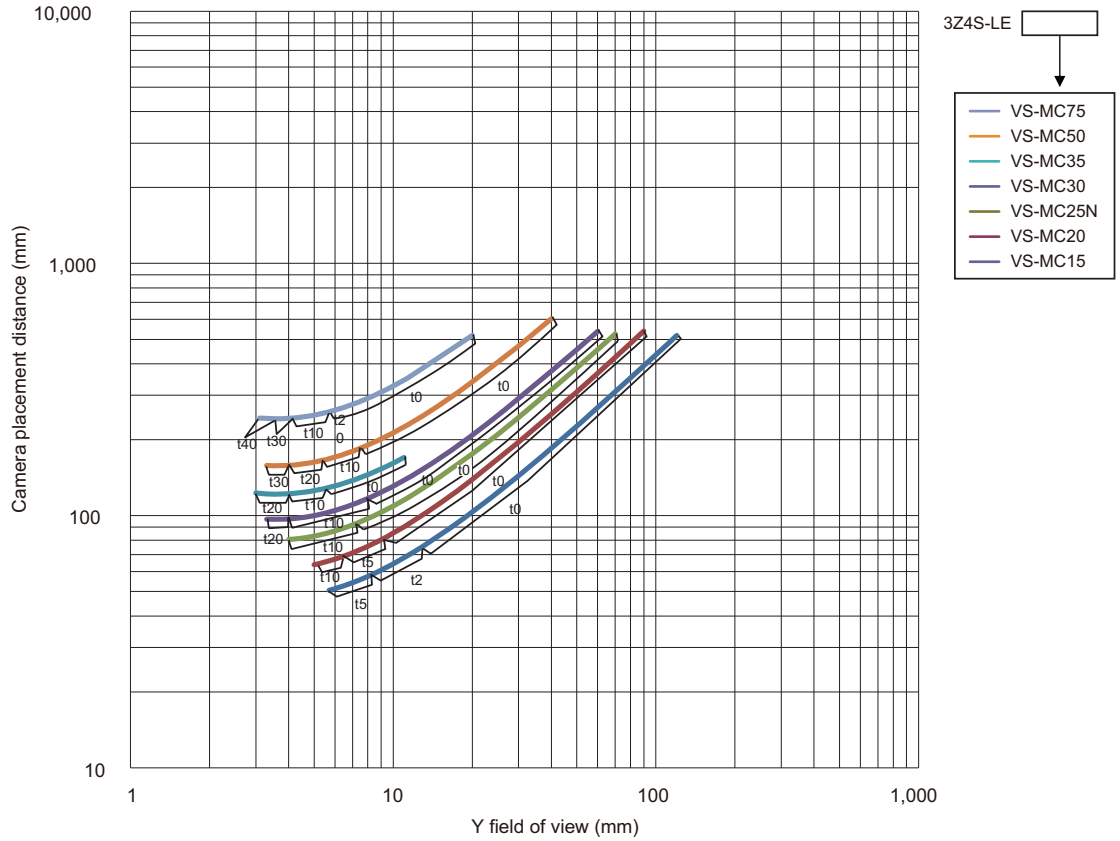

- (b) Digital CCD Camera (Standalone): FZ-S□
 High-speed Digital CCD/CMOS Camera (Standalone): FZ-SH□/FH-S□
 (Using 3Z4S-LE VS-MCA Series)

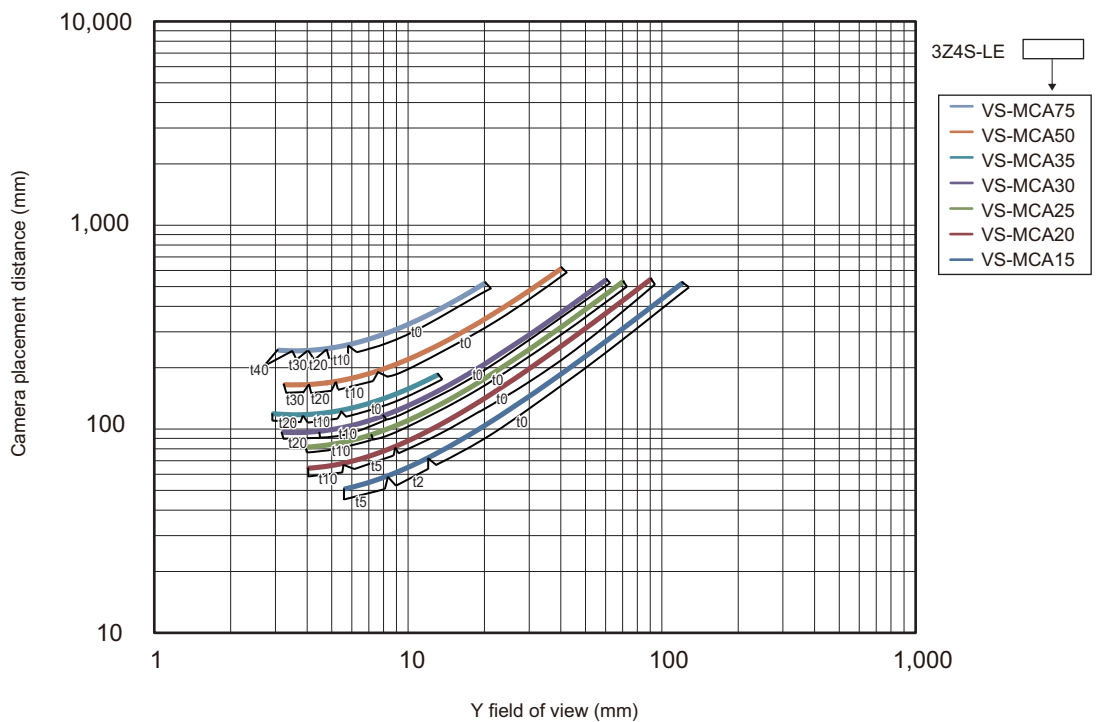

(c) High-speed Digital CMOS Camera (Standalone): FH-S□X
(Using 3Z4S-LE VS-MC Series)

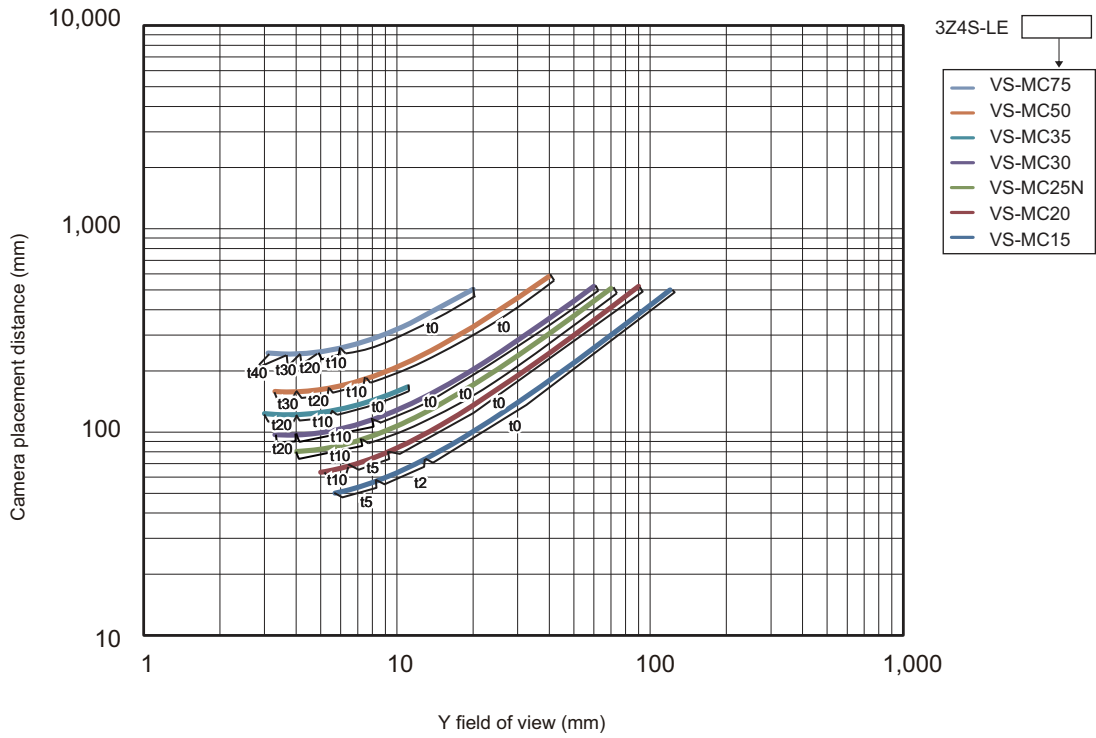

(d) High-speed Digital CMOS Camera (Standalone): FH-S□X
(Using 3Z4S-LE VS-MCA Series)

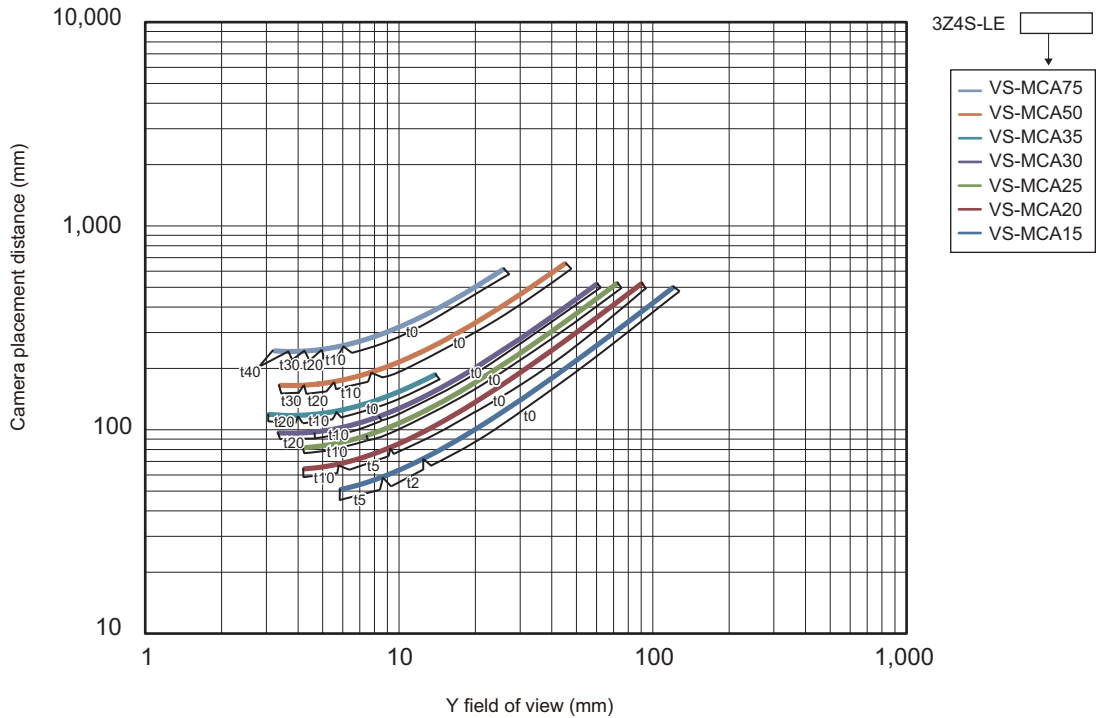

(e) Digital CCD Camera (Standalone): FZ-S□2M
(Using 3Z4S-LE VS-MC Series)

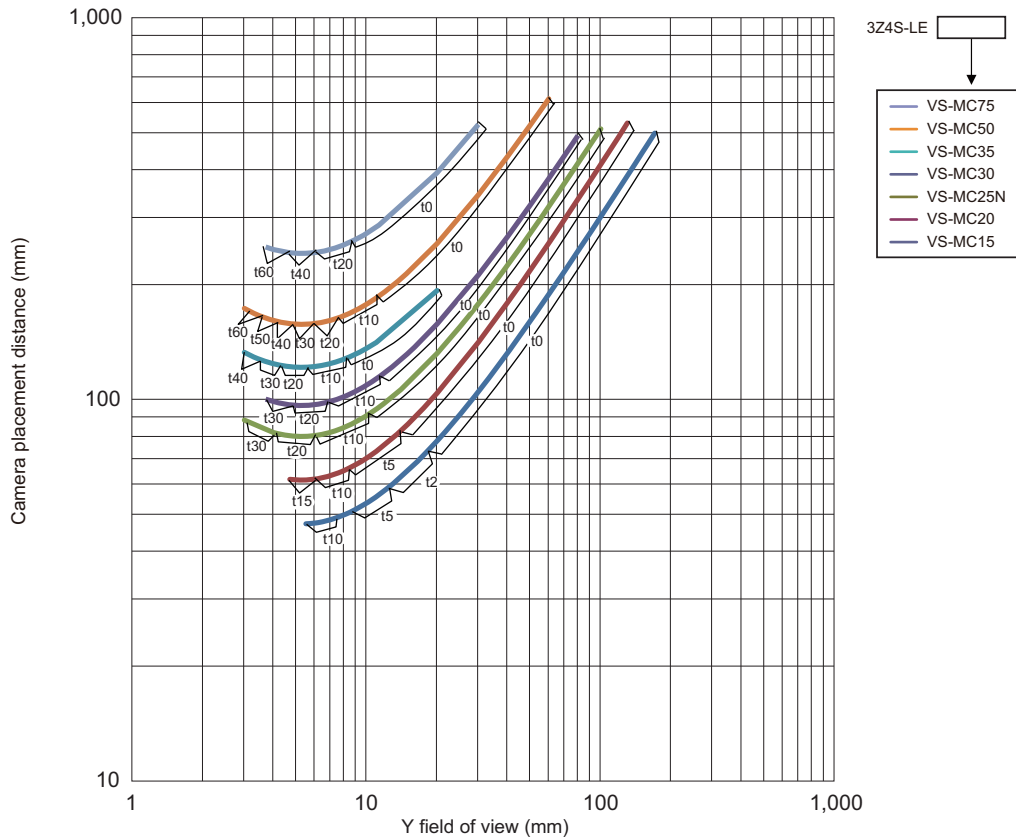

(f) Digital CCD Camera (Standalone): FZ-S□2M
(Using 3Z4S-LE VS-MCA Series)

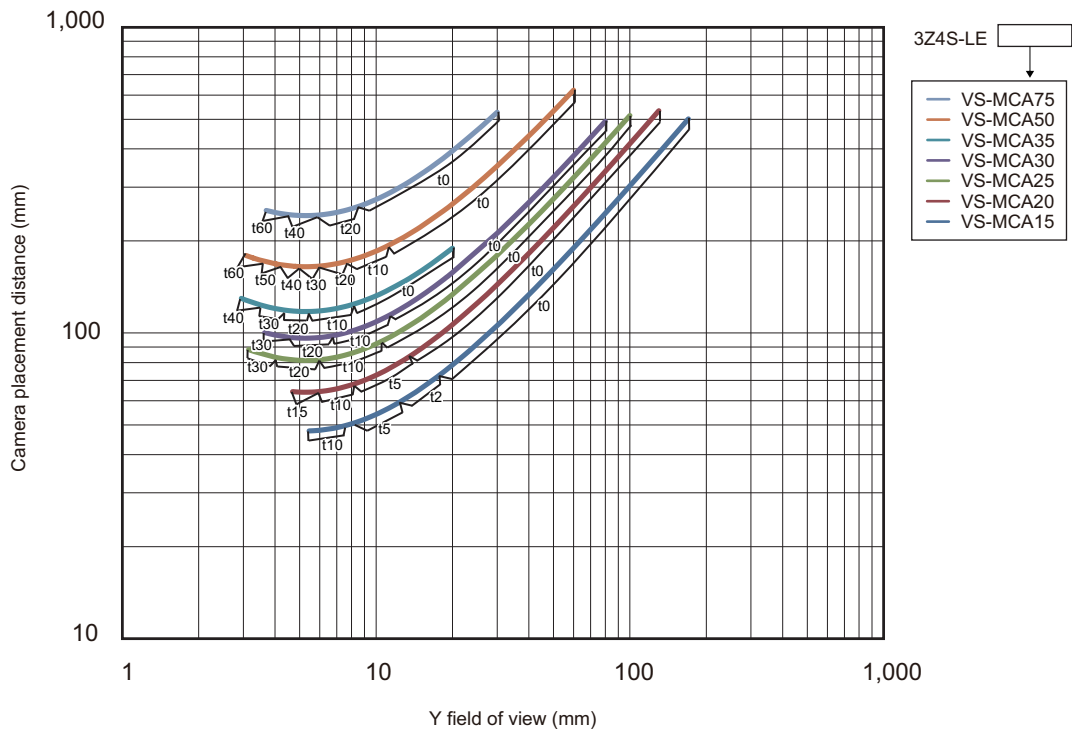

- (g) Digital CCD/CMOS Camera (Standalone): FZ-S5M2/FZ-S□5M3
 High-speed Digital CMOS Camera (Standalone): FH-S□X05
 (Using 3Z4S-LE VS-MC Series)

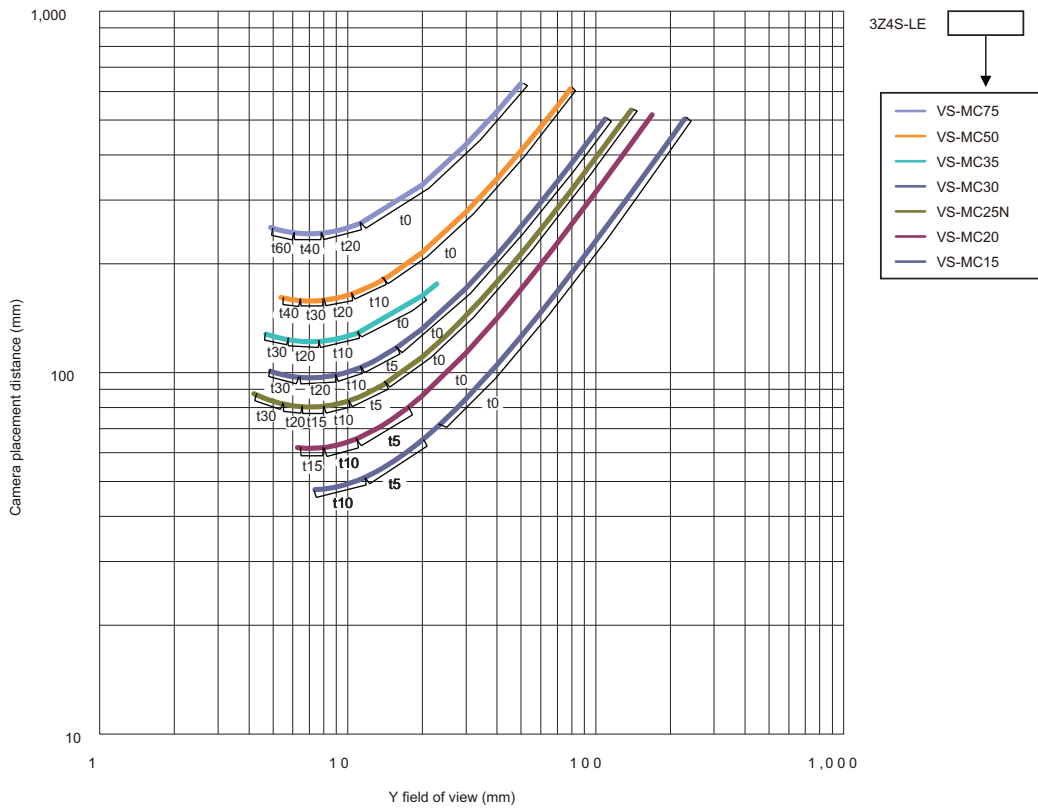

- (h) Digital CCD/CMOS Camera (Standalone): FZ-S5M2/FZ-S□5M3
 High-speed Digital CMOS Camera (Standalone): FH-S□X05
 (Using 3Z4S-LE VS-MCA Series)

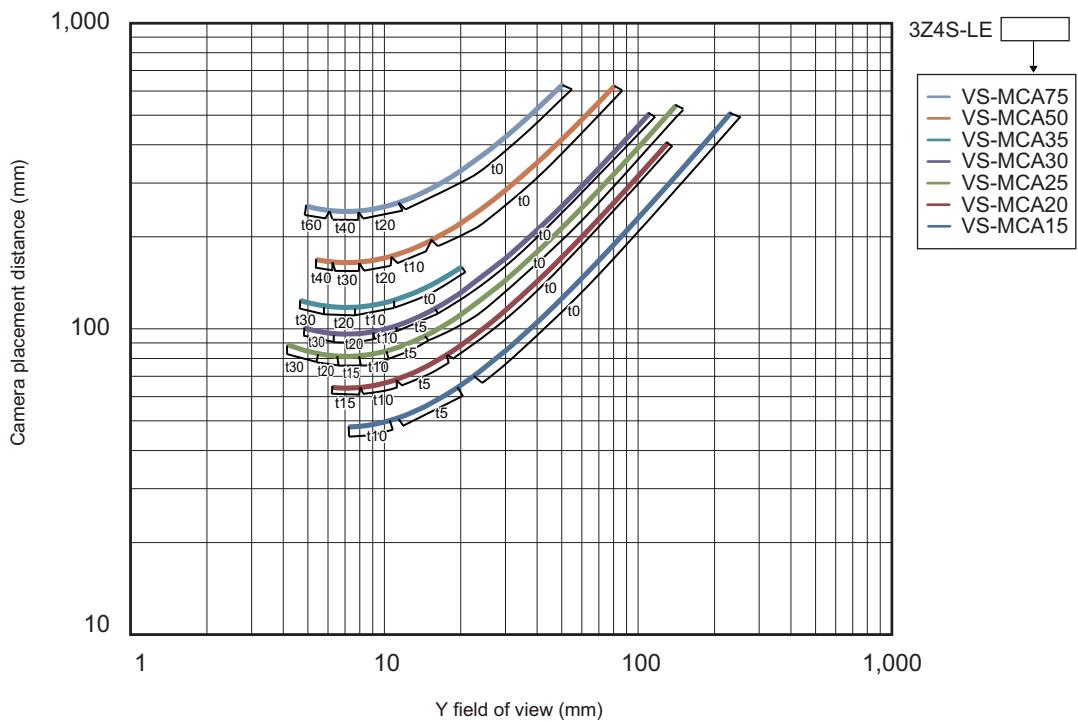

(i) Digital CMOS Camera (Standalone): FH-S□05R
(Using 3Z4S-LE VS-MC Series)

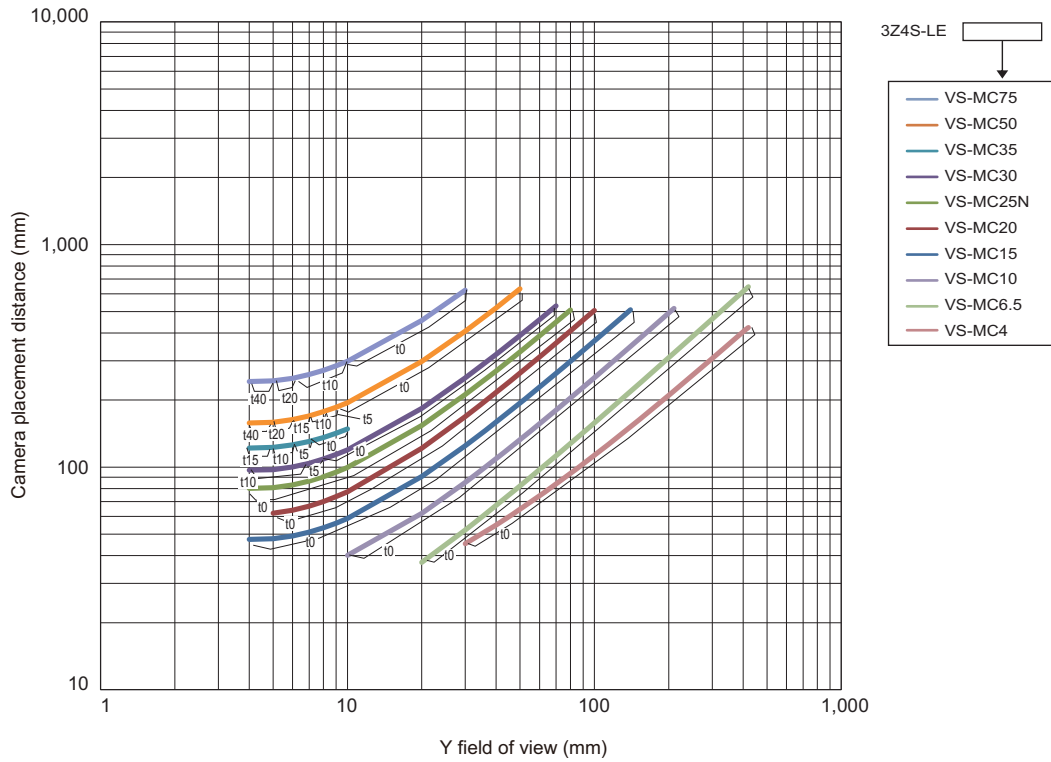

(j) Digital CMOS Camera (Standalone): FH-S□05R
(Using 3Z4S-LE VS-MCA Series)

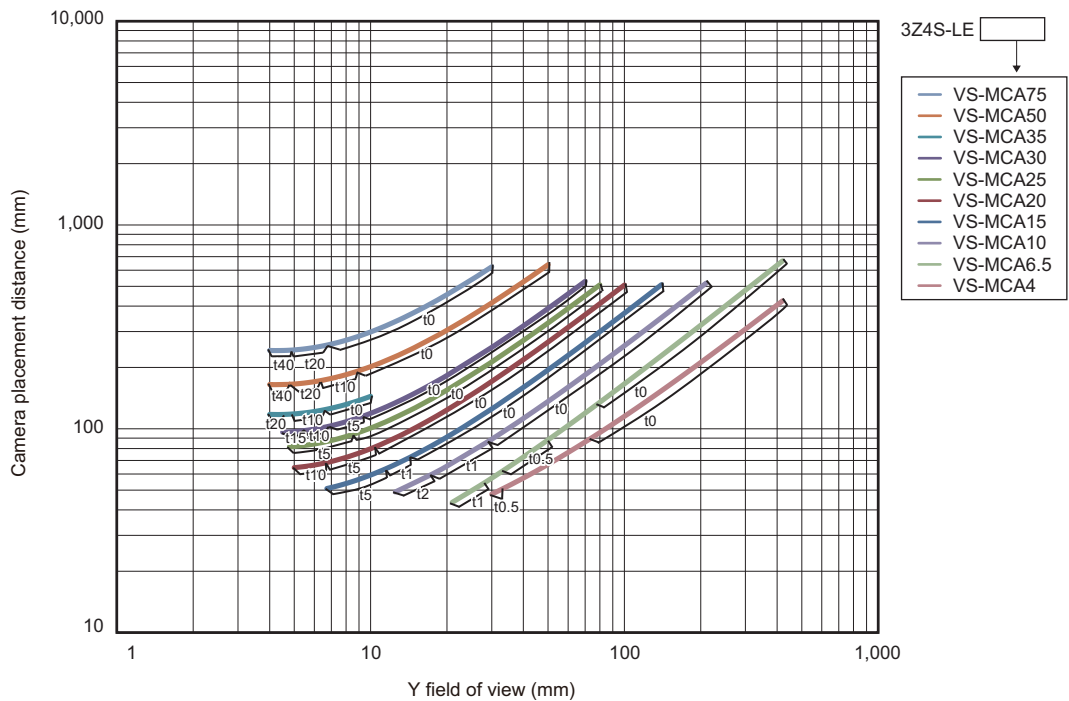

(k) High-speed Digital CMOS Camera (Standalone): FH-S□02
(Using 3Z4S-LE VS-MCH Series)

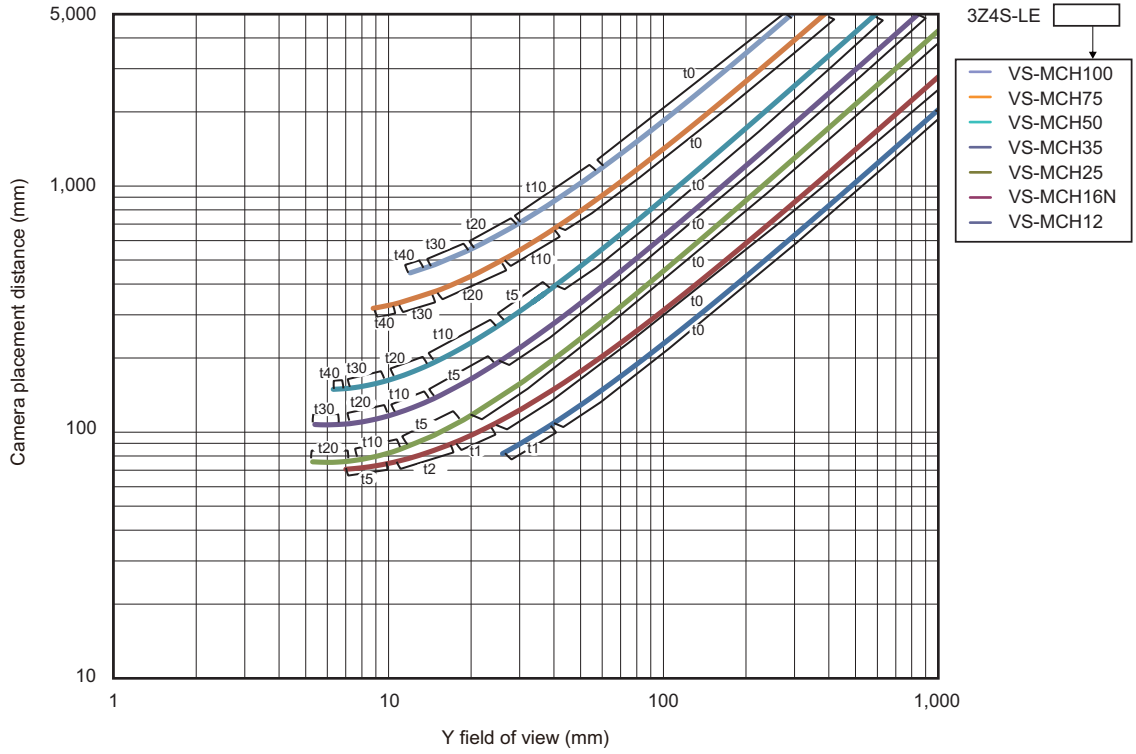

(l) High-speed Digital CMOS Camera: (Standalone): FH-S□04
(Using 3Z4S-LE VS-MCH Series)

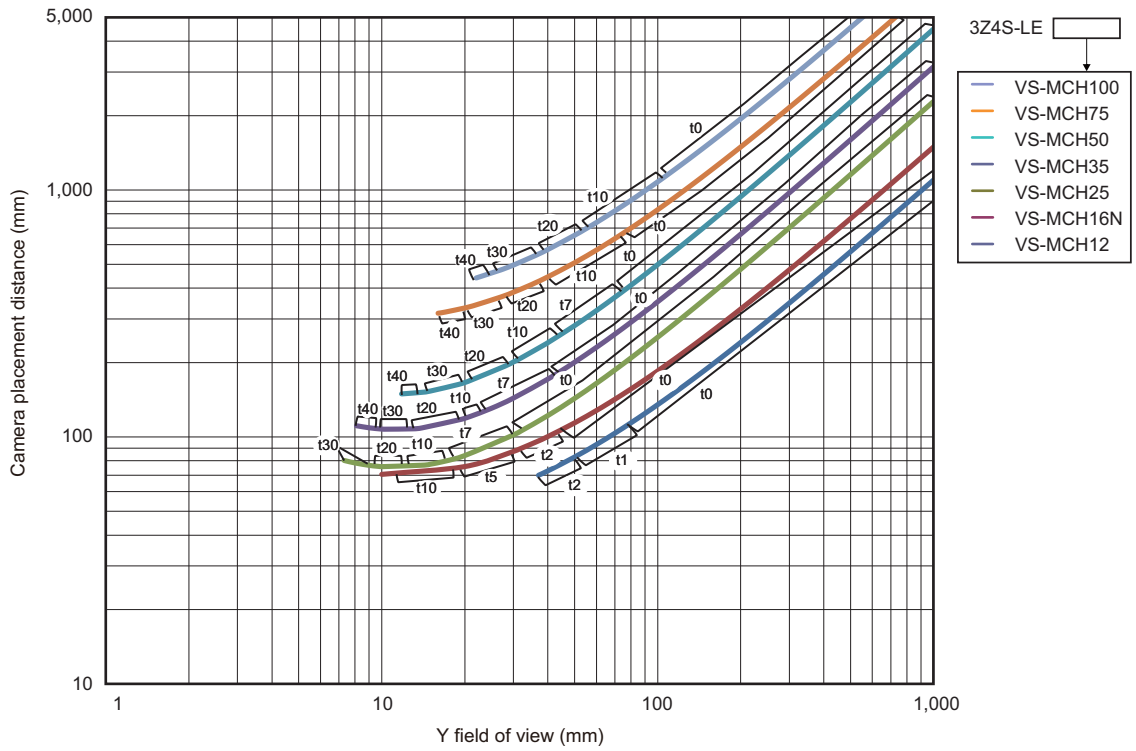

(m) Digital CMOS Camera (Standalone): FH-S□21R
(Using 3Z4S-LE VS-MCH Series)

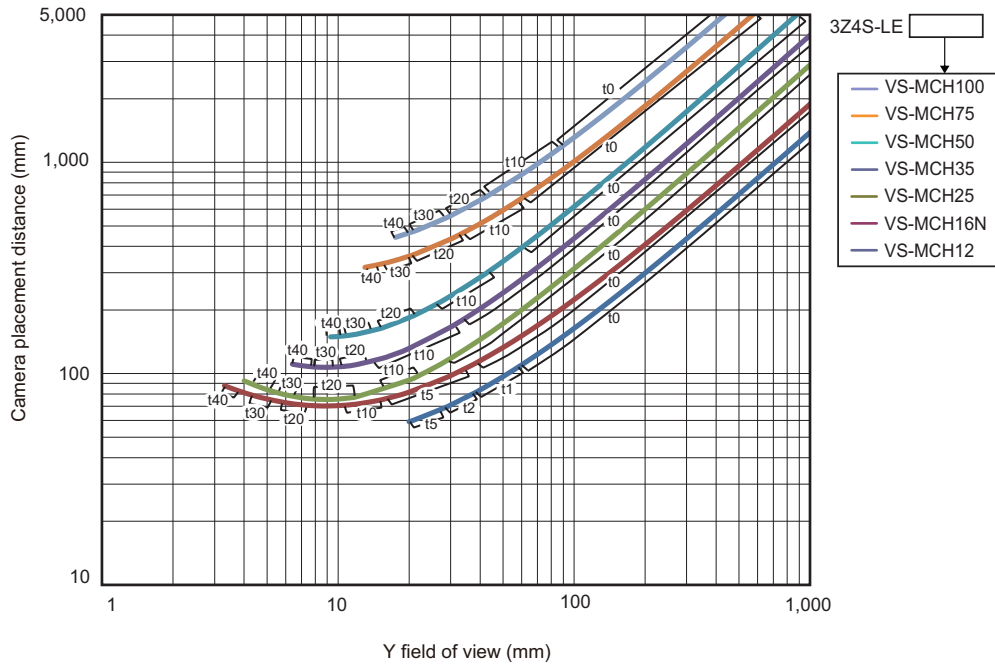

(n) High-speed Digital CMOS Camera (Standalone): FH-S□02
(Using 3Z4S-LE VS-MCH1 Series)

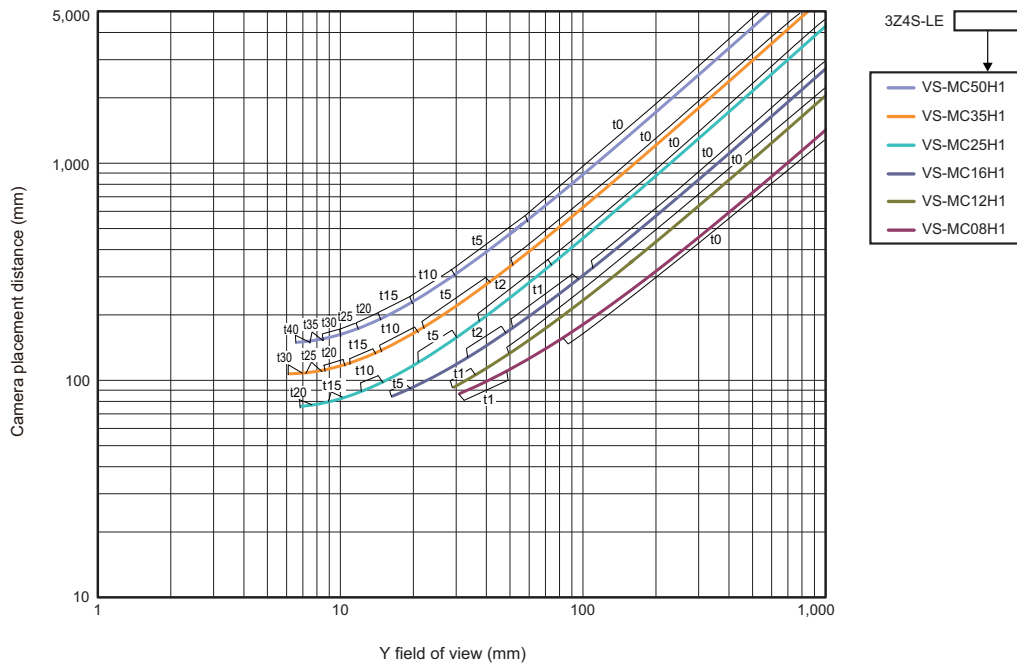

(o) High-speed Digital CMOS Camera: (Standalone): FH-S□04
(Using 3Z4S-LE VS-MCH1 Series)

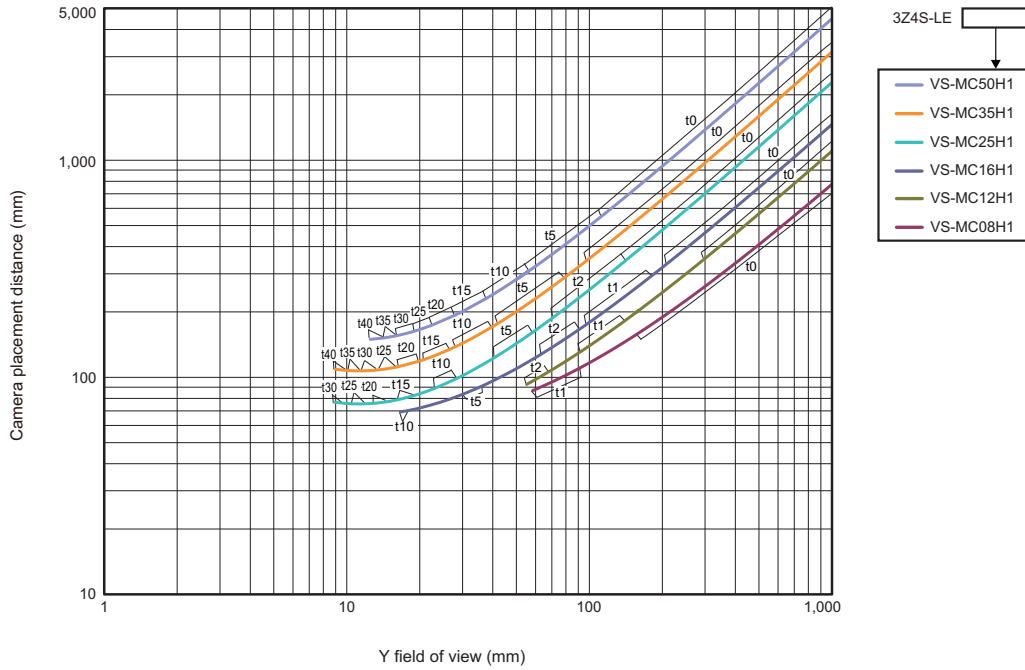

(p) Digital CMOS Camera (Standalone): FH-S□21R
(Using 3Z4S-LE VS-MCH1 Series)

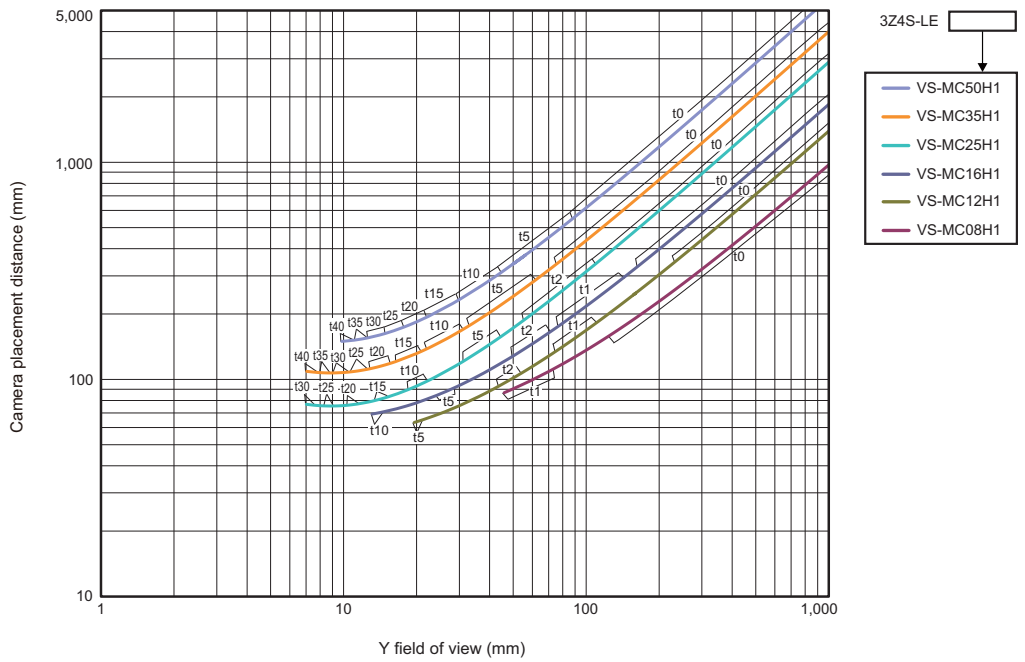

(q) High-speed Digital CMOS Camera (Standalone): FH-S□12
 (Using 3Z4S-LE VS-MCL/M42-10 Series)

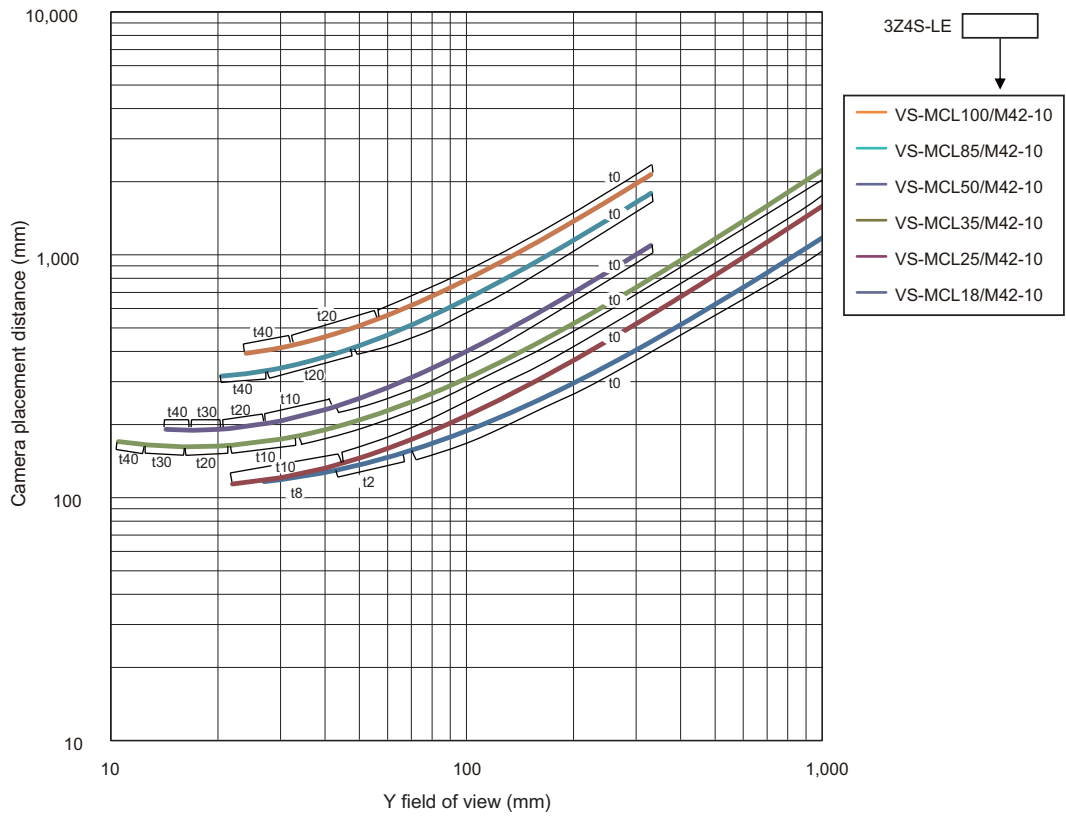

3-5 Touch Panel Monitor and Cable

Touch Panel Monitor of FH-MT12 is connectable with FH-1000/2000/3000/5000 and FH-L Sensor Controller whose software is Ver. 5.32 or later.

For connection of Touch Panel Monitor and FH Sensor Controller, the monitor cable for video and touch panel cable are necessary.



Precautions for Safe Use

About connection of Sensor Controller and FH-MT12.

- Do not ground the plus (+) terminal of the 24 VDC power source when the Sensor Controller is connected to the FH-MT12 with a USB cable. Doing so may cause a short circuit of the internal circuit, resulting in a malfunction.

Touch Panel Monitor

● Specification

	Model	FH-MT12
Major Function	Display area	12.1 inch
	Resolution	1024 (V) x 768 (H)
	Number of color	16,700,000 colors (8 bit/color)
	Brightness	500 cd/m ² (Typ)
	Contrast Ratio	600 : 1 (Typ)
	Viewing angle	Left and right: each 80°, upward: 80°, downward: 60°
	Backlight Unit	LED, edge-light
	Backlight lifetime	About 100,000 hour
	Touch panel	4 wire resistive touch screen
External interface	Video input	analog RGB
	Touch panel signal	USB, RS-232C
Ratings	Supply Voltage	24 VDC ±10 %
	Current consumption	0.5 A
	Insulation resistance	Between DC power supply and Touch Panel Monitor FG: 20 MΩ or higher (rated voltage 250 V)
Usage Environment	Ambient temperature range	Operating: 0 to +50°C, Storage: -20 to +65°C (with no icing or condensation)
	Ambient humidity range	Operating and Storage: 20 to 85% (with no icing or condensation)
	Ambient atmosphere	No corrosive gases
	Vibration tolerance	10 to 150 Hz, one-side amplitude 0.1 mm (Max. acceleration 15 m/s ²), 10 times for 8 minutes for each three direction
	Degree of protection	Panel mounting: IP65 on the front
Operation		Touch pen
Structure	Mounting	Panel mounting, VESA mounting
	Weight	Approx. 2.6 kg
	Case material	Front panel: PC/PBT, Front Sheet: PET, Rear case: SUS

Component Names and Functions

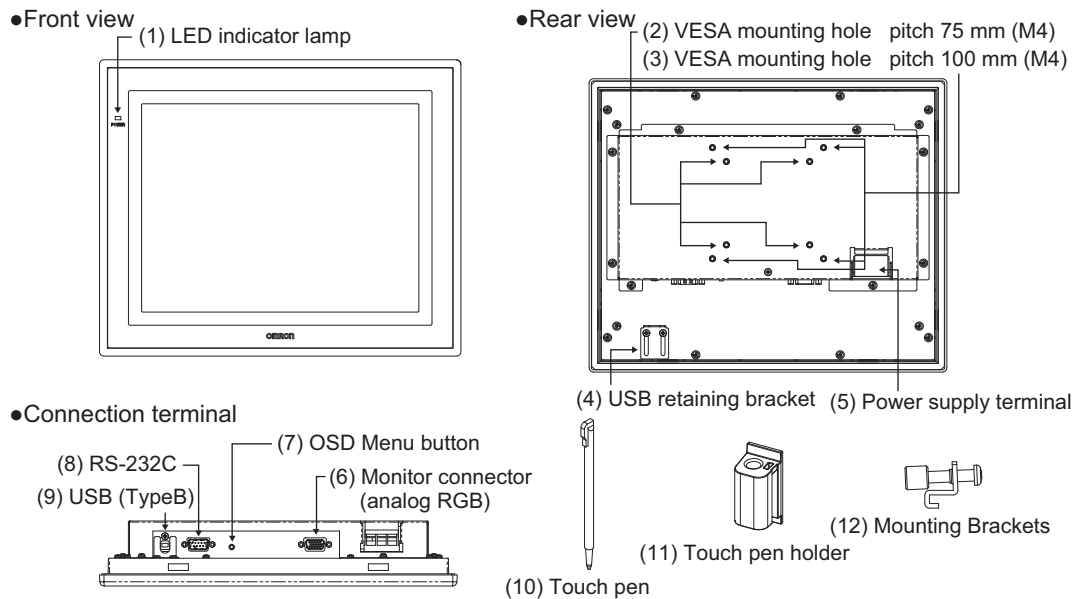

	Name	Description
(1)	LED indicator lamp	Lit up green when power is ON. Lit up orange when video signal is no input. Unlit when power is OFF.
(2)	VESA mounting hole (M4)	Mounting hole for VESA 75 mm x 75 mm.
(3)	VESA mounting hole (M4)	Mounting hole for VESA 100 mm x 100 mm.
(4)	USB retaining bracket	Retaining bracket for USB cable.
(5)	Power supply terminal	Connect a 24 VDC power supply.
(6)	Monitor connector (analog RGB)	Connect a monitor cable for analog RGB.
(7)	OSD Menu button	The button to activate the OSD menu.
(8)	RS-232C	Connect a serial communication port for touch panel communication.
(9)	USB (TypeB)	Connect a USB port (Type B) for touch panel communication.
(10)	Touch pen	Use for operation of touch panel.
(11)	Touch pen holder	Put touch pen in it when not using. Paste it on the monitor by double-sided tape.
(12)	Mounting Brackets	Use them to mount the panel.

For operation at launch OSD, refer to the Model FH-MT12 INSTRUCTION SHEET.

Touch Panel Monitor Cable

Normally, use the USB cable as a connection cable for Touch Panel Monitor.

Use the RS-232C cable as a connection cable for Touch Panel Monitor in the following cases.

- When Touch Panel Monitor is taken apart 5 m or more from FH Sensor Controller.
- When the USB port of the FH Sensor Controller is used for other I/O connection and cannot be used for Touch Panel communications.

● Specification

Model	FH-VMDA (2m)	FH-VUAB (2m)	XW2Z-200PP-1 (2m)
Cable type	DVI-Analog Conversion Cable	USB Cable	RS-232C Cable
Vibration (resistance)	10 to 150 Hz, Single amplitude 0.1 mm, 10 times for 8 minutes for each three direction		
Ambient temperature range	Operating Condition: 0 to +50°C, Storage Condition: -10 to +60°C (with no icing or condensation)		
Ambient humidity range	Operating and Storage: 35 to 85% (with no condensation)		
Ambient atmosphere	No corrosive gases		
Material	Cable outer sheath, Connector: PVC		Cable outer sheath: PVC, Connector: ABS/Ni Plating
Minimum bending radius	36 mm	25 mm	59 mm
Weight	Approx. 220g	Approx. 75g	Approx. 162g

Connection Example

● USB Connection (Cable Length Up to 5 m)

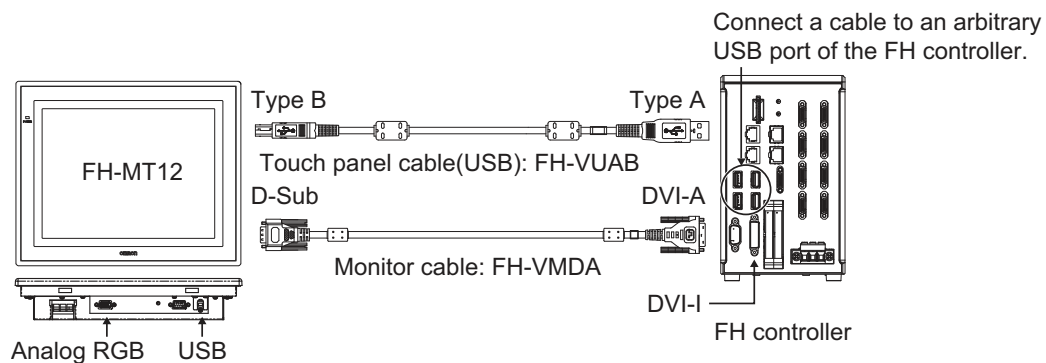

● RS-232C Connection (Cable Length Up to 10 m)

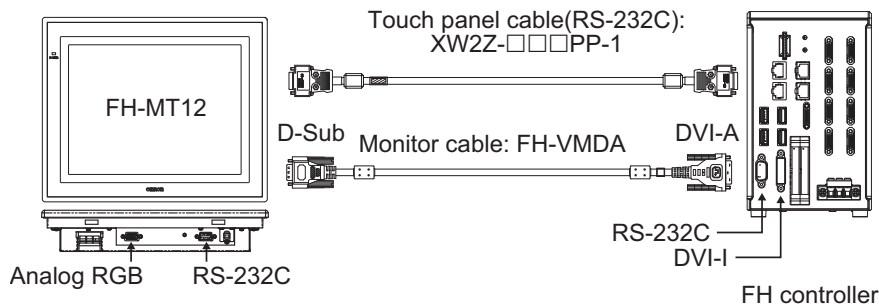

A video signal cable and an operation signal cable are required to connect the Touch Panel Monitor.

Signal	Cable	2 m	5 m	10 m
Video signal	DVI-Analog Conversion Cable	OK	OK	OK
Touch panel operation signal	USB Cable	OK	OK	-
	RS-232C Cable	OK	OK	OK

Wiring

The power terminal block for the Touch Panel Monitor is located on the back of it. Connect a power supply of 24 VDC there.

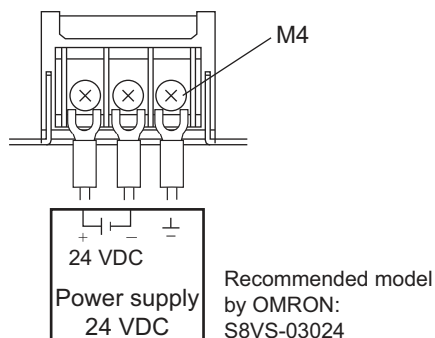

- Wire the power supply wires as short as possible. (Max.2 m)
- If UL's certification is required, use a UL class II power supply.
- Use the cables and crimping terminals with the specified dimensions.

Do not directly connect an electric wire that is simply twisted to the terminal block.

- Recommended wire size: AWG 13 to 22 (0.326 to 2.62 mm²)

- Terminal screw: M4 (Tightening torque: 1.0 N•m)

- Crimping Terminal

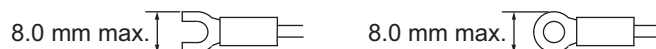

Dimensions

● Touch Panel Monitor

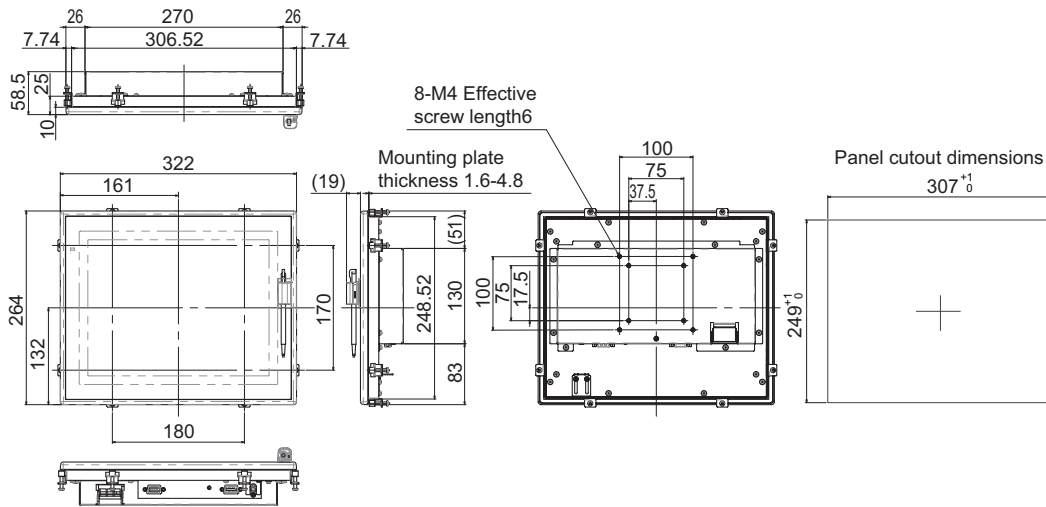

(Unit: mm)

Note:

1. Panel thickness: 1.6 to 4.8 mm
2. No burr allowed

● DVI-Analog Conversion Cable for Touch Panel Monitor: FH-VMDA

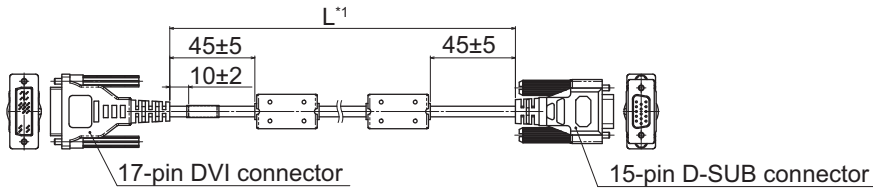

*1. Cable is available in 2 m/5 m/10 m.

(Unit: mm)

● RS-232C Cable for Touch Panel Monitor: XW2Z-□□□PP-1

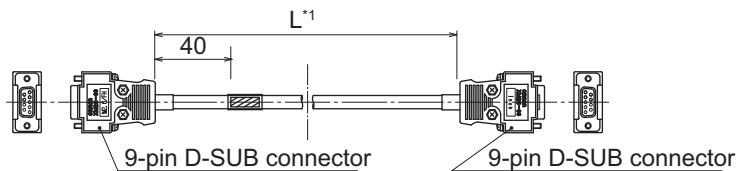

*1. Cable is available in 2 m/5 m/10 m.

(Unit: mm)

● **USB Cable for Touch Panel Monitor: FH-VUAB**

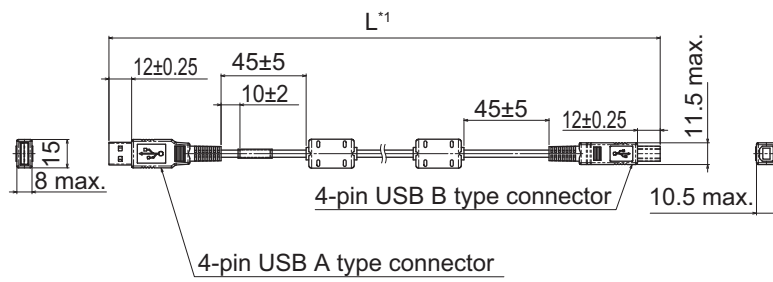

*1. Cable is available in 2 m/5 m.

(Unit: mm)

3-6 LCD and Cable

Specification

● LCD Monitor

Model	FZ-M08
Size	8.4 inches
Type	Liquid crystal color TFT
Resolution	1,024 x 768 dots
Input signal	Analog RGB video input 1 channel
Supply Voltage	21.6 to 26.4 VDC
Current consumption	Approx. 0.7 A max.
Ambient temperature range	Operating: 0 to +50°C, Storage: -25 to +65°C (with no icing or condensation)
Ambient humidity range	Operating and Storage: 35 to 85% (with no condensation)
Weight	Approx. 1.2kg
Accessories	Instruction Sheet and 4 mounting brackets

● LCD Monitor Cable

Model	FZ-VM
Vibration (resistance)	10 to 150 Hz, Single amplitude 0.15 mm, 3 directions, 8 strokes, 4 times
Ambient temperature range	Operation: 0 to +50°C, Storage: -20 to +65°C (with no icing or condensation)
Ambient humidity range	Operating and Storage: 35 to 85% (with no condensation)
Ambient atmosphere	No corrosive gases
Material	Cable sheath: heat-resistant PVC Connector: PVC
Minimum bending radius	75 mm
Weight	Approx. 170g



Precautions for Correct Use

Use the DVI-Analog Conversion Cable for Touch Panel Monitor: FH-VMDBA when connect the Sensor Controllers to the LCD monitor: FZ-M08. FZ-VM cable can use by combining the DVI-I - RGB Conversion Connector: FH-VMRGB.

Component Names and Functions

● Front View

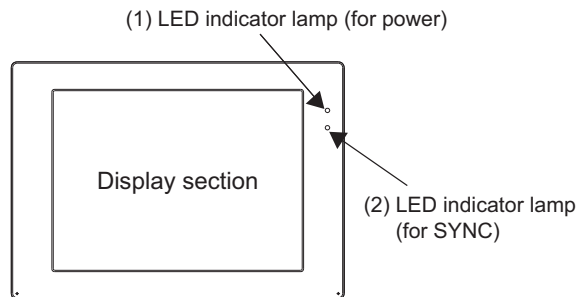

● Rear

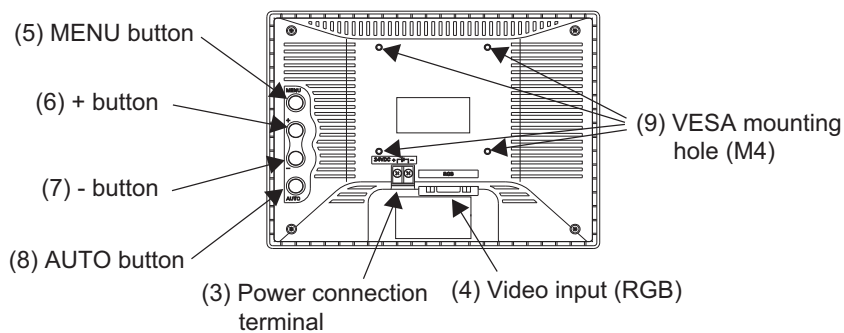

	Name	Description
(1)	LED indicator lamp (for power)	Lit up green when power is ON.
(2)	LED indicator lamp (for SYNC)	Lit up orange while the video signal is input.
(3)	Power supply terminal	Connect a 24 VDC power supply.
(4)	Video input (RGB)	Video input terminal (RGB)
(5)	MENU button	OSD operating button (MENU button)
(6)	+ button	OSD operating button (+ button)
(7)	- button	OSD operating button (- button)
(8)	AUTO button	OSD operating button (AUTO button)
(9)	VESA mounting hole (M4)	Mounting hole for VESA 75 mm x 75 mm.

Wire

The power terminal block for the Touch Panel Monitor is located on the back of it. Connect a power supply of 24 VDC there.

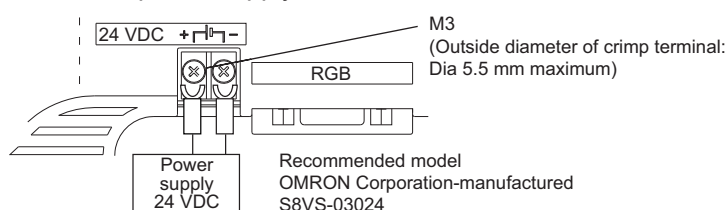

- Keep the power supply wires as short as possible (maximum 10 m).

- If UL recognition is required, use a UL class II power supply.
Regarding installation, do not use the VESA mounting but fix the monitor unit using the board mounting.

Dimensions

● LCD Monitor

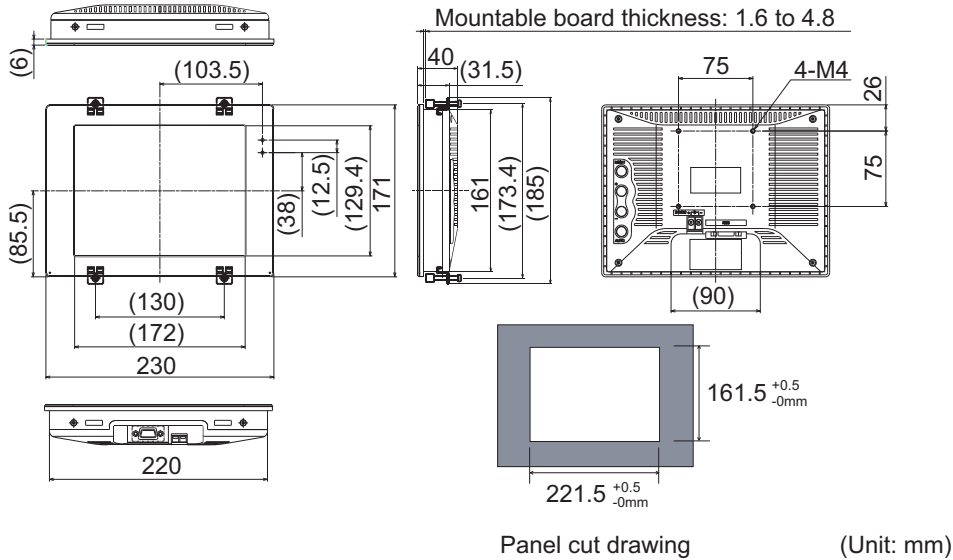

● Monitor Cable: FZ-VM

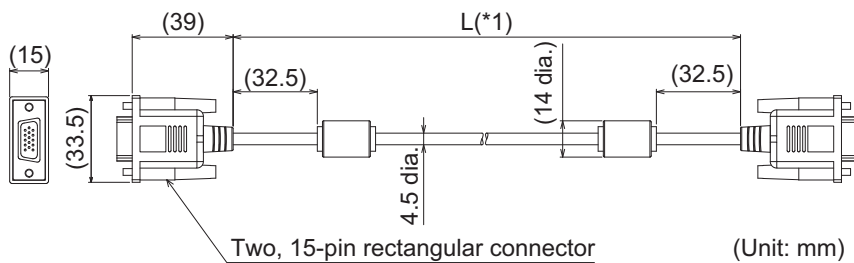

*1. Cable is available in 2 m/5 m.

● DVI-I -RGB Conversion Connector: FH-VMRGB

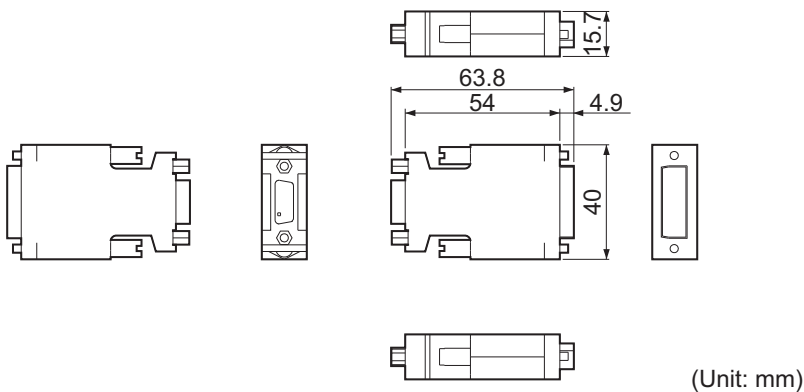

3-7 Sysmac Studio

When you connect the FH-1000/2000/3000/5000 Series and Sysmac Studio Standard Edition/Version Edition, use the latest version.

FH Series	Version of FH Series	Corresponding version of Sysmac Studio Standard Edition/Vision Edition
FH-5050(-□)	Ver.5.60	Supported by version 1.15 or higher.
FH-3050(-□)	Version 5.50	Supported by version 1.14.89 or higher.
FH-2050(-□)	Version 5.30	Supported by version 1.10.80 or higher.
FH-1050(-□)	Version 5.20	Supported by version 1.10 or higher.
	Version 5.10	Supported by version 1.07.43 or higher.
	Version 5.00	Supported by version 1.07 or higher. Not supported by version 1.06 or lower.

4

Handling and Installation Environment

4-1	All Series	4 - 2
4-2	FH-1000/2000/3000 Series	4 - 4
4-3	FH-L Series	4 - 5

4-1 All Series

WARNING

This product must be used according to this manual and Instruction Sheet. Failure to observe this may result in the impairment of functions and performance of the product.



This product is not designed or rated for ensuring the safety of persons. Do not use it for such purposes.



A lithium battery is built into the Controller and may occasionally combust, explode, or burn if not treated properly. Dispose of the Controller as industrial waste, and never disassemble, apply pressure that would deform, heat to 100°C or higher, or incinerate the Controller.



Precautions for Safe Use

Installation Environment

- Do not use the product in the environment with flammable or explosive gases.
- Install the product so that the air can flow freely through its cooling vents.
- Regularly clean the vent holes or fan outlet to prevent dust or particles blocking them. Internal temperature increases when those are blocked, it causes malfunction.
- To secure safety for operation and maintenance, install the product apart from high-voltage devices and power devices.
- Make sure to tighten all screws in mounting.

Handling of Sensor Controller

- Do not attempt to dismantle, repair, or modify the product.
- Do not drop the product nor apply excessive vibration or shock to the product. Doing so may cause malfunction or burning.
- This product is heavy. Be careful not to drop it while handling.
- When disposing of the product, treat it as an industrial waste.
- A lithium battery is incorporated, so a severe injury may rarely occur due to ignition or explosion.



Precautions for Correct Use

Installation and Storage Sites

Install and store the product in a location that meets the following conditions:

- No rapid changes in temperature (place where dew does not form)
- No presence of corrosive or flammable gases
- Place free of dust, salts and iron particles
- Place free of vibration and shock
- Place out of direct sunlight
- Place where it will not come into contact with water, oils or chemicals
- Place not affected by strong electro-magnetic waves
- Place not near to high-voltage, or high-power equipment
- Do not install the product immediately above significant heat sources, such as heaters, transformers, or large-capacity resistors.
- Do not install the Sensor Controller in a cabinet with high-voltage equipment installed. Mount the Sensor Controller at 200 [mm] or more from power cables apart.

Handling of Sensor Controller

- Touching Signal Lines:
When touching a terminal part or a signal wire in a connector, take anti-static measures using a wrist strap or another device to prevent damage from static electricity.
- Handling a USB Memory:
Before removing a USB memory device, make sure that data is not being read or written to them.
For a USB memory device, the memory device's LED flashes or lights while data is being read or written, so make sure that it is turned OFF before removing the memory.

Maintenance

- Lightly wipe off dirt with a soft cloth.
 - Do not use thinners or benzine.
 - Clean the lens with a lens-cleaning cloth or air brush.
 - Dirt on the image element must be removed using an air brush.
-

4-2 FH-1000/2000/3000 Series



Precautions for Correct Use

Ambient Temperature

- Install and store the product in a location that meets the following conditions:
 - Surrounding temperature of 0 to +50°C*¹ (-20 to +65°C in storage)
 - *1. FH-5000 Series: Surrounding temperature of 0 to 45°C
 - Relative humidity of between 35 to 85%
- Do not let the ambient temperature exceed 50°C (122°F).
- Provide a forced-air fan cooling or air conditioning if the ambient temperature is near 50°C (122°F) so that the ambient temperature never exceeds 50°C (122°F).

Orientation of Product

- For good heat dissipation, install the product only in the position shown below so as not to block the ventilation holes. Install the product so that the air can flow freely through its cooling vents.

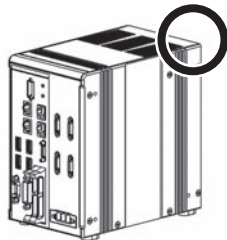

- Do not install the product in the following positions.

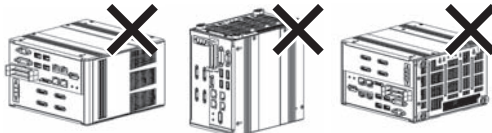

- For good ventilation, provide a clearance of 50 [mm] or more above the Sensor Controller away from other devices in the normal floor mounting. For the right and left sides, provide a clearance of 30 [mm] or more, and for the back side, 15 [mm] or more. These clearances are also required when mounting multiple Sensor Controllers side by side. For the back mounting, the back-side clearance of 15 [mm] is not required.

Handling a SD memory card

- Before removing a SD memory card, make sure that data is not being read or written to them.
- For SD memory card, the SD BUSY LED flashes or lights while data is being read or written, so make sure that it is turned OFF before removing the memory.
- Do not insert an SD memory card in the reverse orientation, at an angle, or in a twisting manner.

4-3 FH-L Series



Precautions for Correct Use

Ambient Temperature

- Install and store the product in a location that meets the following conditions:
 - Surrounding temperature of 0 to +55°C (-25 to +70°C in storage)
 - Relative humidity of between 10 to 90%
- Do not let the ambient temperature exceed 55°C (131°F).
- Provide a forced-air fan cooling or air conditioning if the ambient temperature is near 55°C (131°F) so that the ambient temperature never exceeds 55°C (131°F).

Orientation of Product

- For good heat dissipation, install the product only in the position shown below so as not to block the ventilation holes.

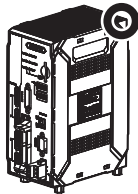

- Do not install the product in the following positions.

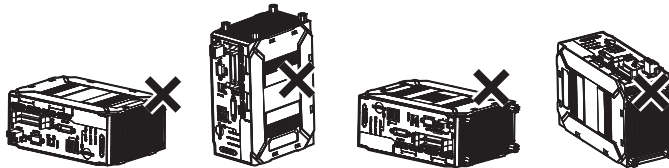

- For good ventilation, provide a clearance of 50 mm or more above the Sensor Controller away from other devices in the normal floor mounting. For the right and left sides, back side, for other devices, or Sensor Controller 25 mm or more.

Handling SD memory card

- Before removing a SD memory card, make sure that data is not being read or written to them.
- For SD memory card, the SD BUSY LED flashes or lights while data is being read or written, so make sure that it is turned OFF before removing the memory.
- Do not insert an SD memory card in the reverse orientation, at an angle, or in a twisting manner.

5

Setup and Wiring

5-1	When turning ON and OFF	5 - 2
5-1-1	All Series.....	5 - 2
5-1-2	FH-1000/2000/3000/5000 Series.....	5 - 3
5-1-3	FH-L Series.....	5 - 3
5-2	Fail-Safe Measures.....	5 - 4
5-3	Sensor Controller Installation.....	5 - 5
5-3-1	All Series.....	5 - 5
5-3-2	FH-1000/2000/3000/5000 Series.....	5 - 5
5-3-3	FH-L Series.....	5 - 11
5-4	Setup Touch Panel Monitor or Monitor	5 - 20
5-4-1	All Series.....	5 - 20
5-4-2	FH-1000/2000/3000/5000 Series.....	5 - 20
5-4-3	FH-L Series.....	5 - 20
5-5	Camera Installation	5 - 22
5-5-1	All Series.....	5 - 22
5-5-2	FH-1000/2000/3000/5000 Series.....	5 - 23
5-5-3	FH-L Series.....	5 - 24
5-6	Insert/Remove SD Memory Card or USB memory	5 - 25
5-6-1	Common in all series	5 - 25
5-7	Use by Connecting Software	5 - 26
5-7-1	Sysmac Studio FH Tool	5 - 26
5-7-2	FZ_FH Remote Operation Tool.....	5 - 26
5-7-3	Simulation Software	5 - 26
5-8	Installation in a Control Panel.....	5 - 27
5-8-1	All Series.....	5 - 27
5-8-2	FH-1000/2000/3000/5000 Series.....	5 - 29
5-8-3	FH-L Series.....	5 - 31

5-1 When turning ON and OFF

5-1-1 All Series

WARNING

Never connect the AC power supply with this product. When the AC power supply is connected, it causes the electric shock and a fire.



Do not touch the terminals while the power supply is ON. Doing so may result in electrical shock.



Caution

Please take fail-safe measures on your side in preparation for an abnormal signal due to signal conductor disconnection and/or momentary power interruption. An abnormal operation may result in a serious accident.



Precautions for Safe Use

- Check the following again before turning on the power.
 - Are the voltage and polarity of the power supply correct? (24 VDC)
 - Is the load of the output signal not short-circuited?
 - Is the load current for the output signal within the specified range?
 - Are there no wrong wirings?
- While the power is ON or immediately after the power is turned OFF, the Sensor Controller and camera case are still hot. Do not touch the case.
- Make sure to turn off the power when attach or detach cameras or cables. Connecting cables while the power is supplied may cause malfunction or damage to cameras or peripheral devices.
- Illumination is normal immediately after the power supply is turned ON. Do not look directly into the illumination light.
- After confirming that the product is started up, communicate with the high-order device.
- Should you notice any abnormalities, immediately stop use, turn OFF the power supply, and contact your OMRON representative.



Precautions for Correct Use

Turning OFF the Power

When a message is displayed indicating that a task is in progress, do not turn OFF the power. Doing so causes the data in the memory to be corrupted, resulting in the product not operating properly upon the next start-up.

Do not turn OFF during saving data to Sensor Controller.

When turns OFF, conform the followings proceedings have completed. and then operate again.

- When saves using Sensor Controller: Confirm the save processing is completed and next operation is possible.
- When saves using communication command: Intended command is completed. BUSY signal is turned OFF.

Maintenance

Turn OFF the power and ensure the safety before maintenance.

5-1-2 FH-1000/2000/3000/5000 Series



Precautions for Safe Use

- Check the following again before turning on the power.
Are the voltage value and polarity of the power supply that is provided to the encoder cable (ENC0 VDD/GND, ENC1 VDD/GND) correct? (5 VDC)
 - Check the wiring again before turning on the power.
-

5-1-3 FH-L Series



Precautions for Safe Use

Check the following again before turning on the power.

- Is the voltage and polarity of the power source set correctly? (24 VDC for positive terminal. 0 VDC for negative terminal.)
 - Make sure to connect the earth (FG) only to the grounding terminal.
-

5-2 Fail-Safe Measures

The fail-safe measures are the same for each series. Confirm the following instructions.

WARNING

Please take external safety measures so that the system as a whole should be on the safe side even if a failure of a Sensor Controller or an error due to an external factor occurred. An abnormal operation may result in serious accident.



Please take fail-safe measures on your side in preparation for an abnormal signal due to signal conductor disconnection and/or momentary power interruption.



Precautions for Safe Use

- Be sure to take fail-safe measures externally when controlling stages and robots by using the measurement results of the Sensor Controller (axis movement output by calibration and alignment measurement).



Precautions for Correct Use

Fail-Safe Measures

- Be sure to take fail-safe measures externally when controlling stages and robots by using the measurement results of the Sensor Controller (axis movement output by calibration and alignment measurement).
- On a Sensor Controller side, supplementary use operations and branches of the Sensor Controller to configure a check flow such as “data should not be externally provide if the data is in a range from -XXXXX to XXXXX” based on the stage/robots range of movement.

Communication with High-order Device

- After confirming that the product is started up, communicate with the high-order device. Since uncertain signals may be output from the high-order interface at the product start-up, take measures such as clearing the reception buffer of your device at the initial stage.

5-3 Sensor Controller Installation

5-3-1 All Series



Precautions for Safe Use

Power Supply and Wiring

- Make sure to use the product with the power supply voltage specified by this manual.
- Provide the power from a DC power supply (safety extra-low voltage circuits) that has been taken measures not to generate high-voltage.
- Make sure to tighten all screws in mounting.

5-3-2 FH-1000/2000/3000/5000 Series



Precautions for Safe Use

Power Supply and Wiring

- Keep the power supply wires as short as possible (Max. 2 m).
- Use the wire of a suitable size (AWG 10 to 16) according to the current consumption.

Ground

- The power supply circuit of the FH Sensor Controller is insulated from the internal circuit.
- When a base is packed in a camera that will be connected to the Sensor Controller, make sure to mount the camera using the base. Since the enclosure of the camera body is connected to the internal circuits, the circuits may cause short-circuit with FG if the base is not used to mount the camera and result in malfunction or damage.
- Apply Class D grounding (grounding resistance: 100 [Ω] or less)
- Provide the grounding point as close to the product as possible to shorten the grounding wire.
- Wire the grounding wire for the Sensor Controller independently. If the grounding wire is shared with other devices or connected to a building beam, the Sensor Controller may be adversely affected.

Connect the FH-1000/2000/3000/5000 Series to FH-MT12

Do not ground the positive terminal of the 24 VDC power supply when connecting the Sensor Controller and FH-MT12 using a USB cable. The internal circuits may cause a short-circuit and result in malfunction.

Connect the FH-1000/2000/3000/5000 Series to FH-SC12/FH-SM12 (12 megapixels camera)

Do not ground the positive terminal of the 24 VDC power supply when connecting the Sensor Controller and a 12 megapixels camera like FH-SC12 or FH-SM12.



Precautions for Correct Use

When connecting the sensor controller and monitor with a switcher and splitter

Do not use devices that may require re-recognition of the monitor by the Sensor Controller when a switching operation was performed. If such re-recognition processing happens at switching operation, it may cause measurement time to be longer.

Connection of Terminal Block of FH-1000/2000/3000/5000 Series

Connecting of Sensor Controller's terminal block in order to connect package the terminal block connector (male; FH-XCN).

Use the specified wire size (AWG10 to 16) and keep the power supply wires as short as possible (Max. 2 m).

- 1** Insert the end of the signal line (electric wire) into the terminal block connector (male), and tighten the three screws on the connector top to fix the wire. Recommended tightening torque: 0.7-0.8 N•m
- 2** Connect the wire and power source to the terminal block connector (male) depending on the indicated terminal block connector.

Indicate of terminal block connector	Function
+	Connect the DC output positive (+V) of 24 VDC power.
-	Connect the DC output positive (-V) of 24 VDC power.
	Connect the earth.

- 3** Insert the terminal block connector (male) to the terminal block connector (female) of Sensor Controller.
- 4** Tightens and fix the left and right screws for the terminal block connector (male). (Recommended tightening torque: 0.7 to 0.8 N•m)

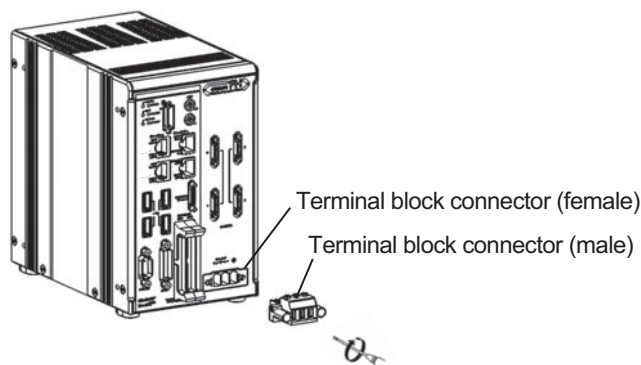

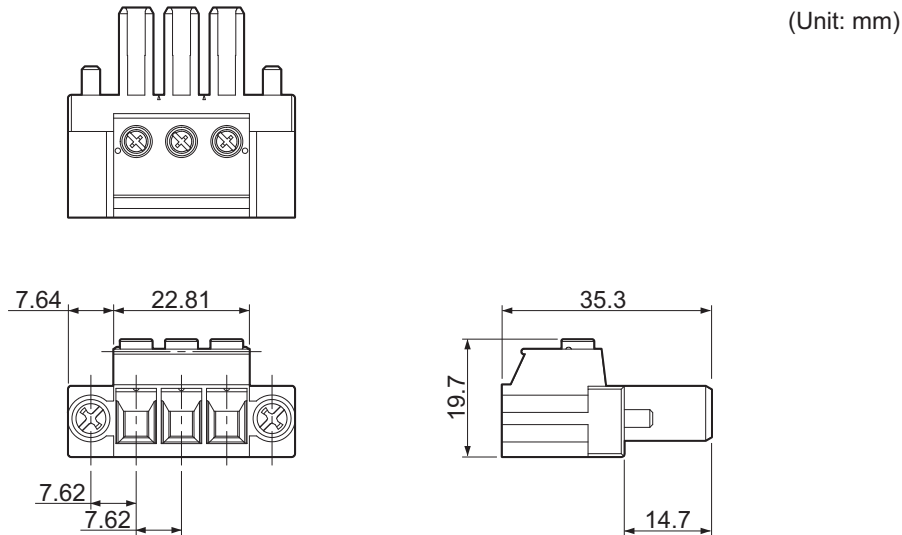

Recommended Power Source of FH-1000/2000/3000/5000 Series

Power source types for FH series differ depending on the number of cameras due to current consumption differences. Refer to the following table to use the appropriate type.

When you connect your camera to the lighting via Light Controller, the current consumption is same as when the Intelligent Compact Digital camera is connected.

Item	Connected camera, Lighting controller, and Lighting type	FH-3050	FH-3050-10	FH-3050-20
Recommended Power Source S8VK-G S8VS	<ul style="list-style-type: none"> When connecting intelligent compact digital cameras: When connecting the following lightings or light controllers without external power supplies: <ul style="list-style-type: none"> FLV-TCC1 FLV-TCC4 FLV-TCC3HB FLV-TCC1EP FL-TCC1 When connecting the following lighting or light controllers: <ul style="list-style-type: none"> FL-TCC1PS FL-MD□MC 	S8VK-G12024 S8VS-12024	S8VK-G24024 S8VS-18024	S8VK-G48024 S8VS-48024
	Other than above case	S8VK-G12024 S8VS-12024	S8VK-G24024 S8VS-18024	S8VK-G24024 S8VS-18024

Item	Connected camera, Lighting controller, and Lighting type	FH-1050	FH-1050-10	FH-1050-20
Recommended Power Source S8VK-G S8VS	<ul style="list-style-type: none"> When connecting intelligent compact digital cameras: When connecting the following lightings or light controllers without external power supplies: <ul style="list-style-type: none"> FLV-TCC1 FLV-TCC4 FLV-TCC3HB FLV-TCC1EP FL-TCC1 When connecting the following lighting or light controllers: <ul style="list-style-type: none"> FL-TCC1PS FL-MD□MC 	S8VK-G12024 S8VS-12024	S8VK-G24024 S8VS-18024	S8VK-G48024 S8VS-48024
	Other than above case	S8VK-G12024 S8VS-09024	S8VK-G12024 S8VS-12024	S8VK-G24024 S8VS-18024

Item	Connected camera, Lighting controller, and Lighting type	FH-5050	FH-5050-10	FH-5050-20
Recommended Power Source S8VK-G S8VS	<ul style="list-style-type: none"> When connecting intelligent compact digital cameras: When connecting the following lightings or light controllers without external power supplies: <ul style="list-style-type: none"> FLV-TCC1 FLV-TCC4 FLV-TCC3HB FLV-TCC1EP FL-TCC1 When connecting the following lighting or light controllers: <ul style="list-style-type: none"> FL-TCC1PS FL-MD□MC 	S8VK-G24024 S8VS-18024	S8VK-G24024 S8VS-24024	S8VK-G48024 S8VS-48024
	Other than above case	S8VK-G12024 S8VS-12024	S8VK-G24024 S8VS-18024	S8VK-G24024 S8VS-18024

Item	Connected camera, Lighting controller, and Lighting type	FH-2050	FH-2050-10	FH-2050-20
Recommended Power Source S8VK-G S8VS	<ul style="list-style-type: none"> When connecting intelligent compact digital cameras: When connecting the following lightings or light controllers without external power supplies: <ul style="list-style-type: none"> FLV-TCC1 FLV-TCC4 FLV-TCC3HB FLV-TCC1EP FL-TCC1 When connecting the following lighting or light controllers: <ul style="list-style-type: none"> FL-TCC1PS FL-MD□MC 	S8VK-G12024 S8VS-12024	S8VK-G24024 S8VS-18024	S8VK-G48024 S8VS-48024
	Other than above case	S8VK-G12024 S8VS-09024	S8VK-G12024 S8VS-12024	S8VK-G24024 S8VS-18024

Mounting of FH-1000/2000/3000/5000 Series

- Make sure to tighten all screws in mounting.
- For good ventilation, provide a clearance of 50 [mm] or more above the Sensor Controller away from other devices in the normal floor mounting. For the right and left sides, provide a clearance of 30 [mm] or more, and for the back side, 15 [mm] or more. These clearances are also required when mounting multiple Sensor Controllers side by side. For the back mounting, the back-side clearance of 15 [mm] is not required.
- Do not install the product immediately above significant heat sources, such as heaters, transformers, or large-capacity resistors.
- Do not install the Sensor Controller in a cabinet with high-voltage equipment installed.
- Mount the Sensor Controller at 200 [mm] or more from power cables apart.

● Side Mounting

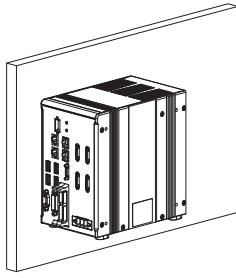

• Left side

4-M4 depth 4.5 (mounting screw hole)

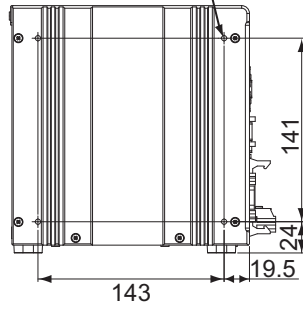

(Unit: mm)

• Right side

4-M4 depth 4.5 (mounting screw hole)

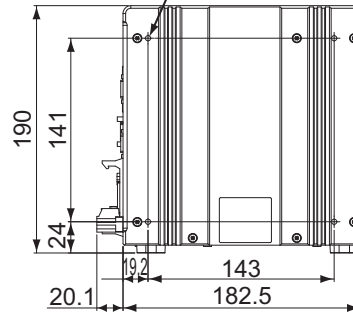

- * Recommended tightening torque: 1.2 N•m to 1.3 N•m
- * The tolerance is ± 0.2 mm.

● Bottom Mounting

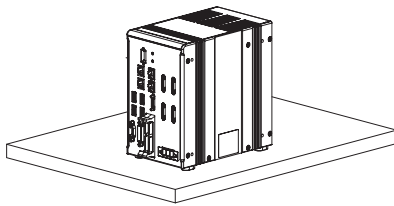

• Bottom

4-M3 depth 4.5 (mounting screw hole)

Insulating leg: 4

(Unit: mm)

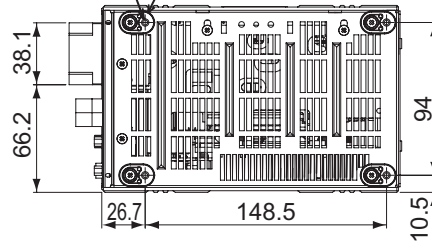

- * Do not remove the Insulating leg. Fix the Insulating leg to secure the ventilation path.
- * Recommended tightening torque: 0.54 N•m to 0.6 N•m
- * The tolerance is ± 0.2 mm.

5-3-3 FH-L Series



Precautions for Safe Use

Power Supply and Wiring

- Keep the power supply wires as short as possible (Max. 2 m).
- Use the wire of a suitable size (AWG 10 to 16) according to the current consumption.
- Recommended power source for FH-L series: OMRON S8VK-G□□□24 or S8VS-□□□24.

Ground

- The power supply circuit of the Sensor Controller is not insulated from the internal circuit.
- When a base is packed in a camera that will be connected to the Sensor Controller, make sure to mount the camera using the base. Since the enclosure of the camera main body made of metals is short-circuited with the internal circuit, the internal circuit might be short-circuited with FG if no base is used, so that failures or malfunctions may be caused.
- Apply Class D grounding (grounding resistance: 100 [Ω] or less)
- Provide the grounding point as close to the product as possible to shorten the grounding wire.
- Wire the grounding wire for the Sensor Controller independently. If the grounding wire is shared with other devices or connected to a building beam, the Sensor Controller may be adversely affected.

Connect the FH-L series Sensor Controller to the FH-MT12 Touch panel monitor.

Do not ground the positive terminal of the 24 VDC power supply when connecting the Sensor Controller and FH-MT12 using a USB cable. The internal circuits may cause a short-circuit and result in malfunction.

When connect the FH-L series Sensor Controller to the FH-SC12/FH-SM12: 12 megapixels camera

Do not ground the positive terminal of the 24 VDC power supply when connecting the Sensor Controller and a 12 megapixels camera like FH-SC12 or FH-SM12.

Connection of Terminal Block of FH-L Series

Connect to the terminal block by using the terminal connector, male: FH-XCN-L, which is packaged with Sensor Controller.

Use the wire of a suitable size (AWG 12 to 16) according to the current consumption. Keep the power supply wires as short as possible: Max. 2m.

- 1 Insert the end of the signal line, electric wire, into the terminal block connector (male). Tighten the three screws on the connector top to secure the wire. Recommended tightening torque: 0.5 to 0.6 N•m
- 2 Insert the terminal block connector (male) into the terminal block connector (female) on the FH Sensor Controller side.

Power Terminal Connector	Function
+	Connect to the DC output terminal +V of 24 VDC.
-	Connect to the DC output terminal -V of 24 VDC.
	Connect to the earth.

- 3 Insert the power supply terminal connector (male) into the power supply terminal connector (female) on the sensor controller side.
- 4 Secure the terminal block connector (male) by tightening the screws on the right and left sides of it with a flathead screwdriver. Recommended tightening torque: 0.5 to 0.6 N•m

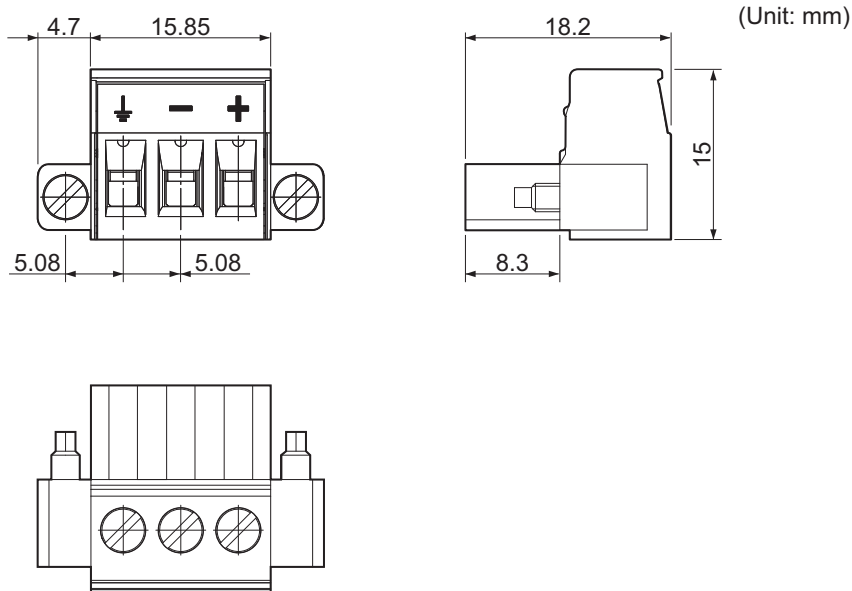
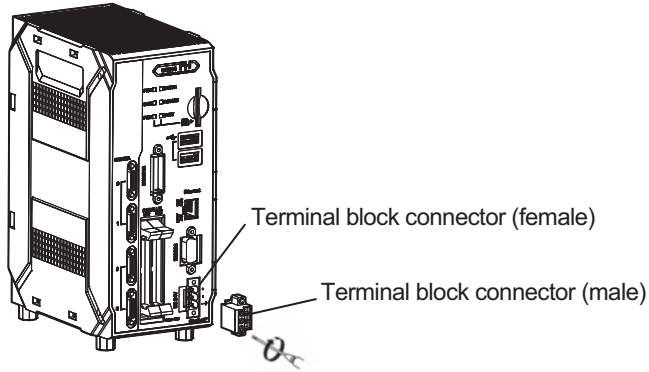

Recommended Power Source for FH-L Series

The power source connected to the FH-L series Sensor Controller changes the power consumption depending on the number of camera. Refer to the following table.

When you connect the camera using lighting Controller, the power consumption is same when connect to the Intelligent Compact Digital Camera.

Item	Camera type	No. of camera	FH-L□□□	FH-L□□□-□□
Recommended Power Source S8VK-G S8VS	Intelligent Compact Digital Camera	2	S8VK-G12024 S8VS-09024	S8VK-G12024 S8VS-09024
		4	-	S8VK-G12024 S8VS-12024
	Camera of 0.3/2/4/5/12 million pixels	2	S8VK-G06024 S8VS-06024	S8VK-G06024 S8VS-06024
		4	-	S8VK-G06024 S8VS-06024

Mounting of FH-L Series

- Make sure to tighten all screws in mounting.
- For good ventilation, provide a clearance of 50 [mm] or more above the Sensor Controller away from other devices in the normal floor mounting. For the right and left sides, provide a clearance of 30 [mm] or more, and for the back side, 15 [mm] or more. These clearances are also required when mounting multiple Sensor Controllers side by side. For the back mounting, the back-side clearance of 15 [mm] is not required.
- Do not install the product immediately above significant heat sources, such as heaters, transformers, or large-capacity resistors.
- Do not install the Sensor Controller in a cabinet with high-voltage equipment installed.
- Mount the Sensor Controller at 200 [mm] or more from power cables apart.

● Mounting the base of the Sensor Controller (Floor mounting)

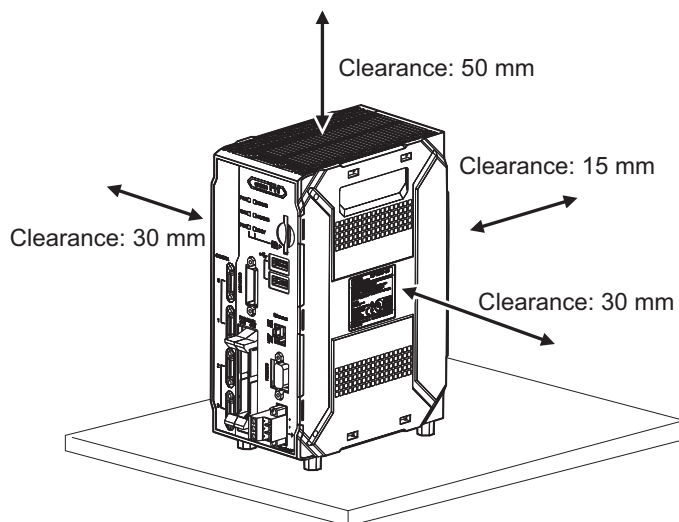

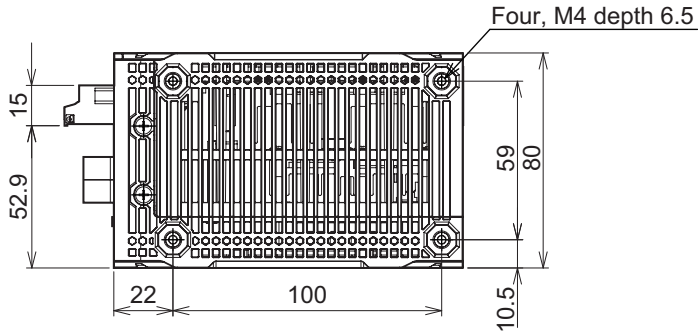

- Recommended tightening torque: 0.54 to 0.6 N•m
- The tolerance: ± 0.2 mm

● **Mounting of the Back Side**

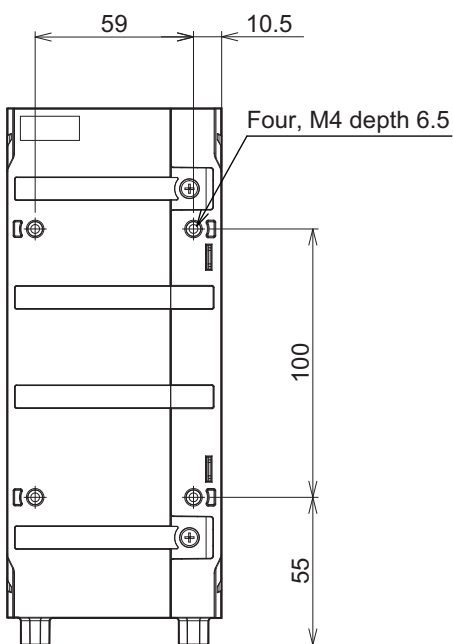
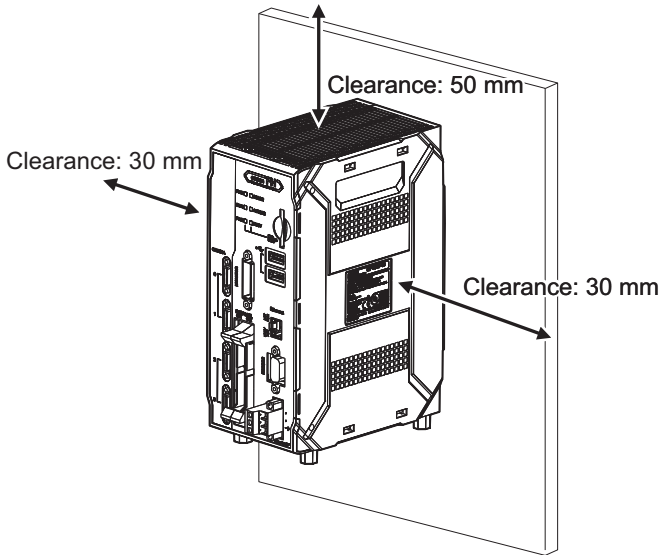

- Recommended tightening torque: 0.54 to 0.6 N•m

- The tolerance: ± 0.2 mm

● Mounting the DIN rail

Mount DIN rail mounting bracket: FH-XDM-L, to the four mount holes on the back of the Sensor Controller.

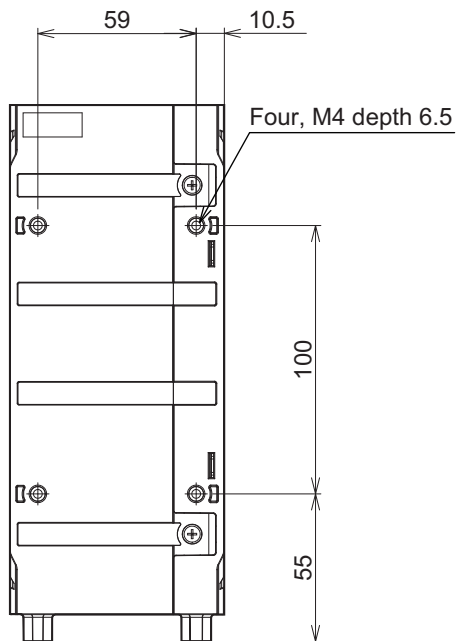
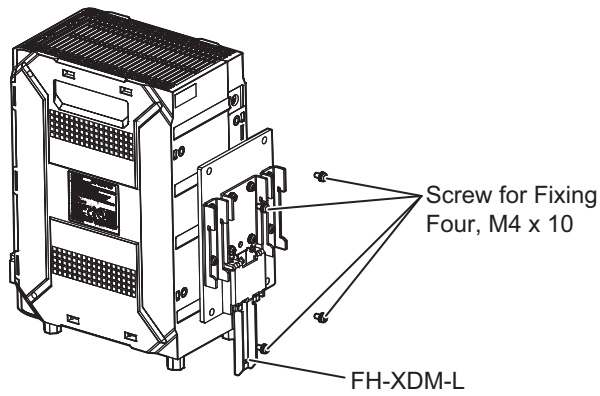

- Recommended tightening torque: 0.54 to 0.6 N•m
- The tolerance: ± 0.2 mm

- Dimensions of DIN rail mounting bracket: FH-XDM-L

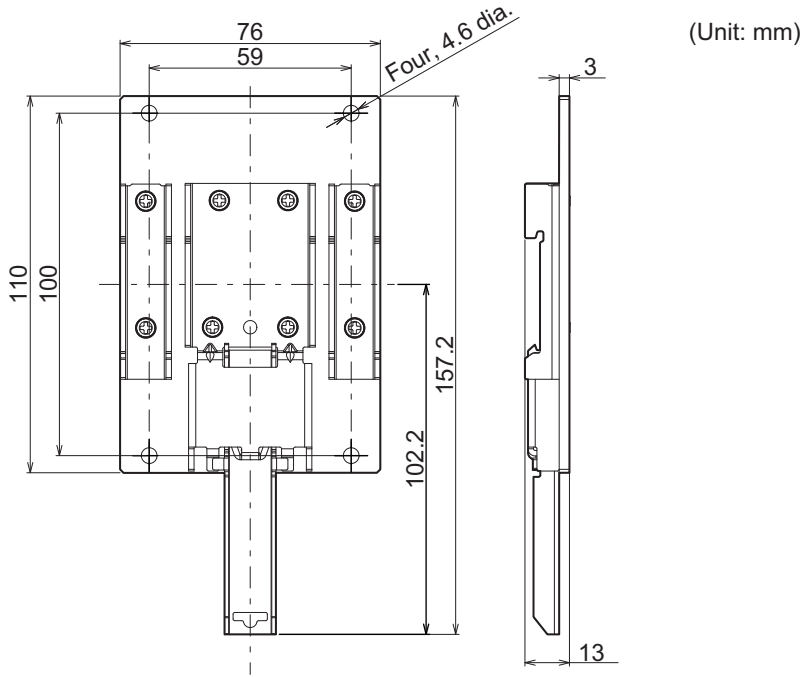

- When mounting the DIN rail, for improvement of heat dissipation, install the product in the following orientation only.

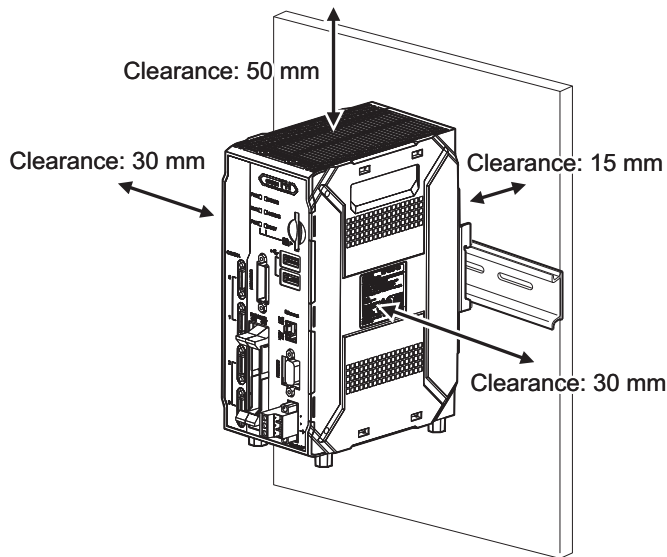

- Do not install in this orientation.

Set DIN rail to the bottom of the Sensor Controller.

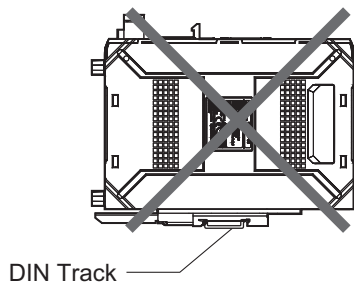

Set DIN rail on the top of the Sensor Controller.

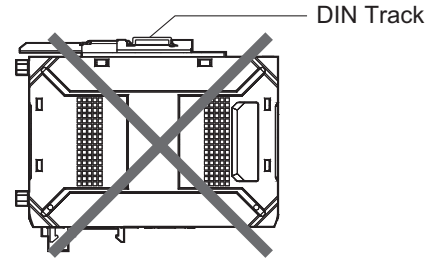

Set DIN rail vertically to the Sensor Controller.

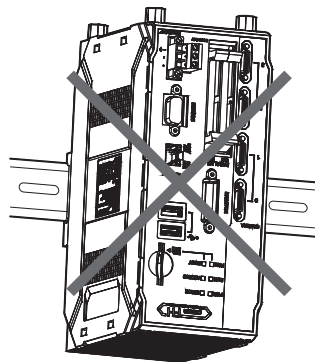

Set DIN rail horizontally to the Sensor Controller.

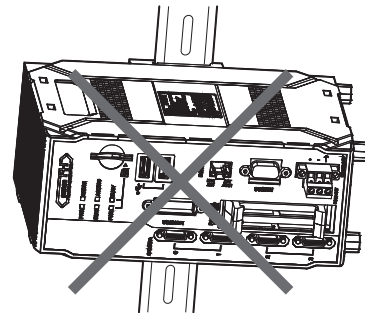

- When mounting the Sensor Controller to the DIN rail, click the rail stoppers, hook the part of A to rail one to the end, and then push up the rail stoppers with pushing to B direction.

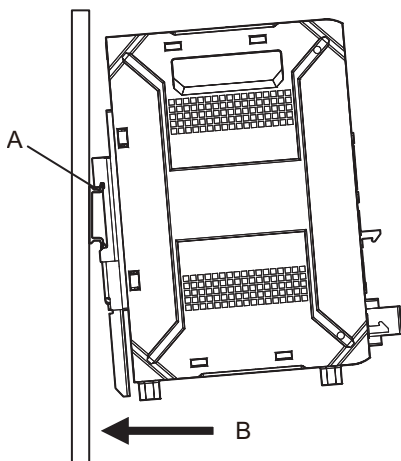

- When removing, insert a flat-head screwdriver to the part of C and pull off.

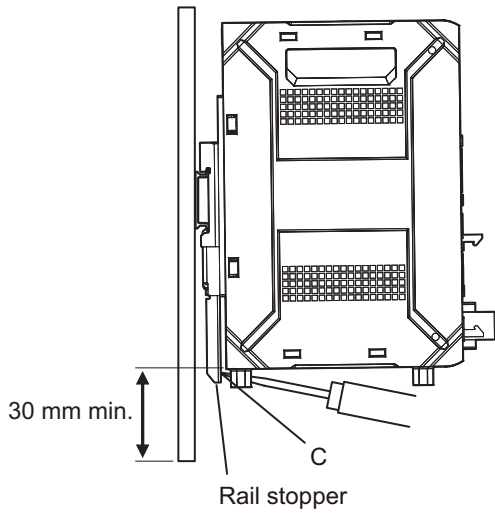

- The back clearance of DIN rail when mount the DIN rail is 16.1 mm.

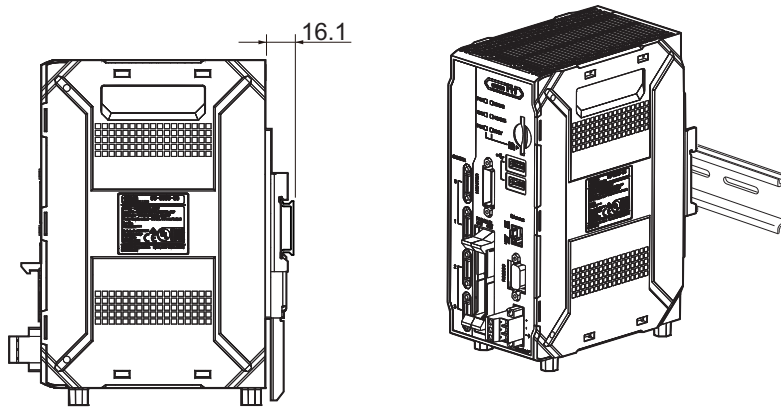

- The following items are recommended for mounting DIN rail.

Name	Model	Manufacturer	Note
DIN35 mm rail	NS 35/ 7,5 PERF	PHOENIX CON-TACT	<ul style="list-style-type: none"> • Length: 75.5/95.5/115.5/200 cm • Material: Iron • Surface: Conductive
	NS 35/ 15 PERF		
End plate	CLIPFIX 35		Need 2 pieces each Sensor Controller.

- DIN rail Dimensions:
NS 35/7.5 PERF

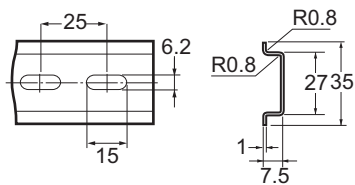

NS 35/165 PERF

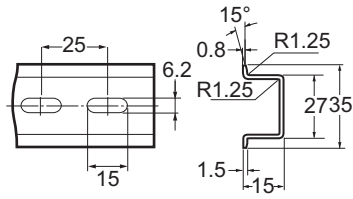

- End plate

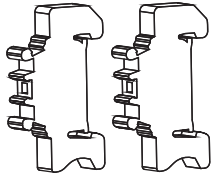

For screw or washer, refer to the followings.

Model	Screw Diameter	(a)
NS 35/ 7,5 PERF	M6	4.6 mm max.
NS 35/ 15 PERF		10 mm max.

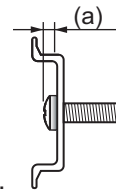

(a): Length between head of screw and fastening surface.

5-4 Setup Touch Panel Monitor or Monitor

Describes the notifications of Sensor Controller when you setup Touch Panel Monitor or Monitor. For handling or functions of monitor, refer to each of instruction sheet.

5-4-1 All Series



Precautions for Safe Use

- Use specialized cameras and cables for the product. If not, it may cause malfunction or damage.
- Make sure to turn off the power when attach or detach cameras or cables. Connecting cables while the power is supplied may cause malfunction or damage to cameras or peripheral devices.
- Do not apply torsion stress to cables. If not, it may cause damage to cables.
- Secure the minimum bending radius of cables. If not, it may cause damage to cables.

5-4-2 FH-1000/2000/3000/5000 Series



Precautions for Safe Use

- DVI-I connector: Please insert the connector perpendicularly so that the connector resin part and pin are not rubbing against each other. Damaged pin may cause contact failure due to generation and invasion of resin powder.
- Do not ground the positive terminal of the 24 VDC power supply when connecting the Sensor Controller and FH-MT12 using a USB cable. The internal circuits may cause a short-circuit and result in malfunction.



Precautions for Correct Use

When connecting the sensor controller and monitor with a switcher and splitter

Do not use devices that may require re-recognition of the monitor by the Sensor Controller when a switching operation was performed. If such re-recognition processing happens at switching operation, it may cause measurement time to be longer.

When fix the DVI connector

If difficult to fix the bilateral screws of DVI connector, once loosen these. Then retry to fix, again.

5-4-3 FH-L Series



Precautions for Safe Use

- Monitor connector: Please insert the connector perpendicularly so that the connector resin part and pin are not rubbing against each other. Damaged pin may cause contact failure due to generation and invasion of resin powder.
- Do not ground the positive terminal of the 24 VDC power supply when connecting the Sensor Controller and FH-MT12 using a USB cable. The internal circuits may cause a short-circuit and result in malfunction.



Precautions for Correct Use

When connecting the sensor controller and monitor with a switcher and splitter

Do not use devices that may require re-recognition of the monitor by the Sensor Controller when a switching operation was performed. If such re-recognition processing happens at switching operation, it may cause measurement time to be longer.

When fix the DVI connector

If difficult to fix the bilateral screws of DVI connector, once loosen these. Then retry to fix, again.

5-5 Camera Installation

Guidelines and precautions for Sensor Controller installation when cameras are also installed. For handling and function information for specific cameras, refer to the appropriate instruction sheet.

5-5-1 All Series

WARNING

If you keep watching the LED light, it may have an adverse effect on the eyes, do not stare directly into the light emitted from the LED. If a specular object is used, take care not to allow reflected light to enter your eyes.



Caution

Please take fail-safe measures on your side in preparation for an abnormal signal due to signal conductor disconnection and/or momentary power interruption. An abnormal operation may result in a serious accident.



Precautions for Safe Use

- Use specialized cameras and cables for the product. If not, it may cause malfunction or damage.
- Make sure to turn off the power when attach or detach cameras or cables. Connecting cables while the power is supplied may cause malfunction or damage to cameras or peripheral devices.
- Since cables to which bending is frequently applied is easily broken, use the robotic cable type (bending resistant cable) to prevent damages.
- Do not apply torsion stress to cables. If not, it may cause damage to cables.
- Secure the minimum bending radius of cables. If not, it may cause damage to cables.
- While the power is ON or immediately after the power is turned OFF, the Sensor Controller and camera case are still hot. Do not touch the case.



Precautions for Correct Use

Maintenance

- Turn OFF the power and ensure the safety before maintenance.
- Clean the lens with a lens-cleaning cloth or air brush.
- Lightly wipe off dirt with a soft cloth.
- Dirt on the image element must be removed using an air brush.
- Do not use thinners or benzine.
- When installing / replacing the camera, reset the parameter settings of the corresponding Camera Image Input processing item.

5-5-2 FH-1000/2000/3000/5000 Series



Precautions for Safe Use

- **Ground**

When a base is packed in a camera that will be connected to the Sensor Controller, make sure to mount the camera using the base. Since the enclosure of the camera body is connected to the internal circuits, the circuits may cause short-circuit with FG if the base is not used to mount the camera and result in malfunction or damage.

- **Connect the FH-1000/2000/3000/5000 Series to FH-SC12/FH-SM12 (12 megapixels camera)**

Do not ground the positive terminal of the 24 VDC power supply when connecting the Sensor Controller and a 12 megapixels camera like FH-SC12 or FH-SM12.

Mounting of Ferrite core

Mount the ferrite core attached to the camera cable to near the Sensor Controller.

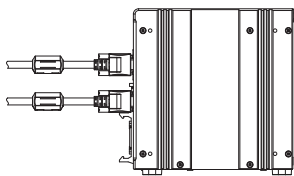

Camera cable mounting

Connect the cable with securing the connector length and the minimum bending radius to the Sensor Controller.

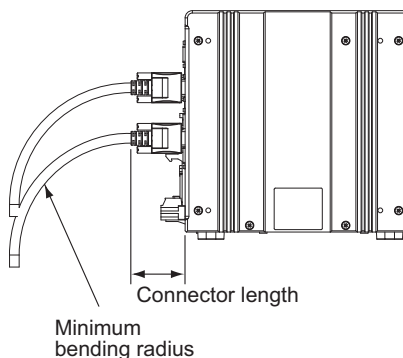

Name	Model	Minimum bending radius	Connector length
Camera Cable	FZ-VS3	69 [mm]	30 [mm]
Right-angle Camera Cable	FZ-VSL3		
Bend resistant Camera Cable	FZ-VSB3		
Bend resistant Right-angle Camera Cable	FZ-VSLB3		
Long-distance Camera Cable	FZ-VS4	78 [mm]	42 [mm]
Long-distance Right-angle Camera Cable	FZ-VSL4		

5-5-3 FH-L Series



Precautions for Safe Use

- **Ground**

When a base is packed in a camera that will be connected to the Sensor Controller, make sure to mount the camera using the base. Since the enclosure of the camera main body made of metals is short-circuited with the internal circuit, the internal circuit might be short-circuited with FG if no base is used, so that failures or malfunctions may be caused.

-

- **When connect the FH-L series Sensor Controller to the FH-SC12/FH-SM12: 12 megapixels camera**

Do not ground the positive terminal of the 24 VDC power supply when connecting the Sensor Controller and a 12 megapixels camera like FH-SC12 or FH-SM12.

Camera cable mounting

Connect the cable with securing the connector length and the minimum bending radius to the Sensor Controller.

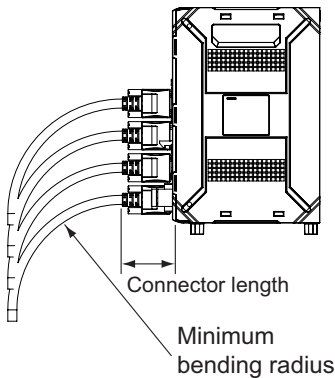

Name	Model	Minimum bending radius	Connector length
Camera Cable	FZ-VS3	69 [mm]	30 [mm]
Right-angle Camera Cable	FZ-VSL3		
Bend resistant Camera Cable	FZ-VSB3		
Bend resistant Right-angle Camera Cable	FZ-VSLB3		
Long-distance Camera Cable	FZ-VS4	78 [mm]	42 [mm]
Long-distance Right-angle Camera Cable	FZ-VSL4		

5-6 Insert/Remove SD Memory Card or USB memory

5-6-1 Common in all series



Precautions for Correct Use

When removing USB memory

- Before removing a USB memory device, make sure that data is not being read or written to them.
- For a USB memory device, the memory device's LED flashes or lights while data is being read or written, so make sure that it is turned OFF before removing the memory.
- When a message is displayed indicating that a task is in progress, do not turn OFF the power. Doing so causes the data in the memory to be corrupted, resulting in the product not operating properly upon the next start-up.

Do not insert or remove USB memory during measurement, loading, and writing. There is the possibility of measurement time or damage of data.



Precautions for Correct Use

Handling of SD memory card

- When you touch a terminal part of SD memory card, antistatic is required by using a wrist strap or others.
- Do not insert an SD memory card in the reverse orientation, at an angle, or in a twisting manner.

Removing SD memory card

- Before removing a SD memory card, make sure that data is not being read or written to them.
- For SD memory card, the SD BUSY LED flashes or lights while data is being read or written, so make sure that it is turned OFF before removing the memory.
- When a message is displayed indicating that a task is in progress, do not turn OFF the power. Doing so causes the data in the memory to be corrupted, resulting in the product not operating properly upon the next start-up.

Do not insert or remove SD memory card during measurement, loading, and writing. There is the possibility of measurement time or damage of data.



Additional Information

For external storage device and external drive name, refer to the *Using External Storage Devices and External Drive Name* in the Vision System FH/FHV Series User's Manual (Cat. No. Z365).

5-7 Use by Connecting Software

Sysmac Studio FH tool, FZ_FH Remote Operation tool, and Simulation Software are dedicated software.

5-7-1 Sysmac Studio FH Tool

Sysmac Studio FH tool is supported only FH-1000/2000/3000/5000 series.
When you purchase these series newly, both software DVD and icons are required.



Additional Information

For Sysmac Studio FH tool, refer to the *Vision System FH Series Operation Manual for Sysmac Studio (Cat. No. Z343)*.

5-7-2 FZ_FH Remote Operation Tool

FZ_FH Remote Operation tool is supported all of the series; FH-1000/2000/3000/5000, and FH-L series.

When you purchase these series newly, both software CD-ROM and license are required.



Additional Information

For details of FZ_FH Remote Operation tool, refer to *Remotely Operating the Controller (Remote Operation)* section in the *Vision System FH/FHV series User's Manual (Cat. No. Z365)*.

5-7-3 Simulation Software

Using the Simulation Software, you can check the operation or functions of Vision System FH series on a PC.

When you purchase these series newly, both software CD-ROM and license are required.



Additional Information

For using the Simulation Software, refer to the description of *How To Use Simulation Software*.

5-8 Installation in a Control Panel

When the Sensor Controller is being installed in a cabinet or control panel, be sure to provide proper ambient conditions as well as access for operation and maintenance.

5-8-1 All Series



Precautions for Safe Use

Installation Environment

- Do not use the product in the environment with flammable or explosive gases.
- Install the product so that the air can flow freely through its cooling vents.
- Regularly clean the vent holes or fan outlet to prevent dust or particles blocking them. Internal temperature increases when those are blocked, it causes malfunction.
- To secure safety for operation and maintenance, install the product apart from high-voltage devices and power devices.
- Make sure to tighten all screws in mounting.

Accessibility for Operation and Maintenance

- Do not apply torsion stress to cables. If not, it may cause damage to cables.
- Secure the minimum bending radius of cables. If not, it may cause damage to cables.



Precautions for Correct Use

Installation and Storage Sites

Install and store the product in a location that meets the following conditions:

- No rapid changes in temperature (place where dew does not form)
- No presence of corrosive or flammable gases
- Place free of dust, salts and iron particles
- Place free of vibration and shock
- Place out of direct sunlight
- Place where it will not come into contact with water, oils or chemicals
- Place not affected by strong electro-magnetic waves
- Place not near to high-voltage, or high-power equipment

Ambient Temperature

- Do not install the product immediately above significant heat sources, such as heaters, transformers, or large-capacity resistors.

Noise Resistance

- Do not install the Sensor Controller in a cabinet with high-voltage equipment installed.
- Mount the Sensor Controller at 200 [mm] or more from power cables apart.

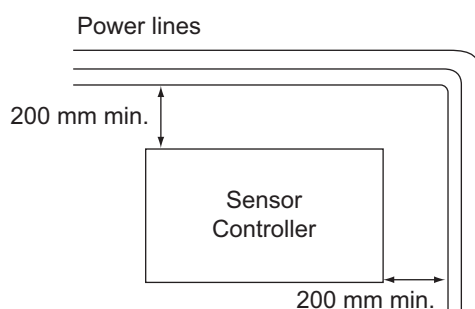

Ambient temperature and humidity

- Panels have been reduced in size due to space-saving and miniaturization in devices and systems, and the temperature inside the panel may be at least 10 to 15°C higher than outside the panel. Implement the following measures against overheating at the installation site and in the panel, and allow a sufficient margin for the temperature.
- The Controller may not start normally if the temperature is below 0°C when the power is turned ON. Maintain an air temperature of at least approximately 5°C inside the panel, by implementing measures such as installing a low-capacity space heater in the panel. Alternatively, leave the Controller power ON to keep the Controller warm.
- Rapid temperature changes can cause condensation to occur, resulting in malfunctioning due to short-circuiting. When there is a possibility of this occurring, take measures against condensation, such as leaving the Controller power ON at night or installing a heater in the control panel to keep it warmer.

Vibration and Shock

The Controller is tested for conformity with the sine wave vibration test method (IEC 60068-2-6) and the shock test method (IEC 60068-2-27) of the Environmental Testing for Electrotechnical Products. It is designed so that malfunctioning will not occur within the specifications for vibration and shock. If, however, the Controller is to be used in a location in which it will be directly subjected to regular vibration or shock, then implement the following countermeasures:

- Separate the control panel from the source of the vibration or shock. Or secure the Controller and the panel with rubber padding to prevent vibration.
- Make the building or the floor vibration-resistant.
- To prevent shock when other devices in the panel such as electromagnetic contactors operate, secure either the source of the shock or the Controller with rubber padding.

Accessibility for Operation and Maintenance

- To ensure safe access for operation and maintenance, separate the Controller as much as possible from high-voltage equipment and power machinery.
- Secure the minimum bending radius of the cable. Otherwise the cable may be damaged.
- Consider the physical size of USB memory, or SD memory card as these will be inserted in to the mounted Sensor Controller.

5-8-2 FH-1000/2000/3000/5000 Series



Precautions for Correct Use

Ambient Temperature

- Install and store the product in a location that meets the following conditions:
 - Surrounding temperature of 0 to +50°C*1 (-20 to +65°C in storage)
 - *1. FH-5000 Series: Surrounding temperature of 0 to 45°C
 - Relative humidity of between 35 to 85%
- Do not let the ambient temperature exceed 50°C (122°F).
- Provide a forced-air fan cooling or air conditioning if the ambient temperature is near 50°C (122°F) so that the ambient temperature never exceeds 50°C (122° F).

Orientation of Product

- For good heat dissipation, install the product only in the position shown below so as not to block the ventilation holes. Install the product so that the air can flow freely through its cooling vents.

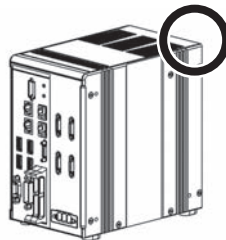

- Do not install the product in the following positions.

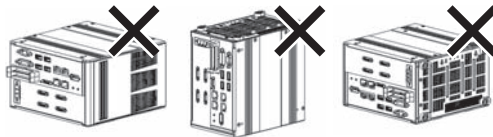

- For good ventilation, provide a clearance of 50 [mm] or more above the Sensor Controller away from other devices in the normal floor mounting. For the right and left sides, provide a clearance of 30 [mm] or more, and for the back side, 15 [mm] or more. These clearances are also required when mounting multiple Sensor Controllers side by side. For the back mounting, the back-side clearance of 15 [mm] is not required.

Accessibility for Operation and Maintenance

Connect the cable with securing the connector length and the minimum bending radius to the Sensor Controller.

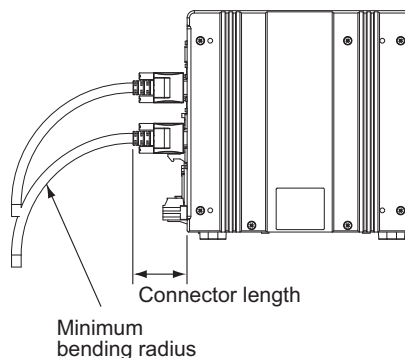

Name	Model	Minimum bending radius	Connector length
Camera Cable	FZ-VS3	69 [mm]	30 [mm]
Right-angle Camera Cable	FZ-VSL3		
Bend resistant Camera Cable	FZ-VSB3		
Bend resistant Right-angle Camera Cable	FZ-VSLB3		
Long-distance Camera Cable	FZ-VS4	78 [mm]	42 [mm]
Long-distance Right-angle Camera Cable	FZ-VSL4		

Installation in a Control Panel

- Make sure to tighten all screws in mounting.
- For good ventilation, provide a clearance of 50 [mm] or more above the Sensor Controller away from other devices in the normal floor mounting. For the right and left sides, provide a clearance of 30 [mm] or more, and for the back side, 15 [mm] or more. These clearances are also required when mounting multiple Sensor Controllers side by side. For the back mounting, the back-side clearance of 15 [mm] is not required.

● Side Mounting

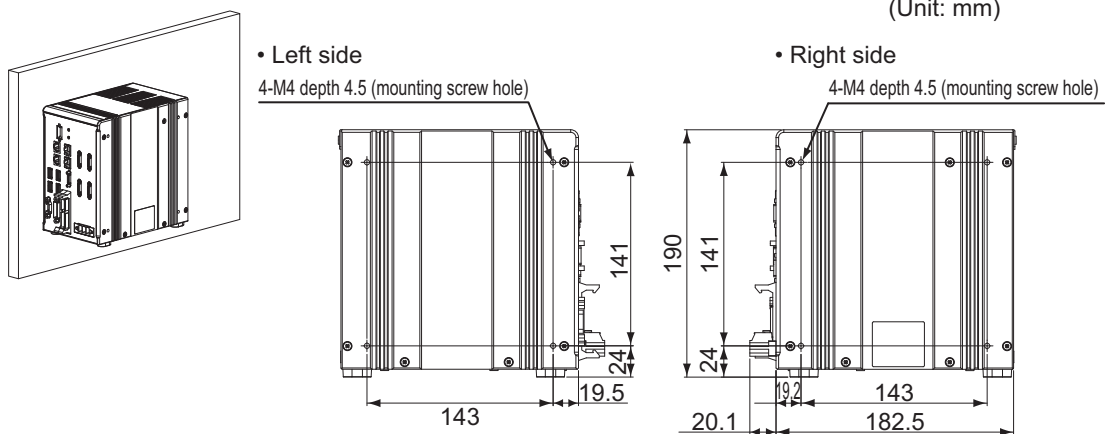

- * Recommended tightening torque: 1.2 N•m to 1.3 N•m
- * The tolerance is ± 0.2 mm.

● Bottom Mounting

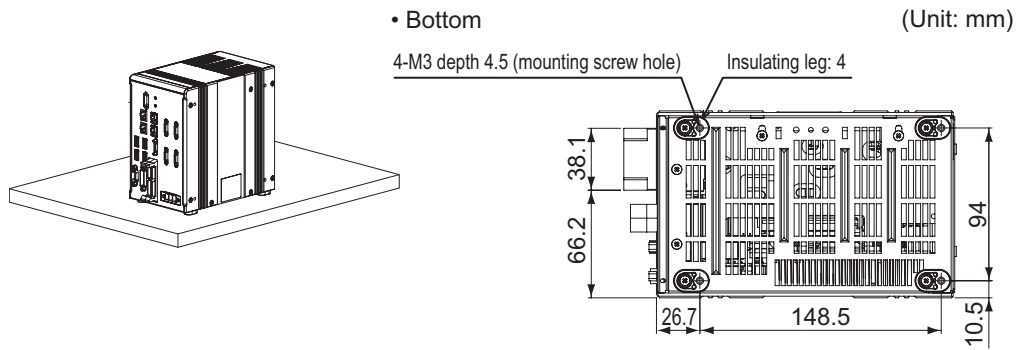

- * Do not remove the Insulating leg. Fix the Insulating leg to secure the ventilation path.
- * Recommended tightening torque: 0.54 N•m to 0.6 N•m
- * The tolerance is ± 0.2 mm.

5-8-3 FH-L Series



Precautions for Correct Use

Ambient Temperature

- Install and store the product in a location that meets the following conditions:
 - Surrounding temperature of 0 to +55°C (-25 to +70°C in storage)
 - Relative humidity of between 10 to 90%
- Do not let the ambient temperature exceed 55°C (131°F).
- Provide a forced-air fan cooling or air conditioning if the ambient temperature is near 55°C (131°F) so that the ambient temperature never exceeds 55°C (131°F).

Orientation of Product

- For good heat dissipation, install the product only in the position shown below so as not to block the ventilation holes.

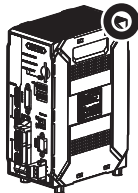

- Do not install the product in the following positions.

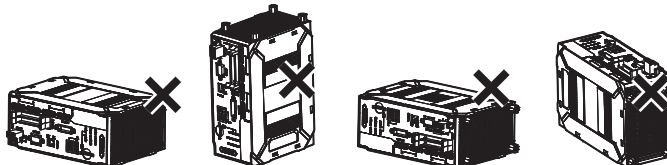

- For good ventilation, provide a clearance of 50 mm or more above the Sensor Controller away from other devices in the normal floor mounting. For the right and left sides, back side, for other devices, or Sensor Controller 25 mm or more.

Accessibility for Operation and Maintenance

Connect the cable with securing the connector length and the minimum bending radius to the Sensor Controller.

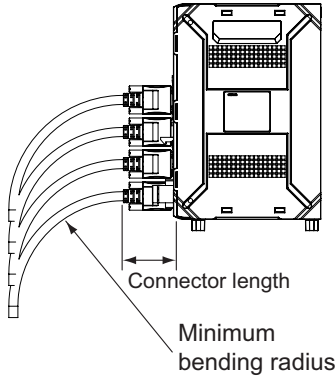

Name	Model	Minimum bending radius	Connector length
Camera Cable	FZ-VS3	69 [mm]	30 [mm]
Right-angle Camera Cable	FZ-VSL3		
Bend resistant Camera Cable	FZ-VSB3		
Bend resistant Right-angle Camera Cable	FZ-VSLB3		
Long-distance Camera Cable	FZ-VS4	78 [mm]	42 [mm]
Long-distance Right-angle Camera Cable	FZ-VSL4		

Installation in a Control Panel

- Make sure to tighten all screws in mounting.
- For good ventilation, provide a clearance of 50 [mm] or more above the Sensor Controller away from other devices in the normal floor mounting. For the right and left sides, provide a clearance of 30 [mm] or more, and for the back side, 15 [mm] or more. These clearances are also required when mounting multiple Sensor Controllers side by side. For the back mounting, the back-side clearance of 15 [mm] is not required.

● Mounting the base of the Sensor Controller (Floor mounting)

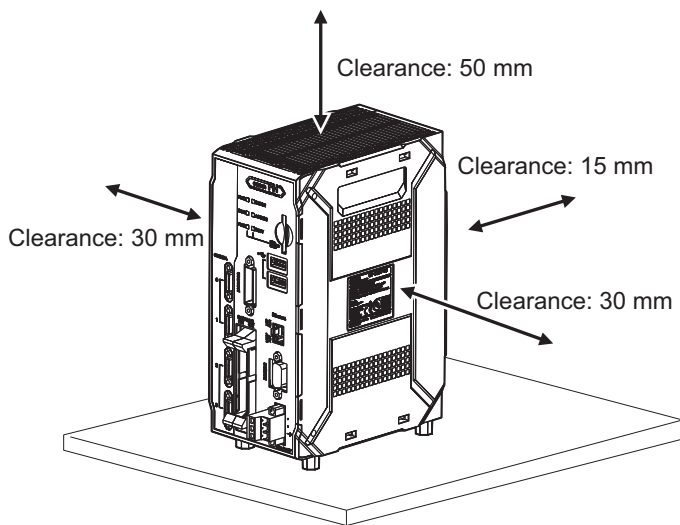

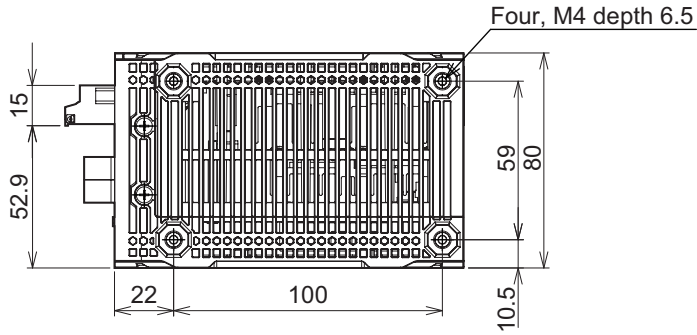

- Recommended tightening torque: 0.54 to 0.6 N•m
- The tolerance: ± 0.2 mm

● **Mounting of the Back Side**

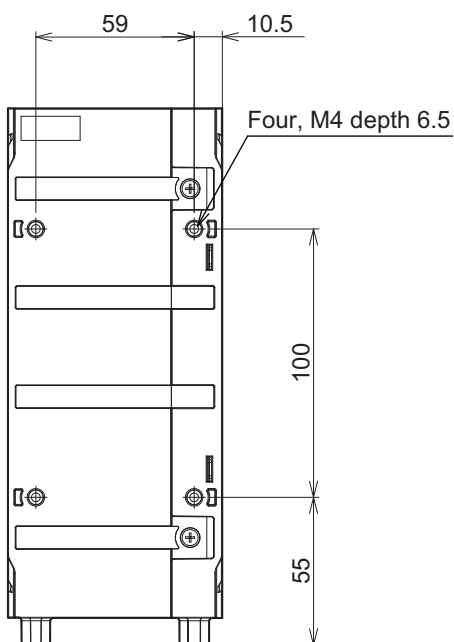
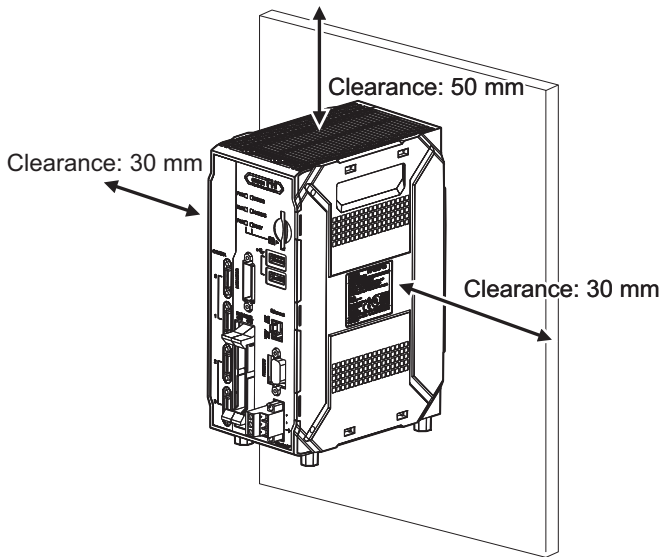

- Recommended tightening torque: 0.54 to 0.6 N•m

- The tolerance: ± 0.2 mm

● Mounting the DIN rail

Mount DIN rail mounting bracket: FH-XDM-L, to the four mount holes on the back of the Sensor Controller.

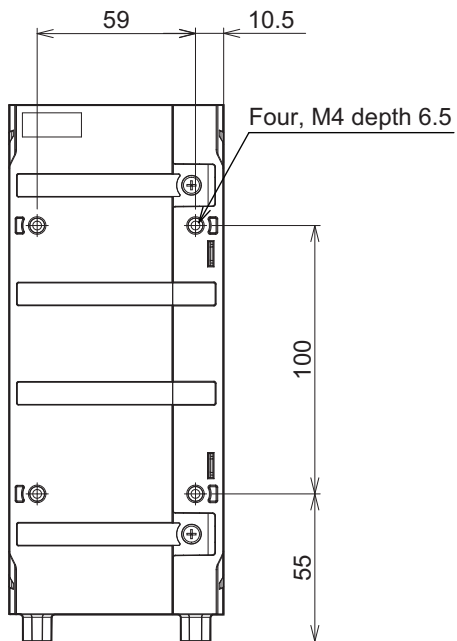
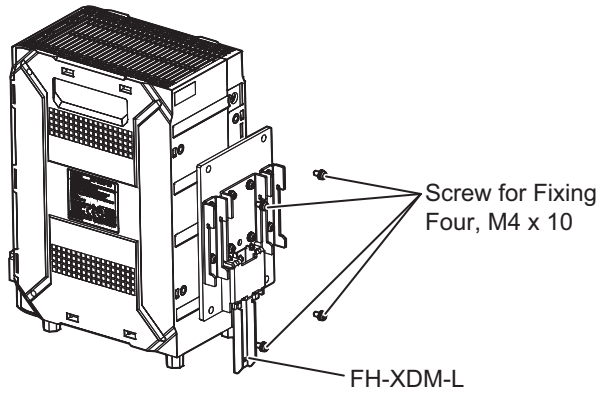

- Recommended tightening torque: 0.54 to 0.6 N·m
- The tolerance: ± 0.2 mm

- Dimensions of DIN rail mounting bracket: FH-XDM-L

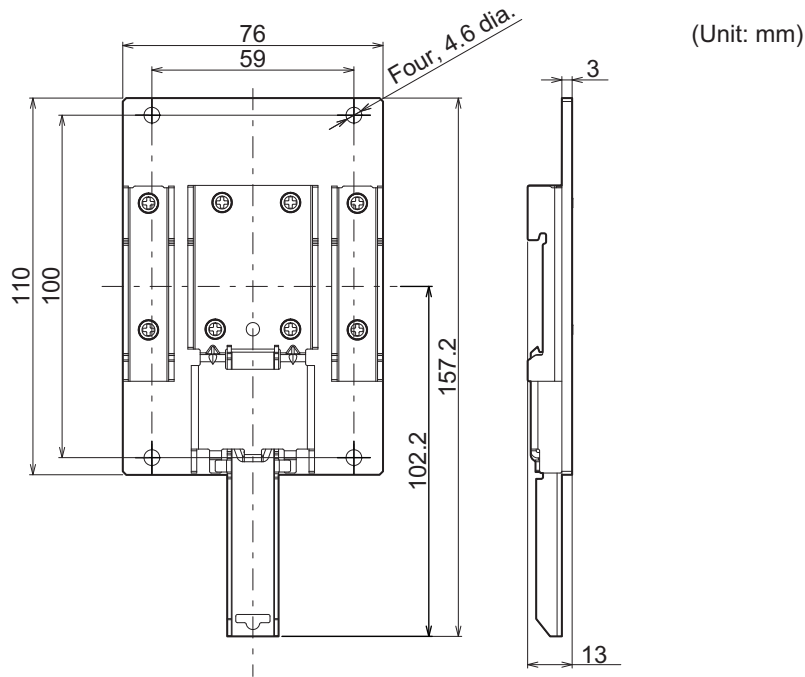

- When mounting the DIN rail, for improvement of heat dissipation, install the product in the following orientation only.

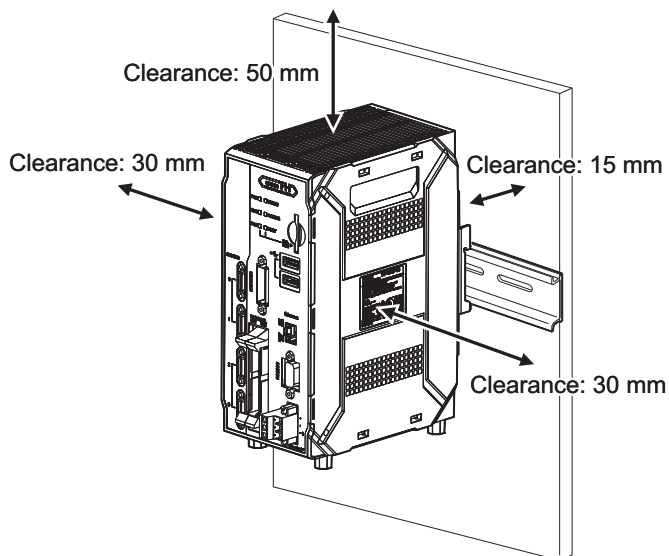

- Do not install in this orientation.

Set DIN rail to the bottom of the Sensor Controller.

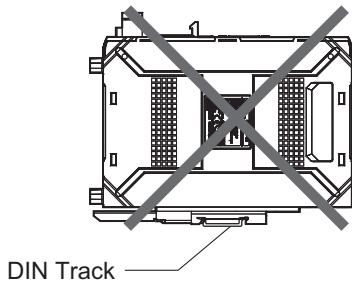

Set DIN rail on the top of the Sensor Controller.

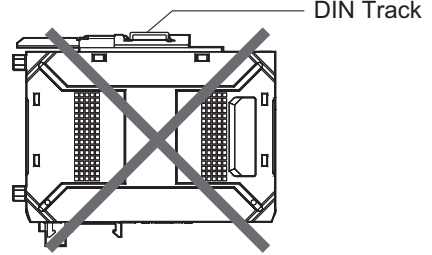

Set DIN rail vertically to the Sensor Controller.

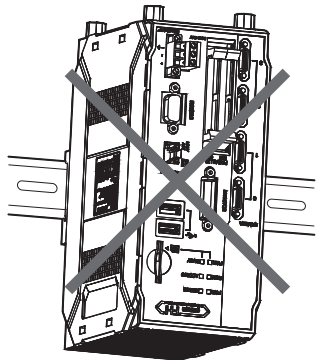

Set DIN rail horizontally to the Sensor Controller.

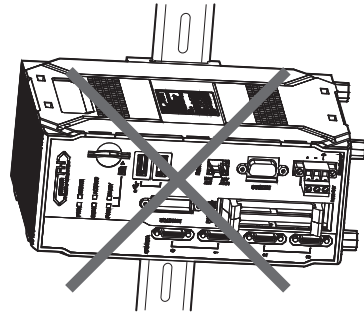

- When mounting the Sensor Controller to the DIN rail, click the rail stoppers, hook the part of A to rail one to the end, and then push up the rail stoppers with pushing to B direction.

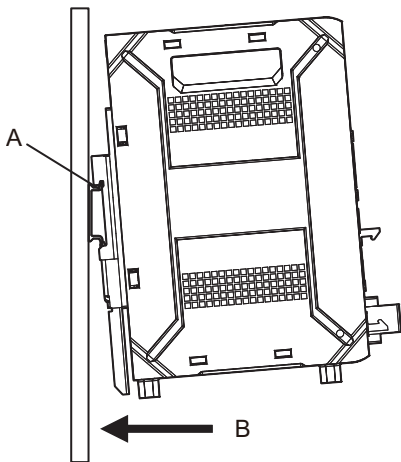

- When removing, insert a flat-head screwdriver to the part of C and pull off.

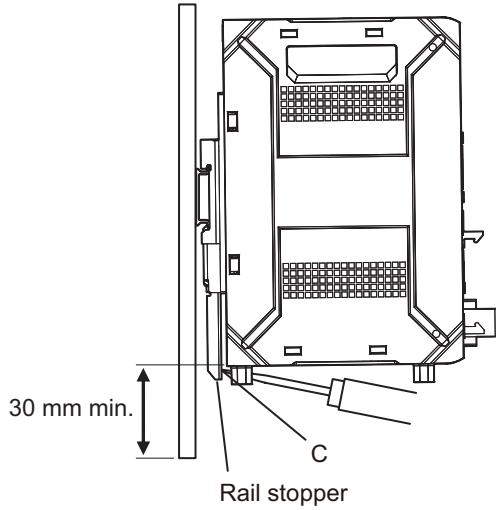

- The back clearance of DIN rail when mount the DIN rail is 16.1 mm.

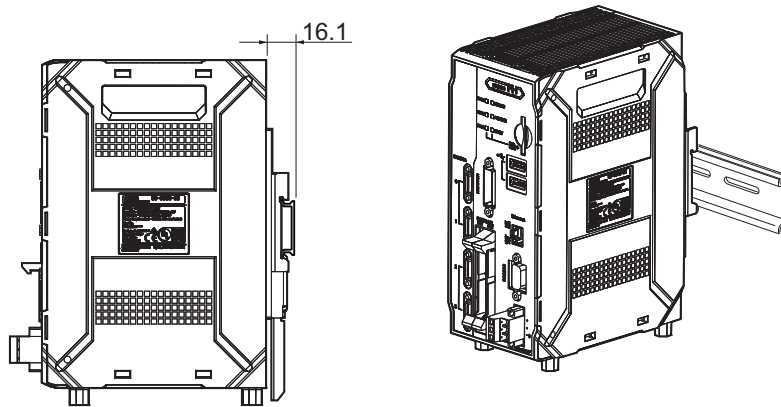

- The following items are recommended for mounting DIN rail.

Name	Model	Manufacturer	Note
DIN35 mm rail	NS 35/ 7,5 PERF	PHOENIX CON-TACT	<ul style="list-style-type: none"> • Length: 75.5/95.5/115.5/200 cm • Material: Iron • Surface: Conductive
	NS 35/ 15 PERF		
End plate	CLIPFIX 35		

- DIN rail Dimensions:
NS 35/7.5 PERF

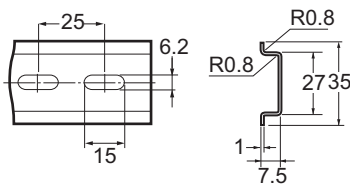

NS 35/165 PERF

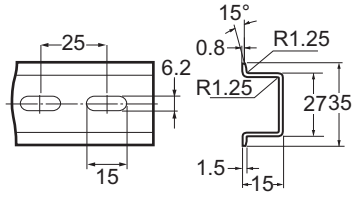

- End plate

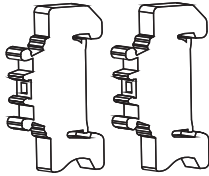

For screw or washer, refer to the followings.

Model	Screw Diameter	(a)
NS 35/ 7,5 PERF	M6	4.6 mm max.
NS 35/ 15 PERF		10 mm max.

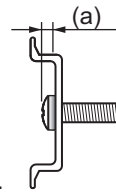

(a): Length between head of screw and fastening surface.

6

I/O Interface

6-1	Parallel Interface	6 - 2
6-1-1	All Series.....	6 - 2
6-1-2	FH-1000/2000/3000/5000 Series.....	6 - 3
6-1-3	FH-L Series.....	6 - 12
6-1-4	Other (Parallel Converter Cable)	6 - 18
6-2	Encoder Interface	6 - 29
6-2-1	FH-1000/2000/3000/5000 Series.....	6 - 29
6-3	EtherCAT Interface	6 - 32
6-3-1	FH-1000/2000/3000/5000 Series.....	6 - 32
6-4	Ethernet Interface	6 - 34
6-4-1	FH-1000/2000/3000/5000 Series.....	6 - 34
6-4-2	FH-L Series.....	6 - 36
6-5	Serial Interface	6 - 38
6-5-1	All Series.....	6 - 38

6-1 Parallel Interface

Parallel interfaces vary by Sensor Controller series. Refer to the appropriate series for information.

6-1-1 All Series



Precautions for Safe Use

- Use only the cables designed specifically for the product. Use of other products may result in malfunction or damage of the product.
 - Always turn OFF the power of the FH-L series Sensor Controller and peripheral devices before connecting or disconnecting a camera or cable. Connecting the cable with power supplied may result in damage of the camera or peripheral devices.
 - Since cables to which bending is frequently applied is easily broken, use the robotic cable type (bending resistant cable) to prevent damages.
 - Do not apply torsion stress to cables. If not, it may cause damage to cables.
 - Secure the minimum bending radius of cables. If not, it may cause damage to cables.
-



Precautions for Correct Use

- Check the following items on the communications cables that are used in the network.
 - Are there any breaks?
 - Are there any shorts?
 - Are there any connector problems?
 - When you connect the cable to the communications connectors on devices, firmly insert the communications cable connector until it locks in place.
 - Do not lay the communications cables together with high-voltage lines.
 - Do not lay the communications cable near devices that generate noise.
 - Do not lay the communications cables in locations subject to high temperatures or high humidity.
 - Do not lay the communications cables in locations subject to excessive dirt and dust or to oil mist or other contaminants.
-

6-1-2 FH-1000/2000/3000/5000 Series

The parallel interface can be used for both NPN and PNP. An appropriate wiring is required according on the external device.

The encoder interface, open collector type, is also included.

The encoder interface, open collector type, is ENCTRIG_A, ENCTRIG_B, ENCTRIG_Z. Connect the corresponding pins to the encoder properly.

Interface Specification

- Specifications vary depending on the pin's role.
- The pins for the encoder interface, open collector type, are ENCTRIG_A (No. 8 and 11), ENCTRIG_B (No. 12 and 13), ENCTRIG_Z (No. 4 and 5). The response frequency of the encoder is 4 [KHz].

● [Input]

Object signals:

- No.14 pin: Use the COMIN1 terminal when using these signals.
- No.37 to 46 pins: Use the COMIN2 terminal when using these signals.

Item	Specifications
Input voltage	12 to 24 VDC $\pm 10\%$
ON current*1	5 mA min.
ON voltage*1	8.8 V min.
OFF current*2	0.5 mA max.
OFF voltage*2	1.1 V max.
ON delay	5 ms max.
OFF delay	0.7 ms max.

*1. ON current and ON voltage:

These are the current value or voltage value to turn ON from OFF. The value for the ON voltage is the potential difference between COMIN and each input terminal.

*2. OFF current and OFF voltage:

These are the current value or voltage value to turn OFF from ON. The value for the OFF voltage is the potential difference between COMIN and each input terminal.

● [Input]

Object signals:

- No.4 to 6, 9 to 11 pins: Use the COMIN1 terminal when using these signals.
- No.7, 8, 12, 13 pins: Use the COMIN0 terminal when using these signals.

Item	Specifications
Input voltage	12 to 24 VDC $\pm 10\%$
ON current*1	5 mA min.
ON voltage*1	8.8 V min.
OFF current*2	0.5 mA max.
OFF voltage*2	0.8 V max.
ON delay	0.1 ms max.

Item	Specifications
OFF delay	0.1 ms max.
Max. response frequency	4 KHz

*1. ON current and ON voltage:

These are the current value or voltage value to turn ON from OFF. The value for the ON voltage is the potential difference between COMIN and each input terminal.

*2. OFF current and OFF voltage:

These are the current value or voltage value to turn OFF from ON. The value for the OFF voltage is the potential difference between COMIN and each input terminal.

● [Output]

Object signals:

- No.15 to 19 pin, No.28 to 32 pin: Use the COMOUT0 terminal when using these signals.
- No.48 to 57 pins: Use the COMOUT2 terminal when using these signals.
- No.58 to 66 pins: Use the COMOUT3 terminal when using these signals.

Item	Specifications
Output voltage	12 to 24 VDC $\pm 10\%$
Load current*1	45 mA max.
ON residual voltage	2 V max.
OFF leakage current	0.2 mA max.

*1. The load current must be the specified current value or lower. Exceeding the specified current value may cause damage to the output circuit.

● [Output]

Object signals:

- No.20 to 27 pins: Connect the COMOUT1 and COMIN0 terminals when using these signals.

Item	Specifications
Output voltage	12 to 24 VDC $\pm 10\%$
Load current*1	45 mA max.
ON residual voltage	2 V max.
OFF leakage current	0.2 mA max.

*1. The load current must be the specified current value or lower. Exceeding the specified current value may cause damage to the output circuit.

● Connection

Connect the parallel I/O cable with more than the minimum bending radius.

● Pin Assignment

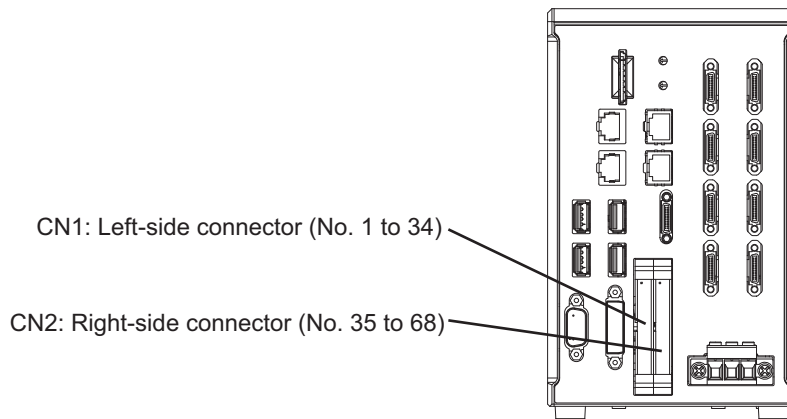

Cable, I/O connector and Terminal Block

Use the following parallel I/O cable.

Name	Model	Description	Remark
Parallel I/O cable	XW2Z-S013-□	Specialized for FH series Cable length: 2 m, 5 m Min. bending radius: 10 mm	<ul style="list-style-type: none"> Two these cables are needed to use all I/O signals. One side of this cable is flat cable and another side of it is a connector. Connect the parallel I/O cable with securing the minimum bending radius and more. Cable length is set to □ in the model number. (2 = 2 m, 5 = 5 m)
Parallel I/O cable for Connector-Terminal Conversion Unit	XW2Z-□□ □EE	Specialized for FH series Cable length: 0.5 m, 1 m, 1.5 m, 2 m, 3 m, 5 m Min. bending radius: 83.2 mm	<ul style="list-style-type: none"> Two these cables are needed to use all I/O signals. One side of this cable is flat cable and another side of it is a connector. Connect the parallel I/O cable with securing the minimum bending radius and more. Cable length is set to □ in the model number. (050 = 0.5 m, 100 = 1 m, 150 = 1.5 m, 2 = 2 m, 300 = 3 m, 500 = 5 m) Connectable Connector-Terminal Block Conversion Unit : XW2R-□34GD-T
Connector-Terminal Conversion Unit for general-purpose	XW2R-□34GD-T	-	The following is set to □ in the model number. For details, refer to the <i>XW2R Series catalog (Cat. No. G077)</i> .

● XW2Z-S013-□

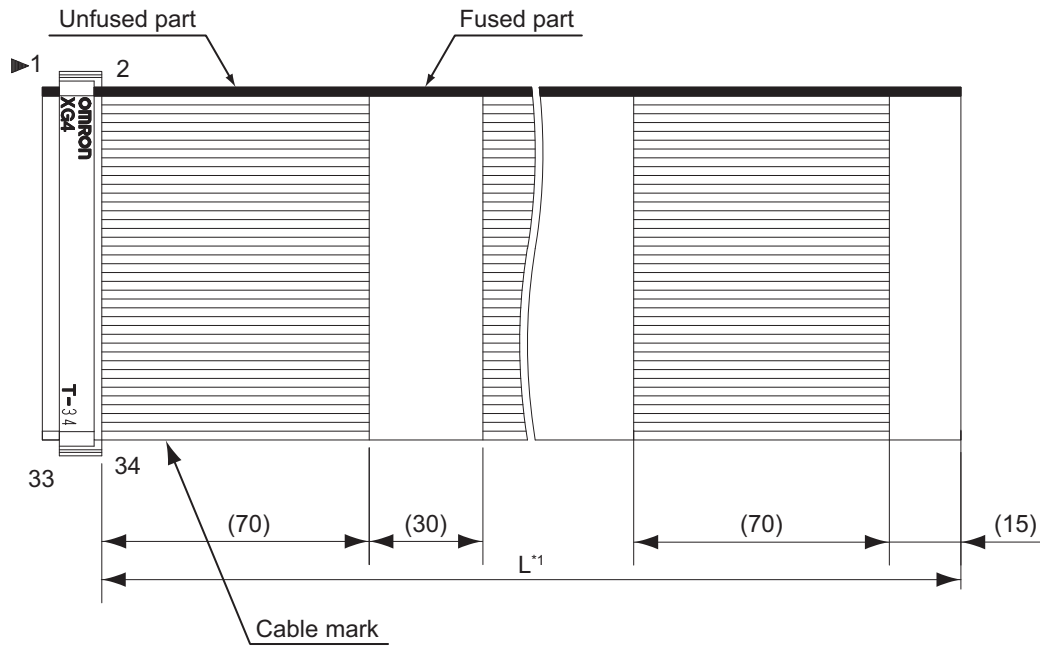

*1. Cable is available in 2 m/5 m.

Pin Layout

Terminal assignments and signal names should be set according to the FH Sensor Controller's operation mode settings. Verify that the wiring conforms to that.



Additional Information

For Operation Mode, refer to the *Setting the Operation Mode* in the *Vision Sensor FH/FHV Series User's Manual (Cat. No. Z365)*.

No.	I/O	XW2Z-S013-□ Wire color	XW2R-□34GD-T Connector-Terminal Block Conversion Units, General-purpose devices	Signal name			
				1-line mode	2-line random mode	3- to 4-line random mode	5- to 8-line random mode
CN1							
1	-	Red	A1	COMIN0			
2	-	Gray	B1	COMIN1			
3	-	Gray	A2	Vacant			
4	IN	Gray	B2	STEP0/ ENC- TRIG_Z0*1	STEP0/ ENC- TRIG_Z0*2	STEP0	STEP0
5	IN	Green	A3	Not used*3	STEP1/ ENC- TRIG_Z1*2	STEP1	STEP1
6	IN	Gray	B3	Not used*3	Not used*3	STEP2	STEP2

No.	I/O	XW2Z-S013-□ Wire color	XW2R-□34GD-T Connector-Terminal Block Conversion Units, General-purpose devices	Signal name			
				1-line mode	2-line random mode	3- to 4-line random mode	5- to 8-line random mode
7	IN	Gray	A4	Not used ^{*3}	Not used ^{*3}	STEP3	STEP3
8	IN	Gray	B4	ENC-TRIG_A0 ^{*1}	ENC-TRIG_A0 ^{*1}	Not used ^{*3}	Not used ^{*3}
9	IN	Gray	A5	Not used ^{*3}	Not used ^{*3}	Not used ^{*3}	STEP4
10	IN	Green	B5	Not used ^{*3}	Not used ^{*3}	Not used	STEP5
11	IN	Gray	A6	Not used ^{*3}	ENC-TRIG_A1	Not used	STEP6
12	IN	Gray	B6	Not used ^{*3}	ENC-TRIG_B1 ^{*2}	Not used	STEP7
13	IN	Gray	A7	ENC-TRIG_B0 ^{*1}	ENC-TRIG_B0 ^{*2}	Not used ^{*3}	Not used ^{*3}
14	IN	Gray	B7	Not used ^{*3}	DILINE0		
15	OUT	Green	A8	RUN0	RUN0	RUN0	READY0
16	OUT	Gray	B8	READY0	READY0	READY0	BUSY0
17	OUT	Gray	A9	BUSY0	BUSY0	BUSY0	OR0
18	OUT	Gray	B9	OR0	OR0	OR0	READY1
19	OUT	Gray	A10	ERROR0	ERROR0	ERROR0	BUSY1
20	OUT	Green	B10	STGOUT0 ^{*4} /SHTOUT0			
21	OUT	Gray	A11	STGOUT1 ^{*4} /SHTOUT1			
22	OUT	Gray	B11	STGOUT2 ^{*4} /SHTOUT2			
23	OUT	Gray	A12	STGOUT3 ^{*4} /SHTOUT3			
24	OUT	Gray	B12	STGOUT4 ^{*4} /SHTOUT4			
25	OUT	Green	A13	STGOUT5 ^{*4} /SHTOUT5			
26	OUT	Gray	B13	STGOUT6 ^{*4} /SHTOUT6			
27	OUT	Gray	A14	STGOUT7 ^{*4} /SHTOUT7			
28	OUT	Gray	B14	Not used ^{*3}	RUN1	RUN1	OR1
29	OUT	Gray	A15	Not used ^{*3}	READY1	READY1	READY2
30	OUT	Green	B15	Not used ^{*3}	BUSY1	BUSY1	BUSY2
31	OUT	Gray	A16	Not used ^{*3}	OR1	OR1	OR2
32	OUT	Gray	B16	Not used ^{*3}	ERROR1	ERROR1	READY3
33	-	Gray	A17	COMOUT0			
34	-	Gray	B17	COMOUT1			
CN2							
35	-	Red	A1	COMIN2			
36	-	Gray	B1	Vacant			
37	-	Gray	A2	DSA0	DSA0	DILINE1	DILINE1
38	IN	Gray	B2	Not used ^{*3}	DSA1	Not used ^{*3}	DILINE2

No.	I/O	XW2Z-S013-□ Wire color	XW2R-□34GD-T Connector-Terminal Block Conversion Units, General-purpose devices	Signal name			
				1-line mode	2-line random mode	3- to 4-line random mode	5- to 8-line random mode
39	IN	Green	A3	DI0			
40	IN	Gray	B3	DI1			
41	IN	Gray	A4	DI2			
42	IN	Gray	B4	DI3			
43	IN	Gray	A5	DI4			
44	IN	Green	B5	DI5			
45	IN	Gray	A6	DI6			
46	IN	Gray	B6	DI7			
47	IN	Gray	A7	Vacant			
48	IN	Gray	B7	ACK			
49	OUT	Green	A8	GATE0	GATE0	RUN2	BUSY3
50	OUT	Gray	B8	Not used*3	GATE1	READY2	OR3
51	OUT	Gray	A9	DO0	DO0	BUSY2	READY4
52	OUT	Gray	B9	DO1	DO1	OR2	BUSY4
53	OUT	Gray	A10	DO2	DO2	ERROR2	OR4
54	OUT	Green	B10	DO3	DO3	RUN3	READY5
55	OUT	Gray	A11	DO4	DO4	READY3	BUSY5
56	OUT	Gray	B11	DO5	DO5	BUSY3	OR5
57	OUT	Gray	A12	DO6	DO6	OR3	READY6
58	OUT	Gray	B12	DO7	DO7	Not used*3	BUSY6
59	OUT	Green	A13	DO8	DO8	Not used*3	OR6
60	OUT	Gray	B13	DO9	DO9	Not used*3	READY7
61	OUT	Gray	A14	DO10	DO10	Not used*3	BUSY7
62	OUT	Gray	B14	DO11	DO	Not used*3	OR7
63	OUT	Gray	A15	DO12	DO12	Not used*3	Not used*3
64	OUT	Green	B15	DO13	DO13	Not used*3	Not used*3
65	OUT	Gray	A16	DO14	DO14	Not used*3	Not used*3
66	OUT	Gray	B16	DO15	DO15	Not used*3	ERROR*5
67	-	Gray	A17	COMOUT2			
68	-	Gray	B17	COMOUT3			

Remarks:

COMIN0 to 2: Common for input signals, COMOUT0 to 3: Common for output signals,
 DI0 to 7: Command inputs, DILINE0 to 2: Command inputs (Line specified) ,
 ENCTRIG_A0 to 1: Encoder trigger input for phase A, ENCTRIG_B0 to 1: Encoder trigger input for phase B,
 ENCTRIG_Z0 to 1: Encoder trigger input for phase Z, STEP0 to 7: Measurement trigger,
 ACK: Instruction execution complete flag, BUSY0 to 7: ON during processing,
 DO0 to 15: Data outputs, ERROR: ON when an error occurs*5,
 ERROR0 to 3: ON when an error occurs, GATE0 to 1: ON during set output time,
 OR0 to 7: Overall judgment results, READY0 to 7: ON when image input is permitted,

RUN0 to 3: ON when switched to output specified layout,
 SHTOUT0 to 7: Shutter output signals, STGOUT0 to 7: Strobe trigger signals*⁴

- *1. Use the STEP signal when using measurement trigger inputs. Use the ENCTRIG_A0/B0/Z0 when using encoder inputs
- *2. When using one measurement trigger and one encoder input in the 2-line random mode, use ENCTRIG_A0/B0/Z0 and STEP1.
- *3. Do not connect anything for "Not used".
- *4. This signal is used when the strobe signal is used for the Sensor Controller.
- *5. The ERROR signal is shared among No.1 to 8 line.

Internal Specifications for Parallel Interface

The parallel interface can be used for both NPN and PNP. Connect the pins properly according to the specifications of external devices.

● [Input]

Object signals:

- No.14 pin: Use the COMIN1 terminal when using these signals.
- No.37 to 46 pins: Use the COMIN2 terminal when using these signals.

a) Internal specifications for NPN connection

Item	Specifications
Internal circuit diagram	

b) Internal specifications for PNP connection

Item	Specifications
Internal circuit diagram	

● [Input]

Object signals:

- No.4 to 6, 9 to 11 pins: Use the COMIN1 terminal when using these signals.
- No.7, 8, 12, 13 pins: Use the COMIN0 terminal when using these signals.

a) Internal specifications for NPN connection

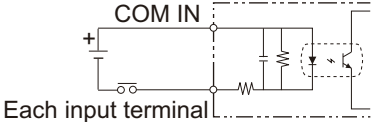
Item	Specifications
Internal circuit diagram	 <p>Each input terminal</p>

b) Internal specifications for PNP connection

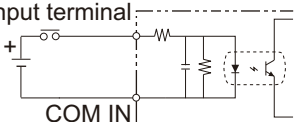
Item	Specifications
Internal circuit diagram	 <p>Each input terminal</p>

● [Output]

Object signals:

- No.15 to 19 pin, No.28 to 32pin: Use the COMOUT0 terminal when using these signals.
- No.48 to 57 pins: Use the COMOUT2 terminal when using these signals.
- No.58 to 66 pins: Use the COMOUT3 terminal when using these signals.

a) Internal specifications for NPN connection

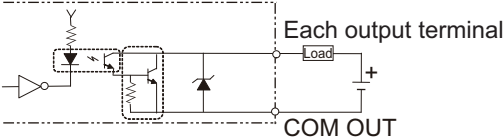
Item	Specifications
Internal circuit diagram	 <p>Each output terminal</p>

b) Internal specifications for PNP connection

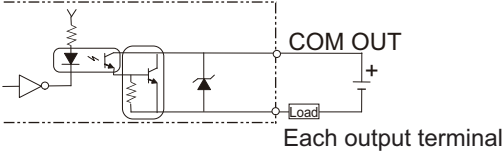
Item	Specifications
Internal circuit diagram	 <p>Each output terminal</p>

● [Output]

Object signals:

- No.20 to 27 pins: Connect the COMOUT1 and COMIN0 terminals when using these signals.

a) Internal specifications for NPN connection

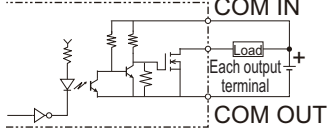
Item	Specifications
Internal circuit diagram	

b) Internal specifications for PNP connection

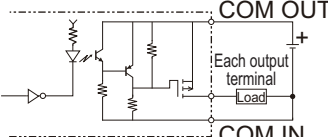
Item	Specifications
Internal circuit diagram	

6-1-3 FH-L Series

The parallel interface can be used for both NPN and PNP. Connect the pins properly according to the specifications of external devices.

Interface Specification

Specifications vary depending on the pin's role.

● [Input]

Object signals:

- No.37, 39 to 46 pins: Use the COMIN2 terminal when using these signals.

Item	Specifications
Input voltage	12 to 24 VDC $\pm 10\%$
ON current*1	5 mA min.
ON voltage*1	8.8 V min.
OFF current*2	0.5 mA max.
OFF voltage*2	1.1 V max.
ON delay	5 ms max.
OFF delay	0.7 ms max.

*1. ON current and ON voltage:

These are the current value or voltage value to turn ON from OFF. The value for the ON voltage is the potential difference between COMIN and each input terminal.

*2. OFF current and OFF voltage:

These are the current value or voltage value to turn OFF from ON. The value for the OFF voltage is the potential difference between COMIN and each input terminal.

● [Input]

Object signals:

- No.4 pin: Use the COMIN1 terminal when using these signals.

Item	Specifications
Input voltage	12 to 24 VDC $\pm 10\%$
ON current*1	5 mA min.
ON voltage*1	8.8 V min.
OFF current*2	0.5 mA max.
OFF voltage*2	0.8 V max.
ON delay	0.1 ms max.
OFF delay	0.1 ms max.

*1. ON current and ON voltage:

These are the current value or voltage value to turn ON from OFF. The value for the ON voltage is the potential difference between COMIN and each input terminal.

*2. OFF current and OFF voltage:

These are the current value or voltage value to turn OFF from ON. The value for the OFF voltage is the potential difference between COMIN and each input terminal.

● [Output]

Object signals:

- No.15 to 19 pin: Use the COMOUT0 terminal when using these signals.
- No.49, 51 to 57 pins: Use the COMOUT2 terminal when using these signals.
- No.58 to 66 pins: Use the COMOUT3 terminal when using these signals.

Item	Specifications
Output voltage	12 to 24 VDC \pm 10 %
Load current*1	45 mA max.
ON residual voltage	2 V max.
OFF leakage current	0.2 mA max.

*1. The load current must be the specified current value or lower. Exceeding the specified current value may cause damage to the output circuit.

● [Output]

Object signals:

- No.20 to 23 pins:Use COMOUT1 and COMIN0 when using these signals.

Item	Specifications
Output voltage	12 to 24 VDC \pm 10 %
Load current*1	45 mA max.
ON residual voltage	2 V max.
OFF leakage current	0.2 mA max.

*1. The load current must be the specified current value or lower. Exceeding the specified current value may cause damage to the output circuit.

● Connection

Connect the parallel I/O cable with more than the minimum bending radius.

● Pin AssignmentCN1

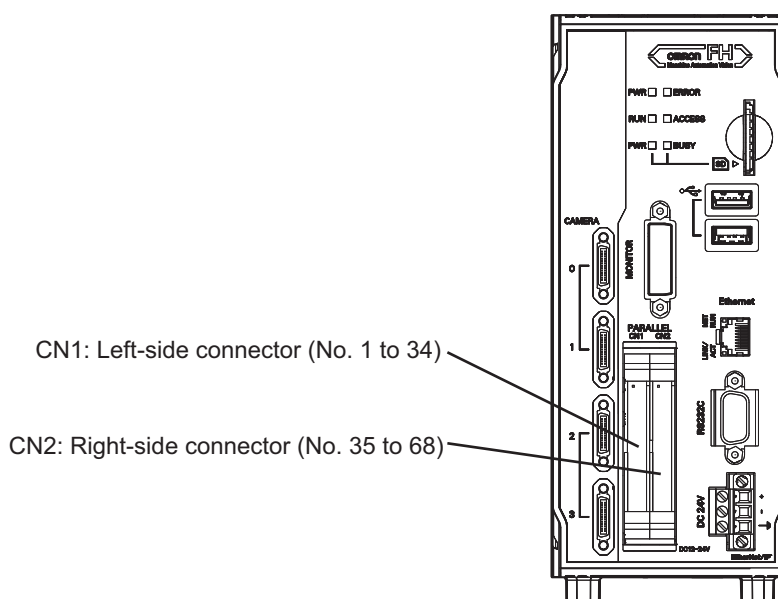

CN1: Left-side connector (No. 1 to 34)

CN2: Right-side connector (No. 35 to 68)

Cable, I/O connector and Terminal Block

Use the following parallel I/O cable.

Name	Model	Description	Remark
Parallel I/O cable	XW2Z-S013-□	Specialized for FH series Cable length: 2 m, 5 m Min. bending radius: 10 mm	<ul style="list-style-type: none"> Two these cables are needed to use all I/O signals. One side of this cable is flat cable and another side of it is a connector. Connect the parallel I/O cable with securing the minimum bending radius and more. Cable length is set to □ in the model number. (2 = 2 m, 5 = 5 m)
Parallel I/O cable for Connector-Terminal Conversion Unit	XW2Z-□□ □EE	Specialized for FH series Cable length: 0.5 m, 1 m, 1.5 m, 2 m, 3 m, 5 m Min. bending radius: 83.2 mm	<ul style="list-style-type: none"> Two these cables are needed to use all I/O signals. One side of this cable is flat cable and another side of it is a connector. Connect the parallel I/O cable with securing the minimum bending radius and more. Cable length is set to □ in the model number. (050 = 0.5 m, 100 = 1 m, 150 = 1.5 m, 2 = 2 m, 300 = 3 m, 500 = 5 m) Connectable Connector-Terminal Block Conversion Unit : XW2R-□34GD-T
Connector-Terminal Conversion Unit for general-purpose	XW2R-□34GD-T	-	The following is set to □ in the model number. For details, refer to the <i>XW2R Series catalog (Cat. No. G077)</i> .

● XW2Z-S013-□

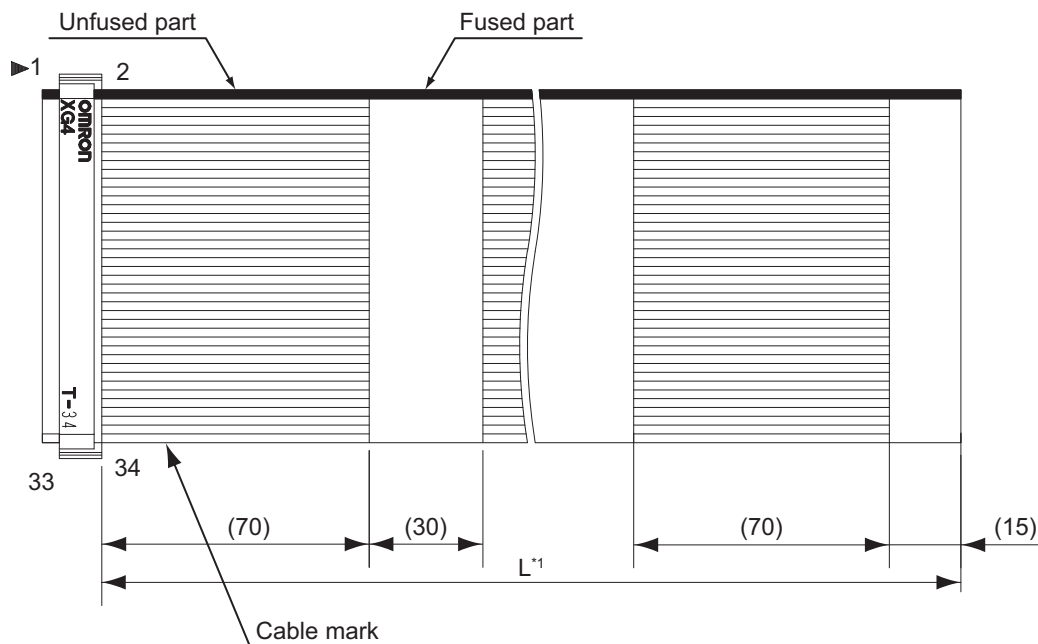

*1. Cable is available in 2 m/5 m.

Pin Layout

No.	I/O	XW2Z-S013-□ Wire color	XW2R-□34GD- T Connector- Terminal Block Conversion Units, General- purpose devi- ces	Signal name
CN1				
1	-	Red	A1	COMIN0
2	-	Gray	B1	COMIN1
3	-	Gray	A2	Vacant
4	IN	Gray	B2	STEP0
5	IN	Green	A3	Vacant
6	IN	Gray	B3	Vacant
7	IN	Gray	A4	Vacant
8	IN	Gray	B4	Vacant
9	IN	Gray	A5	Vacant
10	IN	Green	B5	Vacant
11	IN	Gray	A6	Vacant
12	IN	Gray	B6	Vacant
13	IN	Gray	A7	Vacant
14	IN	Gray	B7	Vacant
15	OUT	Green	A8	RUN0
16	OUT	Gray	B8	READY0
17	OUT	Gray	A9	BUSY0
18	OUT	Gray	B9	OR0
19	OUT	Gray	A10	ERROR0
20	OUT	Green	B10	STGOUT0/SHTOUT0
21	OUT	Gray	A11	STGOUT1
22	OUT	Gray	B11	STGOUT2
23	OUT	Gray	A12	STGOUT3
24	OUT	Gray	B12	Vacant
25	OUT	Green	A13	Vacant
26	OUT	Gray	B13	Vacant
27	OUT	Gray	A14	Vacant
28	OUT	Gray	B14	Vacant
29	OUT	Gray	A15	Vacant
30	OUT	Green	B15	Vacant
31	OUT	Gray	A16	Vacant
32	OUT	Gray	B16	Vacant
33	-	Gray	A17	COMOUT0
34	-	Gray	B17	COMOUT1
CN2				
35	-	Red	A1	COMIN2
36	-	Gray	B1	Vacant
37	IN	Gray	A2	DSA0

No.	I/O	XW2Z-S013-□ Wire color	XW2R-□34GD- T Connector- Terminal Block Conversion Units, General- purpose devi- ces	Signal name
38	IN	Gray	B2	Vacant
39	IN	Green	A3	DI0
40	IN	Gray	B3	DI1
41	IN	Gray	A4	DI2
42	IN	Gray	B4	DI3
43	IN	Gray	A5	DI4
44	IN	Green	B5	DI5
45	IN	Gray	A6	DI6
46	IN	Gray	B6	DI7
47	-	Gray	A7	Vacant
48	OUT	Gray	B7	ACK
49	OUT	Green	A8	GATE0
50	OUT	Gray	B8	Vacant
51	OUT	Gray	A9	DO0
52	OUT	Gray	B9	DO1
53	OUT	Gray	A10	DO2
54	OUT	Green	B10	DO3
55	OUT	Gray	A11	DO4
56	OUT	Gray	B11	DO5
57	OUT	Gray	A12	DO6
58	OUT	Gray	B12	DO7
59	OUT	Green	A13	DO
60	OUT	Gray	B13	DO9
61	OUT	Gray	A14	DO10
62	OUT	Gray	B14	DO11
63	OUT	Gray	A15	DO12
64	OUT	Green	B15	DO13
65	OUT	Gray	A16	DO14
66	OUT	Gray	B16	DO15
67	-	Gray	A17	COMOUT2
68	-	Gray	B17	COMOUT3

COMIN0 to 2: Common for input signals, COMOUT0 to 3: Common for output signals,
DI0 to 7: Command inputs, DSA0: Data send request,
STEP0: Measurement trigger 0, ACK: Instruction execution complete flag,
BUSY0: ON during processing, DO0 to 15: Data outputs,
ERROR0: ON when an error occurs, GATE0: ON during set output time,
OR0: Overall judgment result, READY0: ON when image input is permitted,
RUN0: ON when switched to output specified layout,
SHTOUT0: Shutter output signal, STGOUT0 to 3: Strobe trigger signals

Note: When the signal is vacant, do not connect anything.

Internal Specifications for Parallel Interface

The parallel interface can be used for both NPN and PNP. Connect the pins properly according to the specifications of external devices.

● [Input]

Object signals:

- No.37, 39 to 46 pin: Use the COMIN2 terminal when using these signals.

a) Internal specifications for NPN connection

Item	Specifications
Internal circuit diagram	<p>Each input terminal</p>

b) Internal specifications for PNP connection

Item	Specifications
Internal circuit diagram	<p>Each input terminal</p> <p>COM IN</p>

● [Input]

Object signals:

- No.4 pin: Use the COMIN1 terminal when using these signals.

a) Internal specifications for NPN connection

Item	Specifications
Internal circuit diagram	<p>Each input terminal</p>

b) Internal specifications for PNP connection

Item	Specifications
Internal circuit diagram	<p>Each input terminal</p> <p>COM IN</p>

● [Output]

Object signals:

- No. 15 to 19 pin: Use the COMOUT0 terminal when using these signals.

- No. 48, 49, 51 to 57 pins: Use the COMOUT2 terminal when using these signals.
- No.58 to 66 pins: Use the COMOUT3 terminal when using these signals.

a) Internal specifications for NPN connection

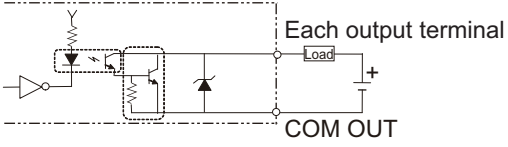
Item	Specifications
Internal circuit diagram	

b) Internal specifications for PNP connection

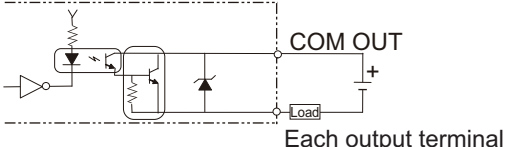
Item	Specifications
Internal circuit diagram	

● [Output]

Object signals:

- No.20 to 23 pins: Connect the COMOUT1 and COMIN0 terminals when using these signals.

a) Internal specifications for NPN connection

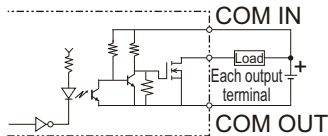
Item	Specifications
Internal circuit diagram	

b) Internal specifications for PNP connection

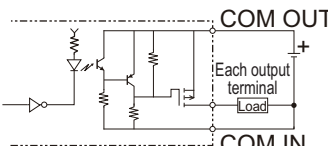
Item	Specifications
Internal circuit diagram	

6-1-4 Other (Parallel Converter Cable)

When you change to connect the F series, FZ5 series, or FZ5-L series to FH series Sensor Controller, you can convert by using the appropriate parallel converter cable of FH-VPX series under the usable condition.

Corresponding model		Con-vertible	Applicable parallel conversion cable	Required conditions
FZ□ series		Yes	FH-VPX-FZ	<ul style="list-style-type: none"> RESET is not used. *1 The same power supply is shared in COMIN and COMOUT.
FZ□-L35□ series		Yes	FH-VPX-FZL	<ul style="list-style-type: none"> RESET is not used. *1
F160 series	F160-C10	Yes	FH-VPX-F160	<ul style="list-style-type: none"> RESET is not used. *1 The same power supply is shared in COMIN and COMOUT. Do not use DI5 and DI6.
	F160-C10CP	No	-	-
	F160-C10CF	No	-	-
F210 series	F210-C10	Yes	FH-VPX-F210	<ul style="list-style-type: none"> RESET is not used. *1 The same power supply is shared in COMIN and COMOUT. Do not use DI8 and DI9.
	F210-C10-ETN	Yes	FH-VPX-F210	
F500 series	F500-C10	Yes	FH-VPX-F210	
F250 series		No	-	-
F270 series		No	-	-

*1. If the RESET signal becomes unavailable by conversion even though the signal has been used, but it causes no problem, the conversion is possible by satisfying other required conditions.

FH-VPX-FZ

● Connection Structure (FH-VPX-FZ)

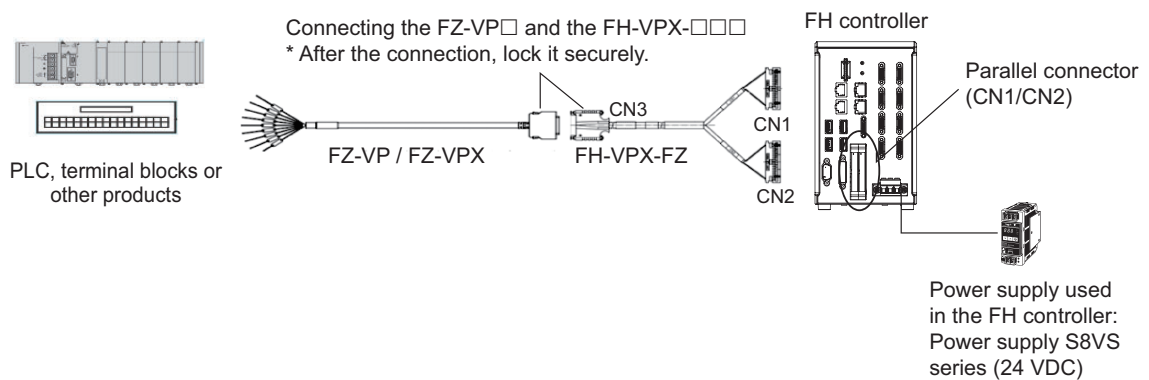

Connector No.	Connection destination	Note
CN1	Connect to the parallel port CN1 on the Sensor Controller.	Even if you connect the CN1 and CN2 reversely by mistake, it does not work but will not be damaged.
CN2	Connect to the parallel port CN2 on the Sensor Controller.	
CN3	Connect to the parallel I/O cable, FZ-VP□	-

● Cable (FH-VPX-FZ)

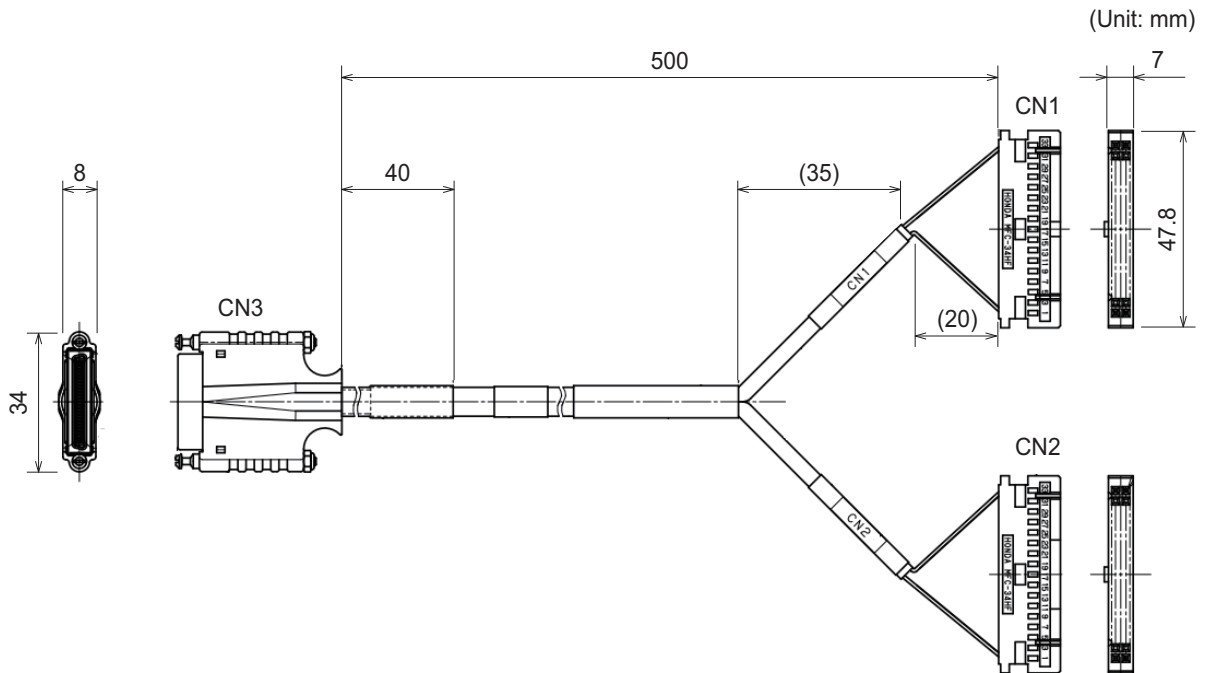

● Pin Layout (FH-VPX-FZ)

Connection connector for FZ-VP□		Connection connector on the Sensor Controller		
Pin No.	Signal name	Pin No.		Signal name
CN3		CN1	CN2	
1	COMIN	1	-	COMIN0
		2	-	COMIN1
		-	1	COMIN2
2	ENCTRIG_A1	11	-	STEP1/ENCTRIG_A1
3	ENCTRIG_B1	12	-	STEP1/ENCTRIG_B1
4	STEP1/ENCTRIG_Z1	5	-	STEP1/ENCTRIG_Z1
5	DSA1	-	4	DSA1
6	DI1	-	6	DI1
7	DI3	-	8	DI3
8	DI5	-	10	DI5
9	DI7	-	12	DI7
10	STGOUT1	21	-	STGOUT1/SHTOUT1
11	STGOUT3	23	-	STGOUT3
12	ERROR	19	-	ERROR0
13	COMOUT1	33	-	COMOUT0
		34	-	COMOUT1
14	GATE1	-	16	GATE1
15	OR1	31	-	OR1
16	READY1	29	-	READY1
17	COMOUT2	-	33	COMOUT2
18	DO1	-	18	DO1
19	DO3	-	20	DO3
20	DO5	-	22	DO5

Connection connector for FZ-VP□		Connection connector on the Sensor Controller		
Pin No.	Signal name	Pin No.		Signal name
CN3		CN1	CN2	
21	DO7	-	24	DO7
22	DO9	-	26	DO9
23	DO11	-	28	DO11
24	DO13	-	30	DO13
25	COMOUT3	-	34	COMOUT3
26	RESET	-	-	-
27	ENCTRIG_A0	8	-	ENCTRIG_A0
28	ENCTRIG_B0	13	-	ENCTRIG_B0
29	STEP0/ENCTRIG_Z0	4	-	STEP0/ENCTRIG_Z0
30	DSA0	-	3	DSA0
31	DI0	-	5	DI0
32	DI2	-	7	DI2
33	DI4	-	9	DI4
34	DI6	-	11	DI6
35	STGOUT0	20	-	STGOUT0
36	STGOUT2	22	-	STGOUT2
37	RUN0	15	-	RUN0
38	BUSY0	17	-	BUSY0
39	GATE0	-	15	GATE0
40	OR0	18	-	OR0
41	READY0	16	-	READY0
42	DO0	-	17	DO0
43	DO2	-	19	DO2
44	DO4	-	21	DO4
45	DO6	-	23	DO6
46	DO8	-	25	DO8
47	DO10	-	27	DO10
48	DO12	-	29	DO12
49	DO14	-	31	DO14
50	DO15	-	32	DO15

Note: COMOUT is unified in 1 system with shorting PIN No.13, No.17, and No.25.

FH-VPX-FZL

● Connection Structure (FH-VPX-FZL)

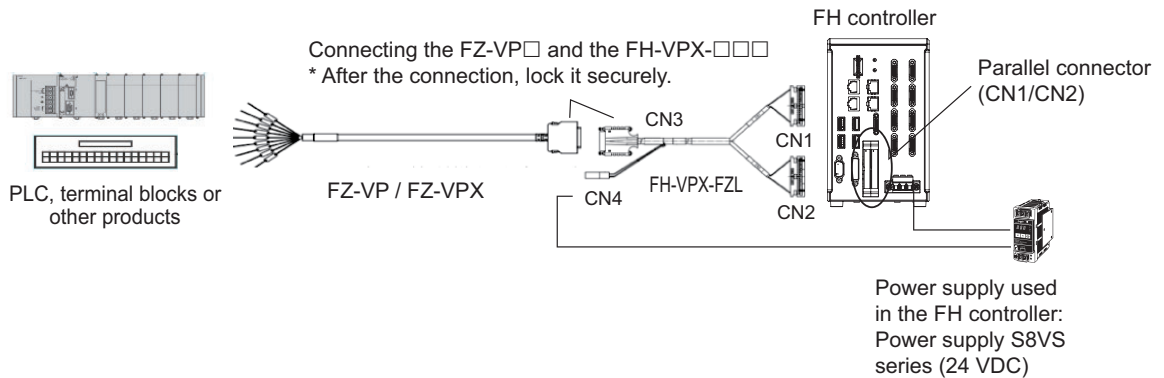

Connector No.	Connection destination	Note
CN1	Connect to the parallel port CN1 on the Sensor Controller.	Even if you connect the CN1 and CN2 reversely by mistake, it does not work but will not be damaged.
CN2	Connect to the parallel port CN2 on the Sensor Controller.	
CN3	Connect to the parallel I/O cable, FZ-VP□	-
CN4	Connect to 24 V power source depending on the NPN/PNP polarity as below table. *1	<ul style="list-style-type: none"> When the power source and DIO are non-isolated and no problem: Possible to connect the same power source for the FH series. When you want to isolate the power source and DIO: The power source for the FH series cannot be used. Use another power source. Recommendations: S8VS series, 24 VDC

*1. COM terminal polarity in NPN/PNP:

	NPN	PNP
COMIN	+V	-V
COMOUT	-V	+V

● Cable (FH-VPX-FZL)

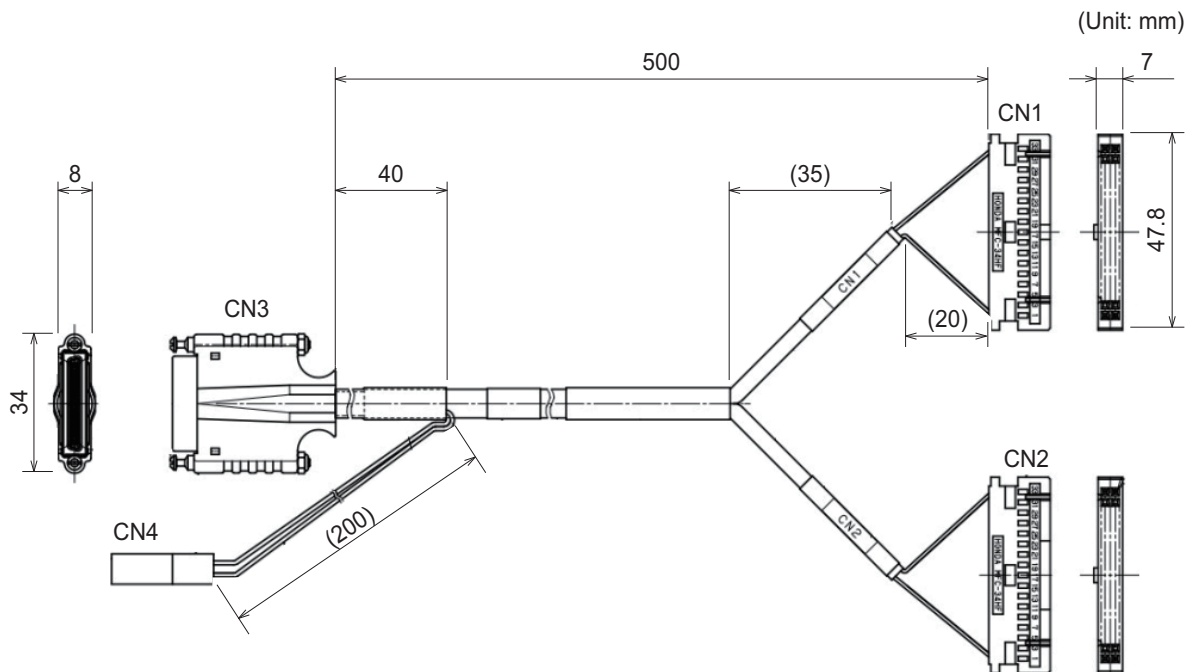

● Pin Layout (FH-VPX-FZL)

Connection connector for FZ-VP□			Connection connector on the Sensor Controller		
Pin No.		Signal name	Pin No.		Signal name
CN3	CN4		CN1	CN2	
-	1	-	1	-	COMIN0
			2	-	COMIN1
			-	1	COMIN2
	2	-	33	-	COMOUT0
			34	-	COMOUT1
	2	-	-	33	COMOUT2
	2	-	-	33	COMOUT3
A1	-	N/A	-	-	-
A2		N/A	-	-	-
A3		N/A	-	-	-
A4		N/A	-	-	-
A5		N/A	-	-	-
A6		DI1	-	6	DI1
A7		DI3	-	8	DI3
A8		DI5	-	10	DI5
A9		DI7	-	12	DI7
A10		STGOUT1	21	-	STGOUT1/SHTOUT1
A11		STGOUT2	23	-	STGOUT3
A12		ERROR	19	-	ERROR0
A13		N/A	-	-	-
A14		N/A	-	-	-
A15		N/A	-	-	-
A16		N/A	-	-	-

Connection connector for FZ-VP□			Connection connector on the Sensor Controller		
Pin No.		Signal name	Pin No.		Signal name
CN3	CN4		CN1	CN2	
A17		N/A	-	-	-
A18		DO1	-	18	DO1
A19		DO3	-	20	DO3
A20		DO5	-	22	DO5
A21		DO7	-	24	DO7
A22		DO9	-	26	DO9
A23		DO11	-	28	DO11
A24		DO13	-	30	DO13
A25		N/A	-	-	-
B1	-	RESET	-	-	-
B2		N/A	-	-	-
B3		N/A	-	-	-
B4		STEP0	4	-	STEP0/ENCTRIG_Z0
B5		DSA0	-	3	DSA0
B6		DI0	-	5	DI0
B7		DI2	-	7	DI2
B8		DI4	-	9	DI4
B9		DI6	-	11	DI6
B10		STGOUT0	20	-	STGOUT0/SHTOUT0
B11		STGOUT2	22	-	STGOUT2
B12		RUN0/BUSY1	15	-	RUN0
B13		BUSY0	17	-	BUSY0
B14		GATE0	-	15	GATE0
B15		OR0	18	-	OR0
B16		READY0	16	-	READY0
B17		DO0	-	17	DO0
B18		DO2	-	19	DO2
B19		DO4	-	21	DO4
B20		DO6	-	23	DO6
B21		DO8	-	25	DO8
B22		DO10	-	27	DO10
B23		DO12	-	29	DO12
B24		DO14	-	31	DO14
B25		DO15	-	32	DO15

- Note:
1. PIN_No.1 of CN4 is unified in 1 system with shorting COMIN0-2 of FH series.
 2. PIN_No.2 of CN4 is unified in 1 system with shorting COMOUT0-3 of FH series.

FH-VPX-F160

● Connection Structure (FH-VPX-F160)

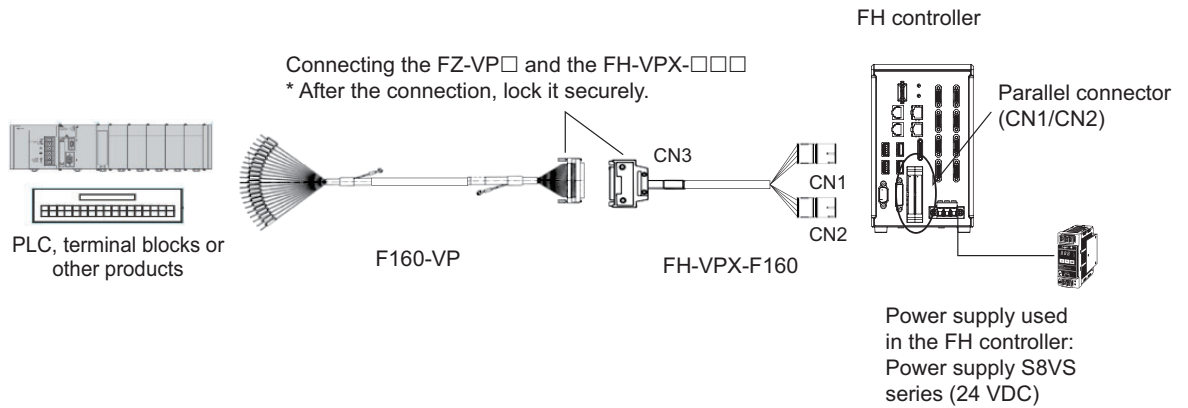

Connector No.	Connection destination	Note
CN1	Connect to the parallel port CN1 on the Sensor Controller.	Even if you connect the CN1 and CN2 reversely by mistake, it does not work but will not be damaged.
CN2	Connect to the parallel port CN2 on the Sensor Controller.	
CN3	Connect to the Parallel I/O cable F160-VP.	-

● Cable (FH-VPX-F160)

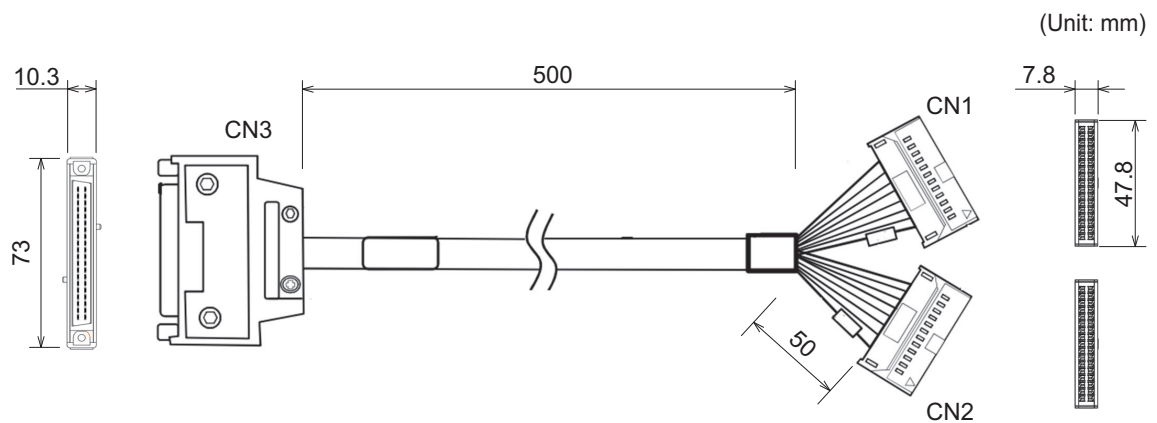

● Pin Layout (FH-VPX-F160)

Connection connector for F160-VP		Connection connector on the Sensor Controller		
Pin No.	Signal name	Pin No.		Signal name
CN3		CN1	CN2	
A1	RESET	N/A		-
A2	STEP	4	-	STEP0/ENCTRIG_Z0
A3	DI0	-	5	DI0
A4	DI2	-	7	DI2
A5	DI4	-	9	DI4
A6	DI6	-	-	-

Connection connector for F160-VP		Connection connector on the Sensor Controller		
Pin No.	Signal name	Pin No.		Signal name
CN3		CN1	CN2	
A7	DI8	-	45	DI6
A8	STGOUT0	20	-	STGOUT0/SHTOUT0
A9	RUN	15	-	RUN0
A10	BUSY	17	-	BUSY0
A11	OR	18	-	OR0
A12	DO0	-	17	DO0
A13	DO2	-	19	DO2
A14	DO4	-	21	DO4
A15	DO6	-	23	DO6
A16	DO8	-	25	DO8
A17	DO9	-	26	DO9
A18	DO11	-	28	DO11
A19	DO13	-	30	DO13
A20	DO15	-	32	DO15
B1	COMIN	1	-	COMIN0
		2	-	COMIN1
		-	1	COMIN2
B2	DSA	-	3	DSA0
B3	DI1	-	6	DI1
B4	DI3	-	8	DI3
B5	DI5	-	-	-
B6	DI7	-	10	DI5
B7	DI9	-	12	DI7
B8	STGOUT1	21	-	STGOUT1/SHTOUT1
B9	ERROR	19	-	ERROR0
B10	GATE	-	15	GATE0
B11	COMOUT1	33	-	COMOUT
B12	DO1	-	18	DO1
B13	DO3	-	20	DO3
B14	DO5	-	22	DO5
B15	DO7	-	24	DO7
B16	COMOUT2	34	-	COMOUT
B17	DO10	-	27	RUN0
B18	DO12	-	29	BUSY0
B19	DO14	-	31	GATE0
B20	COMOUT3	-	33	COMOUT
		-	34	

Note: COMOUT is unified in 1 system with shorting B11, B16, and B20.

FH-VPX-F210

● Connection Structure (FH-VPX-F210)

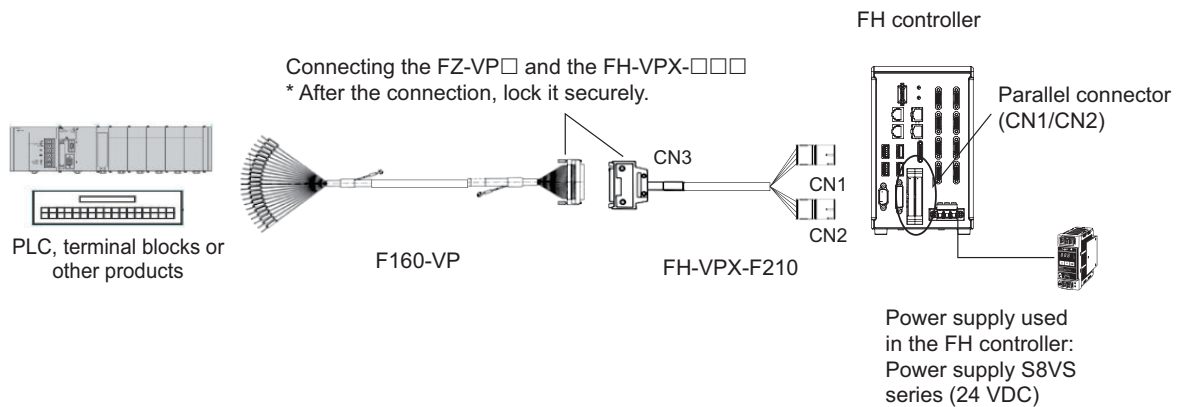

Connector No.	Connection destination	Note
CN1	Connect to the parallel port CN1 on the Sensor Controller.	Even if you connect the CN1 and CN2 reversely by mistake, it does not work but will not be damaged.
CN2	Connect to the parallel port CN2 on the Sensor Controller.	
CN3	Connect to the Parallel I/O cable F160-VP.	-

● Cable (FH-VPX-F210)

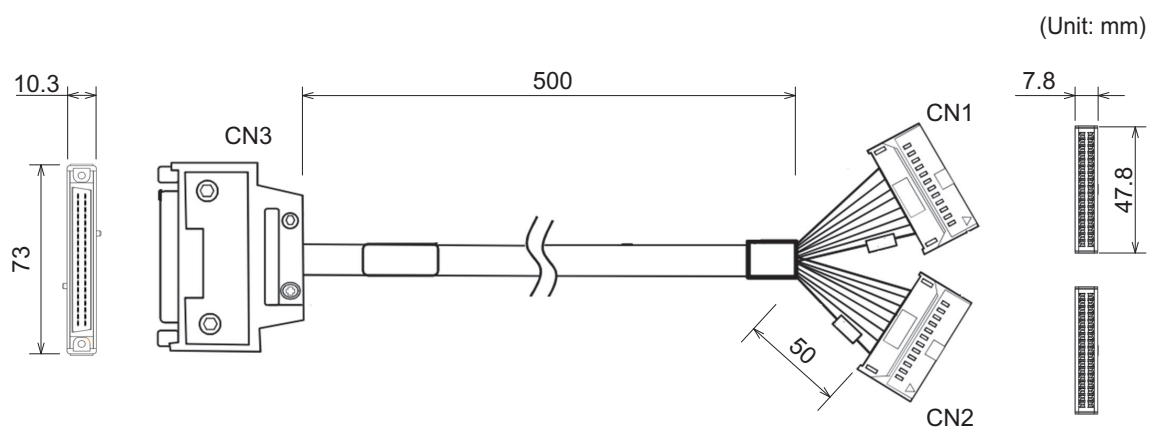

● PIN Layout (FH-VPX-F210)

Connection connector for F160-VP		Connection connector on the Sensor Controller		
Pin No.	Signal name	Pin No.		Signal name
CN3		CN1	CN2	
A1	RESET	N/A		-
A2	STEP	4	-	STEP0/ENCTRIG_Z0
A3	DI0	-	5	DI0
A4	DI2	-	7	DI2
A5	DI4	-	9	DI4
A6	DI6	-	11	DI6
A7	DI8	N/A		-
A8	STGOUT0	20	-	STGOUT0/SHTOUT0

Connection connector for F160-VP		Connection connector on the Sensor Controller		
Pin No.	Signal name	Pin No.		Signal name
CN3		CN1	CN2	
A9	RUN	15	-	RUN0
A10	BUSY	17	-	BUSY0
A11	OR	18	-	OR0
A12	DO0	-	17	DO0
A13	DO2	-	19	DO2
A14	DO4	-	21	DO4
A15	DO6	-	23	DO6
A16	DO8	-	25	DO8
A17	DO9	-	26	DO9
A18	DO11	-	28	DO11
A19	DO13	-	30	DO13
A20	DO15	-	32	DO15
B1	COMIN	1	-	COMIN0
		2	-	COMIN1
		-	1	COMIN2
B2	DSA	-	3	DSA0
B3	DI1	-	6	DI1
B4	DI3	-	8	DI3
B5	DI5	-	10	DI5
B6	DI7	-	12	12
B7	DI9	N/A		-
B8	STGOUT1	21	-	STGOUT1/SHTOUT1
B9	ERROR	19	-	ERROR0
B10	GATE	-	15	GATE0
B11	COMOUT1	33	-	COMOUT0
B12	DO1	-	18	DO1
B13	DO3	-	20	DO3
B14	DO5	-	22	DO5
B15	DO7	-	24	DO7
B16	COMOUT2	34	-	COMOUT1
B17	DO10	-	27	DO10
B18	DO12	-	29	DO12
B19	DO14	-	31	DO14
B20	COMOUT3	-	33	COMOUT2
		-	34	COMOUT3

Note: COMOUT is unified in 1 system with shorting B11, B16, and B20.

6-2 Encoder Interface

Encoder interface (open corrector type) is supported only FH-1000/2000/3000/5000 series.

6-2-1 FH-1000/2000/3000/5000 Series



Precautions for Safe Use

- Check the following again before turning on the power.
Are the voltage value and polarity of the power supply that is provided to the encoder cable (ENC0 VDD/GND, ENC1 VDD/GND) correct? (5 VDC)
- Use only the cables designed specifically for the product. Use of other products may result in malfunction or damage of the product.
- Always turn OFF the power of the FH-L series Sensor Controller and peripheral devices before connecting or disconnecting a camera or cable. Connecting the cable with power supplied may result in damage of the camera or peripheral devices.
- Since cables to which bending is frequently applied is easily broken, use the robotic cable type (bending resistant cable) to prevent damages.
- Do not apply torsion stress to cables. If not, it may cause damage to cables.
- Secure the minimum bending radius of cables. If not, it may cause damage to cables.



Precautions for Correct Use

- Check the following items on the communications cables that are used in the network.
 - Are there any breaks?
 - Are there any shorts?
 - Are there any connector problems?
- When you connect the cable to the communications connectors on devices, firmly insert the communications cable connector until it locks in place.
- Do not lay the communications cables together with high-voltage lines.
- Do not lay the communications cable near devices that generate noise.
- Do not lay the communications cables in locations subject to high temperatures or high humidity.
- Do not lay the communications cables in locations subject to excessive dirt and dust or to oil mist or other contaminants.

Interface Specification

Item	Specifications
Input voltage	Input voltage: 5 VDC $\pm 5\%$, Signal level: EIA Standard, RS-422-A line driver level
Input impedance *1	120 Ω $\pm 5\%$
Differential input voltage	High-level input voltage: 0.1 V Low-level input voltage: -0.1 V
Hysteresis voltage	60 mV
Maximum response frequency *2	Phase A/B/Z: 1 MHz (When using an I/O cable, model FH-VR 1.5M)

*1. Value when the terminal resistance function is used.

*2. Use this interface as paying attention to the cable length and response frequency of the encoder used.

Cable, I/O Connector and Terminal Block

Use the following Encoder cable: FH-VR 1.5 M (1.5 m, Min. bending radius: 65 mm).

● Encoder Cable

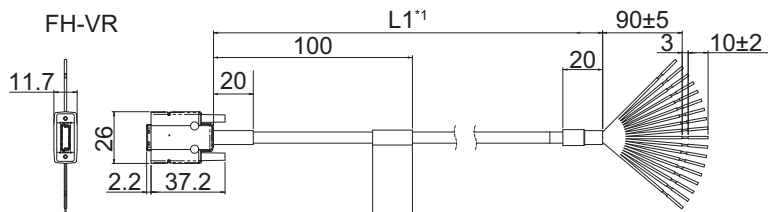

*1: Cable is available in 1.5 m.



Additional Information

We have the 2D CAD data or 3D CAD data.
You can download CAD data from www.fa.omron.co.jp.

Pin Layout

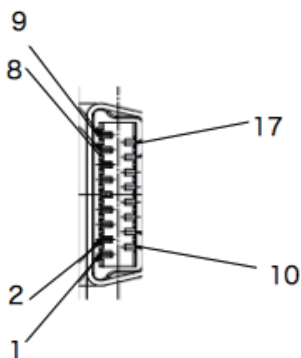

No.	Signal name	Color	Remark
1	ENC0 A+	Black	Signal CH1 Phase A (+)
2	ENC0 A-	Black/Red	Signal CH1 Phase A (-)
3	ENC0 VDD	Brown	Power CH1 power supply (5V)
4	ENC0 B+	White	Signal CH1 Phase B (+)
5	ENC0 B-	White/Red	Signal CH1 Phase B (-)
6	ENC0 GND	Blue	Power CH1 GND (0V)
7	ENC0 Z+	Orange	Signal CH1 Phase Z (+)
8	ENC0 Z-	Orange/Red	Signal CH1 Phase Z (-)
9	NC	-	-
10	ENC1 A+	Purple	Signal CH2 Phase A (+)
11	ENC1 A-	Purple/Red	Signal CH2 Phase A (-)
12	ENC1 VDD	Brown/Red	Power CH2 power supply (5V)
13	ENC1 B+	Pink	Power CH2 Phase B (+)
14	ENC1 B-	Pink/Red	Power CH2 Phase B (-)
15	ENC1 GND	Blue/Red	Power CH2 GND (0V)

No.	Signal name	Color	Remark
16	ENC1 Z+	Yellow	Power CH2 Phase Z (+)
17	ENC1 Z-	Yellow/Red	Power CH2 Phase Z (-)

Encoder Circuit Schematics

Line driver input type
CH1 (Line 0)

Line driver input type

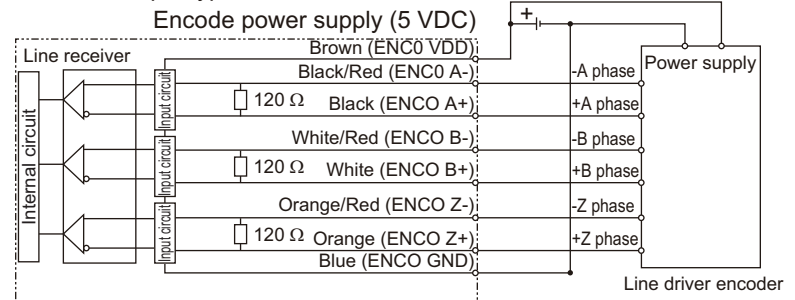

Line driver input type
CH2 (Line 1)

Line driver input type

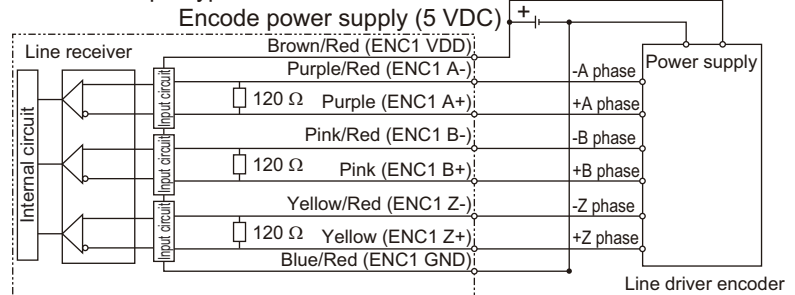

6-3 EtherCAT Interface

EtherCAT interface is supported only FH-1000/2000/3000/5000 series.

6-3-1 FH-1000/2000/3000/5000 Series



Precautions for Safe Use

- Use only the cables designed specifically for the product. Use of other products may result in malfunction or damage of the product.
- Always turn OFF the power of the FH-L series Sensor Controller and peripheral devices before connecting or disconnecting a camera or cable. Connecting the cable with power supplied may result in damage of the camera or peripheral devices.
- Since cables to which bending is frequently applied is easily broken, use the robotic cable type (bending resistant cable) to prevent damages.
- Do not apply torsion stress to cables. If not, it may cause damage to cables.
- Secure the minimum bending radius of cables. If not, it may cause damage to cables.



Precautions for Correct Use

- Check the following items on the communications cables that are used in the network.
 - Are there any breaks?
 - Are there any shorts?
 - Are there any connector problems?
- When you connect the cable to the communications connectors on devices, firmly insert the communications cable connector until it locks in place.
- Do not lay the communications cables together with high-voltage lines.
- Do not lay the communications cable near devices that generate noise.
- Do not lay the communications cables in locations subject to high temperatures or high humidity.
- Do not lay the communications cables in locations subject to excessive dirt and dust or to oil mist or other contaminants.

Cable

- Connect a straight LAN cable.
- Use an STP cable of category 5e or higher, which is double-shielded with aluminum tape and braided cord.
- The maximum cable length is 100 [m]. Some cables, however, are not guaranteed with 100 [m]. Generally, the transmission performance of conductor twisted cables become worse than that of single cables, so that 100 [m] is not guaranteed. For details, contact your cable manufacturer.

I/O Connector

- For electrical specifications, complying with IEEE 802.3 standard and use RJ45 8-pin modular connector (complying with ISO 8877) supporting category 5e or higher.
- When selecting connectors, check that it is suitable for the cable to be used. Items to be checked are conductor size, stranded or single, two pairs or four pairs, outer diameter, and so on.

Pin Layout

Pin assignment	Pin No.	Signal name	Abbr.	Signal direction
	1	Transmission data +	TD +	Output
	2	Transmission data -	TD -	Output
	3	Reception data +	RD +	Input
	4	Not used	NC	-
	5	Not used	NC	-
	6	Reception data -	RD -	Input
	7	Not used	NC	-
	8	Not used	NC	-
	Connector hood	Security ground	FG	-

Wiring

- Connect both ends of the cable shield to the connector hood.
- Apply the T568A method below.

Pin No.	Wire color	Wire color	Pin No.
1	White-Green	White-Green	1
2	Green	Green	2
3	White-Orange	White-Orange	3
4	Blue	Blue	4
5	White-Blue	White-Blue	5
6	Orange	Orange	6
7	White-Brown	White-Brown	7
8	Brown	Brown	8
Connector hood	Shielded cable	Shielded cable	Connector hood

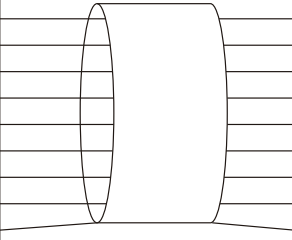

6-4 Ethernet Interface

Ethernet port of Sensor Controller is used for EtherNet/IP or Serial (Ethernet) communication. The Ethernet port can be changed depending on Sensor Controller series. Be sure to check the series you are attempting to use.



Precautions for Safe Use

- Use only the cables designed specifically for the product. Use of other products may result in malfunction or damage of the product.
- Always turn OFF the power of the FH-L series Sensor Controller and peripheral devices before connecting or disconnecting a camera or cable. Connecting the cable with power supplied may result in damage of the camera or peripheral devices.
- Since cables to which bending is frequently applied is easily broken, use the robotic cable type (bending resistant cable) to prevent damages.
- Do not apply torsion stress to cables. If not, it may cause damage to cables.
- Secure the minimum bending radius of cables. If not, it may cause damage to cables.



Precautions for Correct Use

- Check the following items on the communications cables that are used in the network.
 - Are there any breaks?
 - Are there any shorts?
 - Are there any connector problems?
- When you connect the cable to the communications connectors on devices, firmly insert the communications cable connector until it locks in place.
- Do not lay the communications cables together with high-voltage lines.
- Do not lay the communications cable near devices that generate noise.
- Do not lay the communications cables in locations subject to high temperatures or high humidity.
- Do not lay the communications cables in locations subject to excessive dirt and dust or to oil mist or other contaminants.

6-4-1 FH-1000/2000/3000/5000 Series

Ethernet port differ depending on the Sensor Controller series. Refer to the followings, and confirm the number of ports. FH-1050/3050 (Camera 2ch type); Ethernet port is 1. FH-2050/5050 (Camera 2ch type) and FH-1050-□0/2050-□0/3050-□0/5050-□0 (Camera 4ch and 8ch type): Ethernet port is 2.

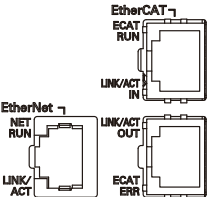
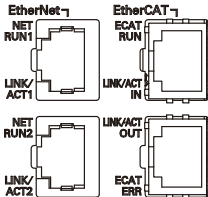
FH-1050/FH-3050	FH-1050-10/FH-1050-20/FH-3050-10/FH-3050-20 FH-2000/FH-5000 series
<p>Ethernet port and EtherNet/IP port are sharing use.</p> 	<ul style="list-style-type: none"> • Upper port: Ethernet port • Lower port: Ethernet port and EtherNet/IP port are sharing use. 

Cable

- Connect a straight or cross LAN cable.

- The transmission rate you use determines available cables and connectors.
- For 100BASE-TX or 10BASE-T, use an STP (shielded twist pair) cable with category 5 or higher.
- For 1000BASE-T, use an STP cable (double-shielded with aluminum tape and braided cord) with category 5e or higher.

I/O Connector

- For electrical specifications, complying with IEEE 802.3 standard and use RJ45 8-pin modular connector (complying with ISO 8877) supporting category 5e or higher.
- When selecting connectors, check that it is suitable for the cable to be used. Items to be checked are conductor size, stranded or single, two pairs or four pairs, outer diameter, and so on.

Pin Layout

● 10Base-T and 100Base-TX

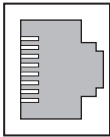
Pin assignment	Pin No.	Signal name	Abbr.	Signal direction
	1	Transmission data +	TD +	Output
	2	Transmission data -	TD -	Output
	3	Reception data +	RD +	Input
	4	Not used	-	-
	5	Not used	-	-
	6	Reception data -	RD -	Input
	7	Not used	-	-
	8	Not used	-	-

● 1000Base-T

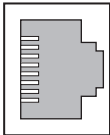
Pin assignment	Pin No.	Signal name	Abbr.	Signal direction
	1	Communication data DA +	BI_DA +	I/O
	2	Communication data DA -	DI_DA -	I/O
	3	Communication data DB +	BI_DB +	I/O
	4	Communication data DB -	BI_DC +	I/O
	5	Communication data DC +	BI_DC -	I/O
	6	Communication data DC -	BI_DB -	I/O
	7	Communication data DD +	BI_DD +	I/O
	8	Communication data DD -	BI_DD -	I/O

Wire

Describes the connection processing to connector hood of shield as the following. The connection processing is changed according to the transfer speed.

- 10 BASE-T/100 BASE-TX

Connect both ends of the cable shield to the connector hood. Or, connect only the shield of one end of the cable, switching hub side, to the connector hood.

- 1000 BASE-T
Connect both ends of the cable shield to the connector hood.

6-4-2 FH-L Series

Cable

- Connect a straight or cross LAN cable.
- The transmission rate you use determines available cables and connectors.
- For 100BASE-TX or 10BASE-T, use an STP (shielded twist pair) cable with category 5 or higher.
- For 1000BASE-T, use an STP cable (double-shielded with aluminum tape and braided cord) with category 5e or higher.

I/O Connector

- For electrical specifications, complying with IEEE 802.3 standard and use RJ45 8-pin modular connector (complying with ISO 8877) supporting category 5e or higher.
- When selecting connectors, check that it is suitable for the cable to be used. Items to be checked are conductor size, stranded or single, two pairs or four pairs, outer diameter, and so on.

Pin Layout

● 10Base-T and 100Base-TX

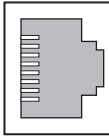
Pin assignment	Pin No.	Signal name	Abbr.	Signal direction
	1	Transmission data +	TD +	Output
	2	Transmission data -	TD -	Output
	3	Reception data +	RD +	Input
	4	Not used	-	-
	5	Not used	-	-
	6	Reception data -	RD -	Input
	7	Not used	-	-
	8	Not used	-	-

● 1000BASE-T

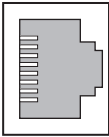
Pin assignment	Pin No.	Signal name	Abbr.	Signal direction
	1	Communication data DA +	BI_DA +	I/O
	2	Communication data DA -	DI_DA -	I/O
	3	Communication data DB +	BI_DB +	I/O
	4	Communication data DB -	BI_DC +	I/O
	5	Communication data DC +	BI_DC -	I/O
	6	Communication data DC -	BI_DB -	I/O
	7	Communication data DD +	BI_DD +	I/O
	8	Communication data DD -	BI_DD -	I/O

Wiring

Describes the connection processing to connector hood of shield as the following. The connection processing is changed according to the transfer speed.

- 10 BASE-T/100 BASE-TX
Connect both ends of the cable shield to the connector hood. Or, connect only the shield of one end of the cable, switching hub side, to the connector hood.
- 1000 BASE-T
Connect both ends of the cable shield to the connector hood.

6-5 Serial Interface

Serial interface of Sensor Controller differs by series. Refer to the correct information for the series you are using.

RS-232C interface is used in FH-1000/2000/3000/5000 and FH-L series.

6-5-1 All Series



Precautions for Safe Use

- Use only the cables designed specifically for the product. Use of other products may result in malfunction or damage of the product.
- Always turn OFF the power of the FH-L series Sensor Controller and peripheral devices before connecting or disconnecting a camera or cable. Connecting the cable with power supplied may result in damage of the camera or peripheral devices.
- Since cables to which bending is frequently applied is easily broken, use the robotic cable type (bending resistant cable) to prevent damages.
- Do not apply torsion stress to cables. If not, it may cause damage to cables.
- Secure the minimum bending radius of cables. If not, it may cause damage to cables.



Precautions for Correct Use

- Check the following items on the communications cables that are used in the network.
 - Are there any breaks?
 - Are there any shorts?
 - Are there any connector problems?
- When you connect the cable to the communications connectors on devices, firmly insert the communications cable connector until it locks in place.
- Do not lay the communications cables together with high-voltage lines.
- Do not lay the communications cable near devices that generate noise.
- Do not lay the communications cables in locations subject to high temperatures or high humidity.
- Do not lay the communications cables in locations subject to excessive dirt and dust or to oil mist or other contaminants.

Cable

- For communication cable, use a shielded twisted-pair cable.
- The maximum cable length is 15 [m].

How to Connect

- Align the connector to the socket and press it straight into place, then tighten it with the screws on both sides of the connector.

Input and output Connector

Prepare the suitable connector. Recommended connector is the following table.

Name	Manufacturer	Model
Sockets	OMRON Corporation	XM3D-0921
Hood		XM2S-0911

Pin Layout

D-Sub9 Male type connector is used in Sensor Controller.

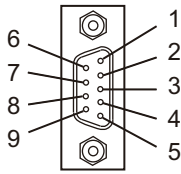
Pin assignment	Pin No.	Signal name	Description
	1	NC	Not used
	2	RD	Reception data
	3	SD	Transmission data
	4	NC	Not used
	5	GND	Signal ground
	6	NC	Not used
	7	NC	Not used
	8	NC	Not used
	9	NC	Not used

Wiring

- Bundle each cable with SG (signal ground) as a twisted pair cable. Connect the bundled SG cables with the connector on the Sensor Controller and the connector on the other device.
- Connect the communication cable shield to the RS-232C connector shell (FG) on the Sensor Controller.
- The pin numbering will differ depending on type and model of the connected external device.

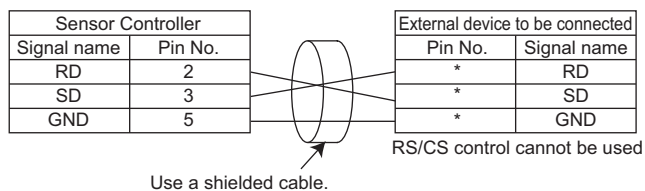



Index



Index

Symbols

0.3 Megapixels Camera: FH-SC/-SM	
Dimensions.....	3 - 21
0.3 Megapixels Camera: FZ-S/-SC	
Dimensions.....	3 - 28
0.4 Megapixels Camera: FH-SCX/-SMX	
Dimensions.....	3 - 22
1000BASE-T.....	6 - 35,6 - 36
10Base-T and 100Base-TX.....	6 - 35,6 - 36
12 Megapixels Camera: FH-SC12/-SM12	
Dimensions.....	3 - 23
12 Megapixels Camera: FH-SCX12/-SMX12	
Dimensions.....	3 - 23
20.4 Megapixels Camera: FH-SM21R/FH-SC21R	
Dimensions.....	3 - 26
2 Megapixels Camera: FH-SC02/-SM02	
Dimensions.....	3 - 22
2 Megapixels Camera: FZ-S2M/-SC2M	
Dimensions.....	3 - 28
5 Megapixels Camera: FH-SCX05/-SMX05	
Dimensions.....	3 - 23
5 Megapixels Camera: FH-SM05R/-SC05R	
Dimensions.....	3 - 25
5 Megapixels Camera: FZ-S5M2/-SC5M2	
Dimensions.....	3 - 29
5 Megapixels Camera: FZ-S5M3/-SC5M3	
Dimensions.....	3 - 26

A

Accessibility for Operation and Maintenance.....	5 - 28,5 - 29,5 - 31
ACCESS LED.....	3 - 11,3 - 17
Accessories.....	1 - 9
Ambient Temperature.....	4 - 4,4 - 5
Ambient temperature and humidity.....	5 - 28
Analog Lighting Controller.....	1 - 8
Application Producer.....	1 - 13

B

Basic System of Measurement.....	2 - 2
Bend resistant Camera Cable.....	1 - 7,3 - 37
Specification.....	3 - 37
Bend resistant Camera Cable: FZ-VSB3	
Dimensions.....	3 - 38
Bend resistant Right-angle Camera Cable.....	1 - 7,3 - 37
Specification.....	3 - 37
Bend resistant Right-angle Camera Cable: FZ-VSLB3	
Dimensions.....	3 - 38

C

Cable.....	1 - 10
Cable (FH-VPX-F160).....	6 - 25

Cable (FH-VPX-F210).....	6 - 27
Cable (FH-VPX-FZ).....	6 - 20
Cable (FH-VPX-FZL).....	6 - 23
Cable Connection Table.....	3 - 39
Cable Extension Unit.....	1 - 7
Cable Extension Units.....	3 - 43
Connection Configuration.....	3 - 46
Dimensions.....	3 - 43
Specification.....	3 - 43
Cable with Rugged type Connectors on Both Ends (M12/RJ45).....	1 - 11
Cable with Rugged type Connectors on Both Ends (RJ45/RJ45).....	1 - 10
Cable with Standard type Connectors on Both Ends (RJ45/RJ45).....	1 - 10
Calibration Plate.....	1 - 9
Camera.....	1 - 5,3 - 19
Camera Amplifier	
Dimensions.....	3 - 32
Camera Cable.....	1 - 7,3 - 36
Specification.....	3 - 36
Camera Cable: FZ-VS3	
Dimensions.....	3 - 36
Camera Cable for FH-S Camera Series.....	3 - 40
Camera Cable for FZ-S Camera Series.....	3 - 42
Camera cable mounting.....	5 - 23,5 - 24
Camera connector.....	3 - 11,3 - 17
Camera Head	
Dimensions.....	3 - 32
Camera Installation.....	5 - 22
All Series.....	5 - 22
FH-1000/2000/3000/5000 Series.....	5 - 23
FH-L Series.....	5 - 24
Camera Mounting Bracket.....	1 - 7
Camera Mount Lighting Controller.....	1 - 8
Cameras and Related.....	1 - 5
CLIPFIX 35.....	1 - 9
C-mount Lens for 1/3-inch Image Sensor (SV-V Series).....	3 - 47
Specification.....	3 - 47
C-mount Lens for 1-inch Image Sensor (VS-H1 Series).....	3 - 49
Specification.....	3 - 49
C-mount Lens for 2/3-inch Image Sensor (SV-H Series).....	3 - 48
Specification.....	3 - 48
C-mount Lens for 4/3-inch Image Sensor (VS-LLD Series)....	3 - 50
Specification.....	3 - 50
Common items related to DIN rail.....	1 - 9
Concept of Measurement Processing.....	2 - 3
Configuration.....	3 - 1
confirm the Package.....	1 - 1
Connection configuration using the maximum length of Camera Cables.....	3 - 46

- Connection of Terminal Block of FH-1000/2000/3000/5000 Series..... 5 - 6
- Connection of Terminal Block of FH-L Series..... 5 - 11
- Connection Structure (FH-VPX-F160)..... 6 - 25
- Connection Structure (FH-VPX-F210)..... 6 - 27
- Connection Structure (FH-VPX-FZ)..... 6 - 19
- Connection Structure (FH-VPX-FZL)..... 6 - 22
- Connector-Terminal Block Conversion Units, General-purpose devices..... 1 - 10
- ## D
- Digital CCD Camera: FZ-S Camera Series..... 3 - 27
- Dimensions..... 3 - 27
- Specification..... 3 - 27
- Digital CCD Cameras..... 1 - 6
- Digital CMOS Camera..... 3 - 24
- Dimensions..... 3 - 25
- Specification..... 3 - 24
- Digital CMOS Cameras..... 1 - 6
- DIN 35 mm rail..... 1 - 9
- DIN rail mounting bracket..... 1 - 9
- DVI-Analog Conversion Cable for Touch Panel Monitor.. 1 - 8
- DVI-Analog Conversion Cable for Touch Panel Monitor: FH-VMDA
- Dimensions..... 3 - 86
- DVI-I connector..... 3 - 10
- DVI-I -RGB Conversion Connector..... 1 - 8
- DVI-I -RGB Conversion Connector: FH-VMRGB
- Dimensions..... 3 - 90
- ## E
- ECAT ERROR..... 3 - 12
- ECAT RUN..... 3 - 12
- Encoder Cable..... 1 - 10, 6 - 30
- Encoder Circuit Schematics..... 6 - 31
- Encoder connector..... 3 - 11
- Encoder Interface..... 6 - 29
- FH-1000/2000/3000/5000 Series..... 6 - 29
- Cable, I/O Connector and Terminal Block..... 6 - 30
- Interface Specification..... 6 - 29
- Pin Layout..... 6 - 30
- End plate..... 1 - 9
- ERROR LED..... 3 - 11, 3 - 17
- EtherCAT address setup volume..... 3 - 10
- EtherCAT communication connector (IN)..... 3 - 11
- EtherCAT communication connector (OUT)..... 3 - 11
- EtherCAT Connection for FH Series..... 2 - 4
- EtherCAT ERR LED..... 3 - 11
- EtherCAT Interface..... 6 - 32
- FH-1000/2000/3000/5000 Series..... 6 - 32
- Cable..... 6 - 32
- I/O Connector..... 6 - 32
- Pin Layout..... 6 - 33
- Wring..... 6 - 33
- EtherCAT junction slaves..... 1 - 9
- EtherCAT LINK/ACT IN LED..... 3 - 11
- EtherCAT LINK/ACT OUT LED..... 3 - 11
- EtherCAT RUN LED..... 3 - 11
- EtherCAT status indicator LED..... 3 - 12
- Ethernet connector..... 3 - 10, 3 - 17
- Ethernet Interface..... 6 - 34
- FH-1000/2000/3000/5000 Series..... 6 - 34
- Cable..... 6 - 34
- I/O Connector..... 6 - 35
- Pin Layout..... 6 - 35
- Wire..... 6 - 35
- FH-L Series..... 6 - 36
- Cable..... 6 - 36
- I/O Connector..... 6 - 36
- Pin Layout..... 6 - 36
- Wiring..... 6 - 37
- Ethernet LINK/ACT1 LED..... 3 - 12
- Ethernet LINK/ACT2 LED..... 3 - 12
- Ethernet LINK/ACT LED..... 3 - 18
- Ethernet NET RUN1 LED..... 3 - 12
- Ethernet NET RUN2 LED..... 3 - 12
- Ethernet NET RUN LED..... 3 - 18
- Extension Tubes..... 3 - 65
- Specification..... 3 - 65
- External Lighting..... 1 - 8
- ## F
- FAE-5002..... 1 - 11
- FAE-5004..... 1 - 11
- Ferrite core for camera cable..... 1 - 2, 1 - 3
- FH-1□□□/FH-2□□□/ FH-3□□□/ FH-5□□□ Series.... 1 - 2
- FH-1□□□-10/ FH-2□□□-10/ FH-3□□□-10/ FH-5□□□-10 Series..... 1 - 2
- FH-1□□□-20/ FH-2□□□-20/ FH-3□□□-20/ FH-5□□□-20 Series..... 1 - 3
- FH-1000/ FH-2000/ FH-3000/ FH-5000 Series
- Component Names and Functions..... 3 - 10
- Dimensions..... 3 - 13
- FH-3000/ FH-1000
- Specification..... 3 - 6
- FH-5000/ FH-2000
- Specification..... 3 - 3
- FH-ADF/M42-10..... 1 - 7
- FH-L□□□-10 Series..... 1 - 3
- FH-L□□□ Series..... 1 - 3
- FH-L Series
- Component Names and Functions..... 3 - 16
- Dimensions..... 3 - 18
- Specification..... 3 - 14
- FH-MT12..... 1 - 8
- FH-SC..... 1 - 5
- FH-SC02..... 1 - 5
- FH-SC04..... 1 - 5
- FH-SC05R..... 1 - 6
- FH-SC12..... 1 - 5
- FH-SC21R..... 1 - 6
- FH-SCX..... 1 - 5
- FH-SCX05..... 1 - 5
- FH-SCX12..... 1 - 5
- FH-SM..... 1 - 5
- FH-SM02..... 1 - 5

FH-SM04.....	1 - 5
FH-SM05R.....	1 - 6
FH-SM12.....	1 - 5
FH-SM12-XLC.....	1 - 7
FH-SM21R.....	1 - 6
FH-SMX.....	1 - 5
FH-SMX05.....	1 - 5
FH-SMX12.....	1 - 5
FH-SM-XLC.....	1 - 7
FH-VM DA □M.....	1 - 8
FH-VM RGB.....	1 - 8
FH-VPX-F160.....	6 - 25
FH-VPX-F210.....	6 - 26
FH-VPX-FZ.....	6 - 19
FH-VPX-FZL.....	6 - 21
FH-VR 1.5M.....	1 - 10
FH-VUAB □M.....	1 - 8
FH-XCN.....	1 - 2,1 - 3
FH-XCN-L.....	1 - 3,1 - 4
FH-XDM-L.....	1 - 9
Flat Camera: FZ-SF/SFC	
Dimensions.....	3 - 32
F-LINK-E 0.5mm x 4P.....	1 - 11
Flow of Use Procedure.....	2 - 8
FL Series.....	1 - 8
FL-TCC Series.....	1 - 8
FLV-ATC Series.....	1 - 8
FLV Series.....	1 - 8
FLV-TCC Series.....	1 - 8
FQ-XF1.....	1 - 7
FQ-XL.....	1 - 7
FQ-XL2.....	1 - 7
FZ_FH Remote Operation Tool.....	5 - 26
FZD-CAL.....	1 - 9
FZ-DU.....	1 - 9
FZ-M08.....	1 - 8
FZ-MEM2G.....	1 - 9
FZ-MEM8G.....	1 - 9
FZ-S.....	1 - 6
FZ-S2M.....	1 - 6
FZ-S2M-XLC.....	1 - 7
FZ-S5M3.....	1 - 6
FZ-SC.....	1 - 6
FZ-SC2M.....	1 - 6
FZ-SC5M3.....	1 - 6
FZ-SF.....	1 - 6
FZ-SFC.....	1 - 6
FZ-SH.....	1 - 6
FZ-SHC.....	1 - 6
FZ-SH-XLC.....	1 - 7
FZ-SP.....	1 - 6
FZ-SPC.....	1 - 6
FZ-SQ010F.....	1 - 6
FZ-SQ050F.....	1 - 6
FZ-SQ100F.....	1 - 6
FZ-SQ100N.....	1 - 6
FZ-S-XLC.....	1 - 7
FZ-V3 □M.....	1 - 7
FZ-VM.....	1 - 8
FZ-VS4 15M.....	1 - 7
FZ-VSB3 □M.....	1 - 7
FZ-VSJ.....	1 - 7
FZ-VSL3 □M.....	1 - 7
FZ-VSL4 15M.....	1 - 7
FZ-VSLB3 □M.....	1 - 7
G	
General Compliance Information and Instructions for EU.....	1 - 2-1 - 4
GX-JC03.....	1 - 9
H	
Handling and Installation Environment.....	4 - 1
All Series.....	4 - 2
FH-1000/2000/3000 Series.....	4 - 4
FH-L Series.....	4 - 5
Handling a SD memory card.....	4 - 4
Handling of Sensor Controller.....	4 - 2,4 - 3
Handling SD memory card.....	4 - 5
High-resolution Telecentric Lens for C-mount Lens for 1.1- inch Image Sensor (VS-TEV Series).....	3 - 64
Specification.....	3 - 64
High-resolution Telecentric Lens for C-mount Lens for 2/3- inch Image Sensor (VS-TCH Series).....	3 - 62
Specification.....	3 - 62
High-speed Digital CCD Camera: FZ-SH Camera Series.....	
.....	3 - 29
Dimensions.....	3 - 30
Specification.....	3 - 29
High-speed Digital CCD Cameras.....	1 - 6
High-speed digital CMOS Camera (FH-S camera series).....	
.....	3 - 19
Dimensions.....	3 - 21
Specification.....	3 - 19
High-speed Digital CMOS Cameras.....	1 - 5
HMC-SD291.....	1 - 9
HMC-SD491.....	1 - 9
How-to View the Optical Chart.....	3 - 66
I	
I/O (Parallel) connector (control lines, data lines).....	
.....	3 - 10,3 - 17
I/O Interface.....	6 - 1
Encoder Interface.....	6 - 29
EtherCAT Interface.....	6 - 32
Ethernet Interface.....	6 - 34
Parallel Interface.....	6 - 2
IETP-SB.....	1 - 11
Industrial Switching Hubs for EtherNet/IP and Ethernet..	1 - 9
Insert/Remove SD Memory Card or USB memory.....	5 - 25
Common in all series.....	5 - 25
Installation and Storage Sites.....	4 - 3
Installation Environment.....	4 - 2
Installation in a Control Panel.....	5 - 27,5 - 30,5 - 32
All Series.....	5 - 27
FH-1000/2000/3000/5000 Series.....	5 - 29

- FH-L Series..... 5 - 31
 Instruction Installation Manual for FH-L series..... 1 - 3,1 - 4
 Instruction Installation Manual for FH series..... 1 - 2,1 - 3
 Instruction sheet..... 1 - 2-1 - 4
 Intelligent Compact Digital CMOS Camera: FZ-S camera Series..... 3 - 33
 Dimensions..... 3 - 34
 Specification..... 3 - 33
 Intelligent Compact Digital CMOS Cameras..... 1 - 6
 Internal Specifications for Parallel Interface..... 6 - 9,6 - 17
- ## K
- KETH-PSB-OMR..... 1 - 11
 KETH-SB..... 1 - 11
- ## L
- L/A IN..... 3 - 12
 L/A OUT..... 3 - 12
 LCD and Cable..... 3 - 88
 Component Names and Functions..... 3 - 89
 Dimensions..... 3 - 90
 Wire..... 3 - 89
 LCD Monitor
 Dimensions..... 3 - 90
 Specification..... 3 - 88
 LCD Monitor 8.4 inches for Box-type Controllers..... 1 - 8
 LCD Monitor and Cable..... 1 - 8
 LCD Monitor Cable..... 1 - 8
 Specification..... 3 - 88
 LED indicator lamp..... 3 - 83
 LED indicator lamp (for power)..... 3 - 89
 LED indicator lamp (for SYNC)..... 3 - 89
 Lens..... 3 - 47
 Lenses for Small Camera (FZ-LES Series)..... 3 - 51
 Specification..... 3 - 51
 Lighting..... 1 - 8
 Lighting Controller..... 1 - 8
 For FL-Series..... 1 - 8
 For FLV-Series..... 1 - 8
 Long-distance Camera Cable..... 1 - 7,3 - 38
 Specification..... 3 - 38
 Long-distance Camera Cable: FZ-VS4
 Dimensions..... 3 - 39
 Long-distance Right-angle Camera Cable..... 1 - 7,3 - 38
 Specification..... 3 - 38
 Long-distance Right-angle Camera Cable: FZ-VSL4
 Dimensions..... 3 - 39
- ## M
- M42 - F Mount Conversion Adapter..... 1 - 7
 M42-mount Lens for Large Image Sensor (VS-L/M42-10 Series)..... 3 - 51
 Specification..... 3 - 51
 Maintenance..... 4 - 3
 Maximum Extension Length Using Cable Extension Units FZ-VSJ..... 3 - 44
- Meaning of Optical Chart..... 3 - 66
 Megapixels Camera: FH-SC04/-SM04
 Dimensions..... 3 - 22
 Membership registration..... 1 - 2-1 - 4
 Monitor..... 1 - 7
 Monitor Cable: FZ-VM
 Dimensions..... 3 - 90
 Monitor connector..... 3 - 17
 Monitor connector (analog RGB)..... 3 - 83
 Mounting Base for FH-S□, FZ-S□5M□, FH-S□X05, FH-S□02, FH-S□04, FH-S□X12, FH-S□21R..... 1 - 7
 Mounting Base for FH-S□12..... 1 - 7
 Mounting Base for FZ-S□, FH-S□05R, FH-S□X..... 1 - 7
 Mounting Base for FZ-S□2M..... 1 - 7
 Mounting Base for FZ-SH□2M..... 1 - 7
 Mounting Bracket for Intelligent Compact Digital Camera..... 1 - 7
 Mounting of Ferrite core..... 5 - 23
 Mounting of FH-1000/2000/3000/5000 Series..... 5 - 9
 Mounting of FH-L Series..... 5 - 13
 Mounting the DIN rail..... 5 - 15,5 - 34
 Mouse..... 1 - 9
 MPS588..... 1 - 11
 MPS588-C..... 1 - 11
- ## N
- Narrow view: FZ-SQ010F
 Dimensions..... 3 - 34
 NETSTAR-C5E SAB 0.5 x 4P CP..... 1 - 11
 NS 35/15 PERF..... 1 - 9
 NS 35/7.5 PERF..... 1 - 9
- ## O
- Optical Chart..... 3 - 67
 Normal Lenses..... 3 - 67
 Vibration/Shock-resistance Lens..... 3 - 73
 Orientation of Product..... 4 - 4,4 - 5
 OSD Menu button..... 3 - 83
 Other (Parallel Converter Cable)..... 6 - 18
 FH-VPX-F160..... 6 - 25
 FH-VPX-F210..... 6 - 26
 FH-VPX-FZ..... 6 - 19
 FH-VPX-FZL..... 6 - 21
 Overview of FH series..... 2 - 1
 Overview of System..... 2 - 2
- ## P
- Parallel I/O Cable..... 1 - 10
 Parallel I/O Cable for Connector-terminal Conversion Unit..... 1 - 10
 Parallel Interface..... 6 - 2
 All Series..... 6 - 2
 Cable, I/O connector and Terminal Block..... 6 - 5,6 - 14
 FH-1000/2000/3000/5000 Series..... 6 - 3
 Interface Specification..... 6 - 3
 Pin Layout..... 6 - 6
 FH-L Series..... 6 - 12

Interface Specification.....	6 - 12
Pin Layout.....	6 - 15
Other (Parallel Converter Cable).....	6 - 18
FH-VPX-F160.....	6 - 25
FH-VPX-F210.....	6 - 26
FH-VPX-FZ.....	6 - 19
FH-VPX-FZL.....	6 - 21
Pen-shaped Camera: FZ-SP/-SPC	
Dimensions.....	3 - 32
Pin Layout (FH-VPX-F160).....	6 - 25
PIN Layout (FH-VPX-F210).....	6 - 27
Pin Layout (FH-VPX-FZ).....	6 - 20
Pin Layout (FH-VPX-FZL).....	6 - 23
PNET/B.....	1 - 11
Polarizing Filter Attachment for Intelligent Compact Digital Camera.....	1 - 7
POWER LED.....	3 - 11
Power supply terminal.....	3 - 83,3 - 89
Power supply terminal connector.....	3 - 11,3 - 17
Precise Mounting Brackets for Intelligent Compact Digital Camera.....	1 - 7
PWR LED.....	3 - 17

R

Recommended EtherCAT Communications Cables.....	1 - 10
Recommended EtherNet/IP Communications Cables.....	1 - 10
Recommended Power Source for FH-L Series.....	5 - 12
Recommended Power Source of FH-1000/2000/3000/5000 Series.....	5 - 7
Right-angle Camera Cable.....	1 - 7,3 - 36
Specification.....	3 - 36
Right-angle Camera Cable: FZ-VSL3	
Dimensions.....	3 - 37
RS-232C Cable for Touch Panel Monitor.....	1 - 8
RS-232C Cable for Touch Panel Monitor: XW2Z-□□□PP-1	
Dimensions.....	3 - 86
RS-232C connector.....	3 - 10,3 - 17
Rugged type Cable with Connectors on Both Ends (M12 L/RJ45).....	1 - 11
RUN LED.....	3 - 11,3 - 17

S

SD BUSY LED.....	3 - 11,3 - 17
SD card.....	1 - 9
SD memory card installation connector.....	3 - 10,3 - 17
SD POWER LED.....	3 - 11
SD PWR LED.....	3 - 17
Sensor Controller.....	3 - 3
Sensor Controller Installation.....	5 - 5
All Series.....	5 - 5
FH-1000/2000/3000/5000 Series.....	5 - 5
FH-L Series.....	5 - 11
Serial Interface.....	6 - 38
All Series.....	6 - 38
Cable.....	6 - 38
How to Connect.....	6 - 38
Input and output Connector.....	6 - 38
Pin Layout.....	6 - 39

Wiring.....	6 - 39
Setup and Wiring.....	5 - 1
Setup Touch Panel Monitor or Monitor.....	5 - 20
All Series.....	5 - 20
FH-1000/2000/3000/5000 Series.....	5 - 20
FH-L Series.....	5 - 20
Simulation Software.....	5 - 26
Small Digital CCD Cameras.....	1 - 6
Small Digital CCD Cameras: FZ-S Camera Series.....	3 - 30
Dimensions.....	3 - 32
Specification.....	3 - 30
Software.....	1 - 12
Sold Separately.....	1 - 5
Standard view: FZ-SQ050F	
Dimensions.....	3 - 34
Sysmac Studio.....	1 - 12,3 - 91
Sysmac Studio FH Tool.....	5 - 26
System Configuration.....	2 - 6

T

Touch Panel Monitor.....	3 - 82
Component Names and Functions.....	3 - 83
Dimensions.....	3 - 86
Specification.....	3 - 82
Touch Panel Monitor 12.1 inches.....	1 - 8
Touch Panel Monitor and Cable.....	3 - 82
Connection Example.....	3 - 84
Dimensions.....	3 - 86
RS-232C Connection (Cable Length Up to 10 m).....	3 - 85
USB Connection (Cable Length Up to 5 m).....	3 - 84
Wiring.....	3 - 85
Touch Panel Monitor and Cables.....	1 - 8
Touch Panel Monitor Cable.....	3 - 84
Specification.....	3 - 84
Touch Panel Monitor - FH-MT12.....	3 - 82
Touch pen.....	3 - 83
Touch pen holder.....	3 - 83

U

USB/Monitor Switcher.....	1 - 9
USB2.0 connector.....	3 - 17
USB3.0 connector.....	3 - 17
USB Cable for Touch Panel Monitor.....	1 - 8
USB Cable for Touch Panel Monitor: FH-VUAB	
Dimensions.....	3 - 87
USB connector.....	3 - 10
USB Memory.....	1 - 9
USB retaining bracket.....	3 - 83
Use by Connecting Software.....	5 - 26

V

VESA mounting hole.....	3 - 83,3 - 89
Vibration and Shock.....	5 - 28
Vibration and Shock Resistant C-mount Lens for 1-inch Image Sensor (VS-MCH1 Series).....	3 - 57
Specification.....	3 - 57

Vibration and Shock Resistant C-mount Lens for 1-inch Image Sensor (VS-MCH Series).....	3 - 54
Specification.....	3 - 55
Vibration and Shock Resistant C-mount Lens for 2/3-inch Image Sensor (VS-MCA Series).....	3 - 52
Specification.....	3 - 52
Vibration and Shock Resistant M42-mount Lens for 1.8-inch Image Sensor (VS-MCL/M42-10 Series).....	3 - 60
Specification.....	3 - 60
Video input (RGB).....	3 - 89

W

W4S1-03B.....	1 - 9
W4S1-05B.....	1 - 9
W4S1-05C.....	1 - 9
When turning ON and OFF.....	5 - 2
All Series.....	5 - 2
FH-1000/2000/3000/5000 Series.....	5 - 3
FH-L Series.....	5 - 3
Wide View - Long-distance: FZ-SQ100F	
Dimensions.....	3 - 34
Wide View - Short-distance: FZ-SQ100N	
Dimensions.....	3 - 34

X

XS5W-T421-□MC-K.....	1 - 11
XS5W-T421-□MD-K.....	1 - 10
XS5W-T422-□MC-K.....	1 - 11
XS6G-T421-1.....	1 - 11
XS6W-6LSZH8SS□CM-Y.....	1 - 10
XW2R-□34GD-T.....	1 - 10
XW2Z-□□□EE.....	1 - 10
XW2Z-□□□PP-1.....	1 - 8
XW2Z-S013-□.....	1 - 10, 6 - 5, 6 - 14

OMRON Corporation Industrial Automation Company
Kyoto, JAPAN

Contact: www.ia.omron.com

Regional Headquarters

OMRON EUROPE B.V.

Wegalaan 67-69, 2132 JD Hoofddorp
The Netherlands
Tel: (31)2356-81-300/Fax: (31)2356-81-388

OMRON ELECTRONICS LLC

2895 Greenspoint Parkway, Suite 200
Hoffman Estates, IL 60169 U.S.A.
Tel: (1) 847-843-7900/Fax: (1) 847-843-7787

OMRON ASIA PACIFIC PTE. LTD.

No. 438A Alexandra Road # 05-05/08 (Lobby 2),
Alexandra Technopark,
Singapore 119967
Tel: (65) 6835-3011/Fax: (65) 6835-2711

OMRON (CHINA) CO., LTD.

Room 2211, Bank of China Tower,
200 Yin Cheng Zhong Road,
PuDong New Area, Shanghai, 200120, China
Tel: (86) 21-5037-2222/Fax: (86) 21-5037-2200

Authorized Distributor:

© OMRON Corporation 2018-2019 All Rights Reserved.
In the interest of product improvement,
specifications are subject to change without notice.

Cat. No. Z366-E1-08

1119